

STATE OF MAINE DEPARTMENT OF TRANSPORTATION



KINGFIELD FRANKLIN COUNTY

ROUTE 16\27

PROJECT NO. STP-1824(500)

PROJECT LENGTH : 2.27 MILES

PLAN LEGEND

Town, County, State	Centerline-Existing	Centerline-Proposed
Property Lines	Travelway-Existing	Travelway-Proposed
R/W Lines-Existing	Railroad	
R/W Lines-Proposed	Catch Basins	Existing Proposed
Culvert-Existing	Manholes	Existing Proposed
Culvert Proposed	Proposed Underdrain	
Curbing	Proposed Ditch	
Type 1	Existing Ditch	
Type 3	Utility Poles	Existing Proposed
Type 5	Fire Hydrants	Existing Proposed
Outline of Bodies of Water	Existing Water Line	
Ledge	Existing San. Sewer	
Buildings	Existing San. Sewer Manhole	
Trees	Guardrail-Existing	
Tree Line	Guardrail-Proposed	
Clearing Limit Line	Guardrail-Cable, Other	

INDEX OF SHEETS

Description	Sheet No.
Title Sheet	1
Typical Sections	X
Estimated Quantities	X
Drainage Sheet	X
Construction Notes	X
Plan / Profile	X
Geometric Curb Layout	X
Cross - Sections	X
Right of Way Map	X

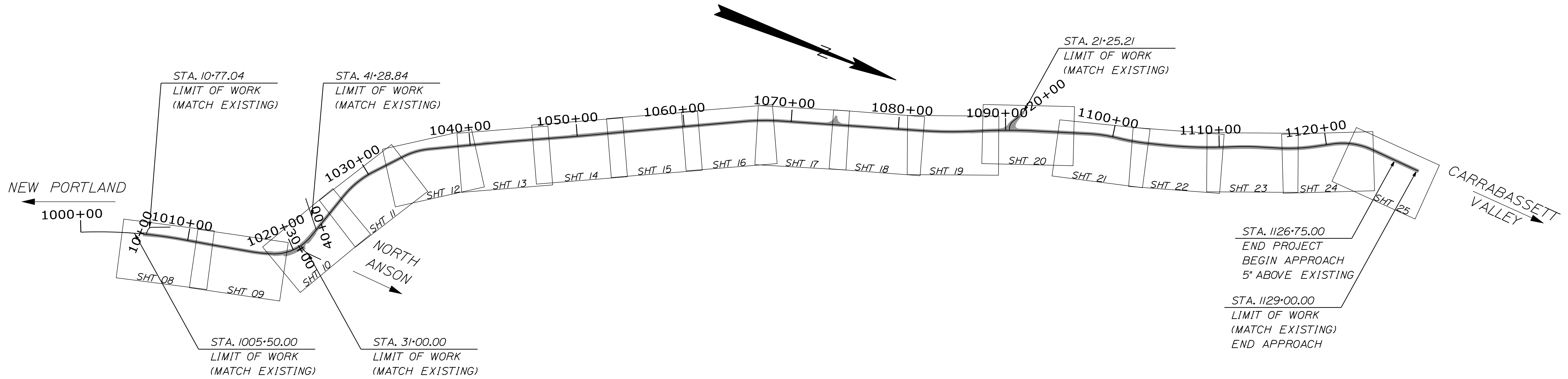

TRAFFIC DATA

Current (2018) AADT	5640
Future (2038) AADT	6770
DHV - % of AADT	11%
Design Hour Volume	858
% Heavy Trucks (AADT)	8%
% Heavy Trucks (DHV)	8%
Directional Distribution (DHV)	56%
18 kip Equivalent P 2.0	876
18 kip Equivalent P 2.5	834
Design Speed (mph)	25, 30, 45 MPH
Corridor Priority	2

LAYOUT SCALE

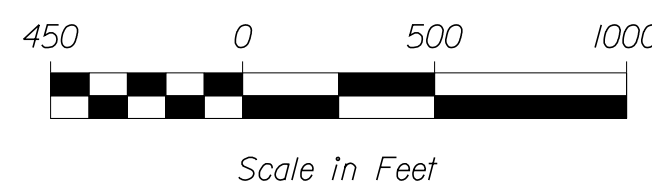

PROJECT LOCATION:

Beginning at the southern intersection of High Street and extending northerly 2.27 miles to 0.74 of a mile northerly of Tufts Road.

PROGRAM AREA:

HIGHWAY PROGRAM

SCOPE OF WORK:

Highway Rehabilitation Including Widening, Drainage, Intersection and Sidewalk Improvements

STATE OF MAINE	APPROVED	DATE
DEPARTMENT OF TRANSPORTATION	COMMISSIONER:	CHIEF ENGINEER:

SIGNATURE	P.E. NUMBER	DATE
-----------	-------------	------

PROGRAM	PROJECT MANAGER	DESIGNER	CONSULTANT	PROJECT RESIDENT	CONTRACTOR	PROJECT COMPLETION DATE
---------	-----------------	----------	------------	------------------	------------	-------------------------

18245.00 STP-1824(500)
KINGFIELD
ROUTE 16\27
TITLE SHEET

SHEET NUMBER

1

OF 175

Date: \$date\$

Username:

Division: HIGHWAY

Filename: ... \ustn\Highway\001_Title.dgn

SUPERELEVATION TABLE

LT. SHOULDER	LT. TRAVELWAY	STATION	RT. TRAVELWAY	RT. SHOULDER

LT. SHOULDER	LT. TRAVELWAY	STATION	RT. TRAVELWAY	RT. SHOULDER

NOTE:

1. THE PAVEMENT, BASE AND SUBBASE DEPTHS AS SHOWN ON THE PLANS ARE INTENDED TO BE NOMINAL.
2. WHEN SUPERELEVATION EXCEEDS THE SLOPE OF THE LOW SIDE SHOULDER, THE LOW SIDE SHOULDER SHALL HAVE THE SAME SLOPE AS THE TRAVELWAY.
3. CROWNS FOR BOTH NORMAL AND SUPERELEVATION SECTIONS FOR ALL COURSES OF SUBBASE AND PAVEMENT SHALL BE STRAIGHT.
4. THE ALGEBRAIC DIFFERENCE BETWEEN THE SHOULDER AND TRAVELWAY CROSS SLOPES "ROLLOVER" SHALL NOT EXCEED 8%. REFER TO THE SUPERELEVATION TABLE FOR SHOULDER CROSS SLOPES.
5. THE STATIONING SHOWN UNDER EACH TYPICAL IS APPROXIMATE.

KINGFIELD
ROUTE 16\27

TYPICAL SECTIONS

SHEET NUMBER

2

OF 175

STATE OF MAINE DEPARTMENT OF TRANSPORTATION STP-1824(500)	PROJ. MANAGER \$PROJMANAGER\$ DESIGN-DETAILED \$DESIGNER1\$ CHECKED-REVIEWED \$CHECKER1\$ DESIGN-DETAILED2 \$DESIGNER2\$ DESIGN-DETAILED3 \$DESIGNER3\$ REVISIONS 1 REVISIONS 2 REVISIONS 3 REVISIONS 4 FIELD CHANGES \$FIELDCHANGES\$	BY \$BY\$ DESIGNER1 \$DESIGNER1\$ DESIGNER2 \$DESIGNER2\$ DESIGNER3 \$DESIGNER3\$ REVISION1 \$REVISION1\$ REVISION2 \$REVISION2\$ REVISION3 \$REVISION3\$ REVISION4 \$REVISION4\$	DATE \$DATE\$ PROJDATE1 \$PROJDATE1\$ PROJDATE2 \$PROJDATE2\$ PROJDATE3 \$PROJDATE3\$ REVISION1 \$REVISION1\$ REVISION2 \$REVISION2\$ REVISION3 \$REVISION3\$ REVISION4 \$REVISION4\$	SIGNATURE P.E. NUMBER DATE
---	---	--	--	----------------------------------

PIN PIN 18245.00	HIGHWAY PLANS
---------------------	---------------

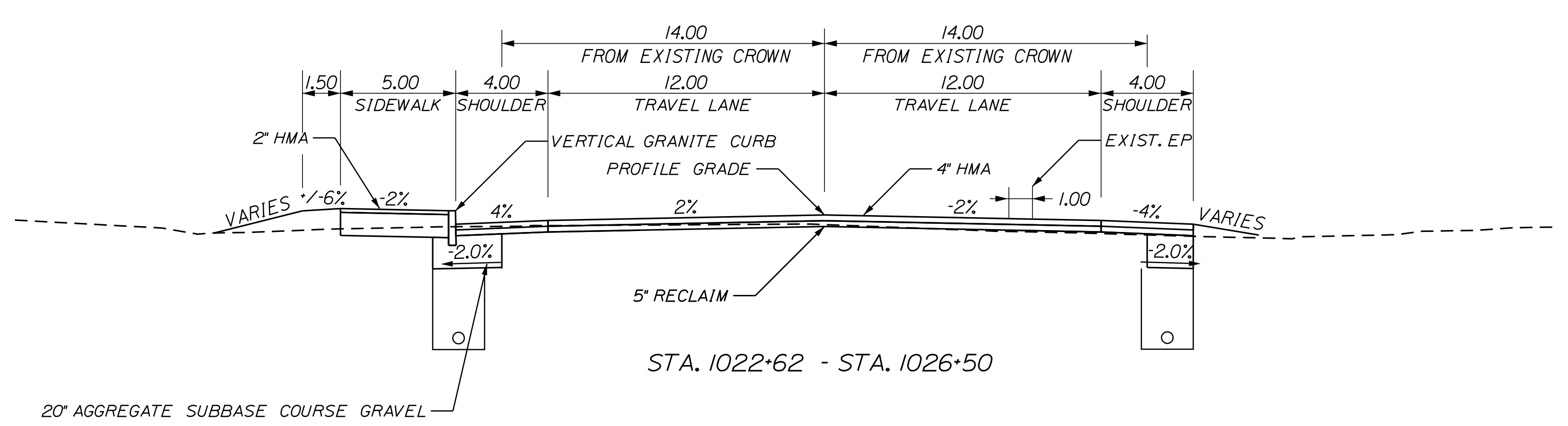
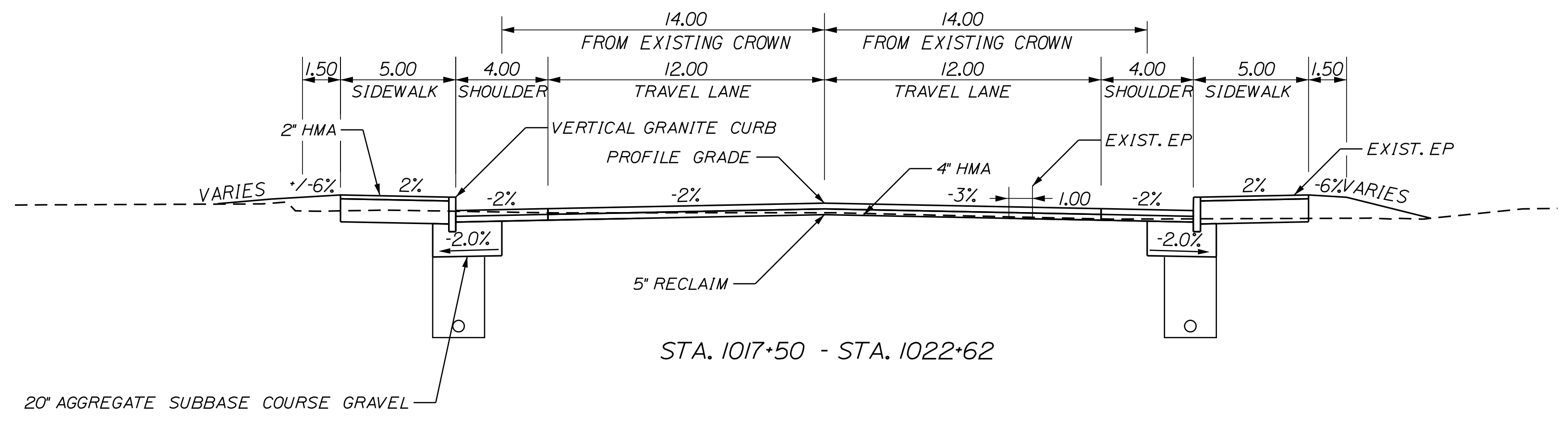
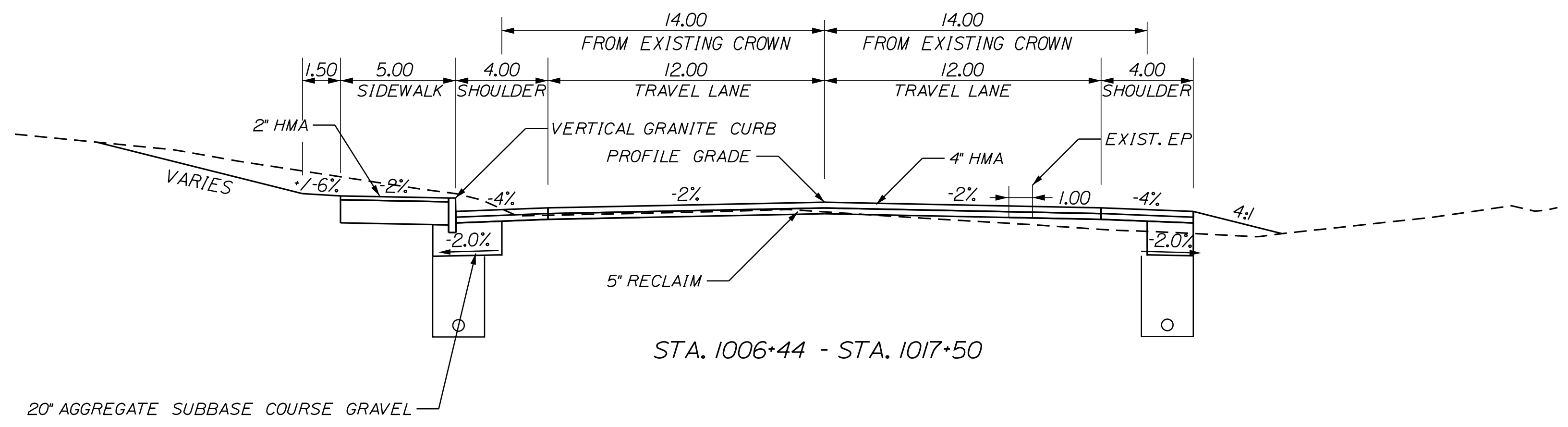

STATE OF MAINE
DEPARTMENT OF TRANSPORTATION
STP-1824(500)
PIN
PIN 18245.00
HIGHWAY PLANS

PROJ. MANAGER	DESIGN-DETAILED	CHECKED-REVIEWED	DESIGN-DETAILED	REVISIONS 1	REVISIONS 2	REVISIONS 3	REVISIONS 4	FIELD CHANGES	PROJ. MANAGER	DESIGNER	CHECKER	DESIGNER	REVISOR 1	REVISOR 2	REVISOR 3	REVISOR 4	FIELD CHANGES	DATE	BY	DATE	SIGNATURE	P.E. NUMBER	DATE

KINGFIELD
ROUTE 16\27
TYPICAL SECTIONS

SHEET NUMBER
3
OF 175

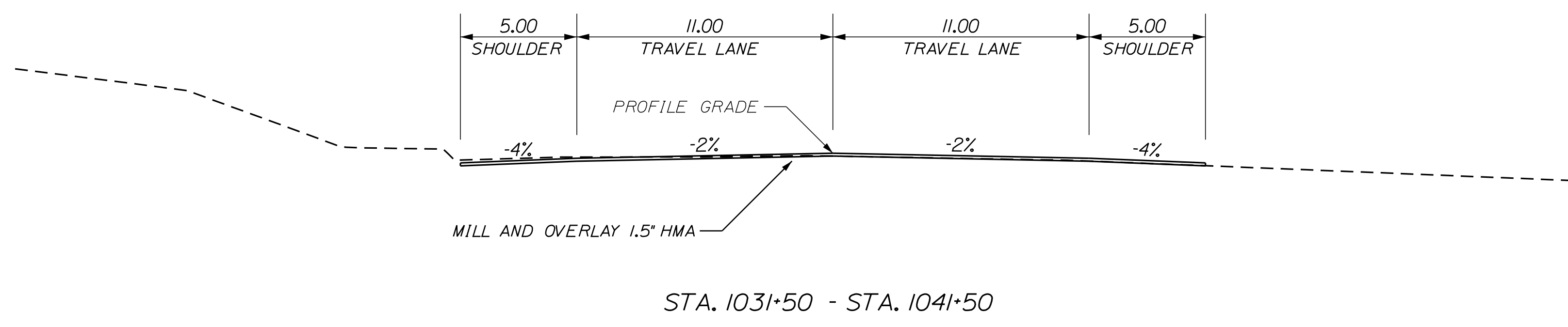
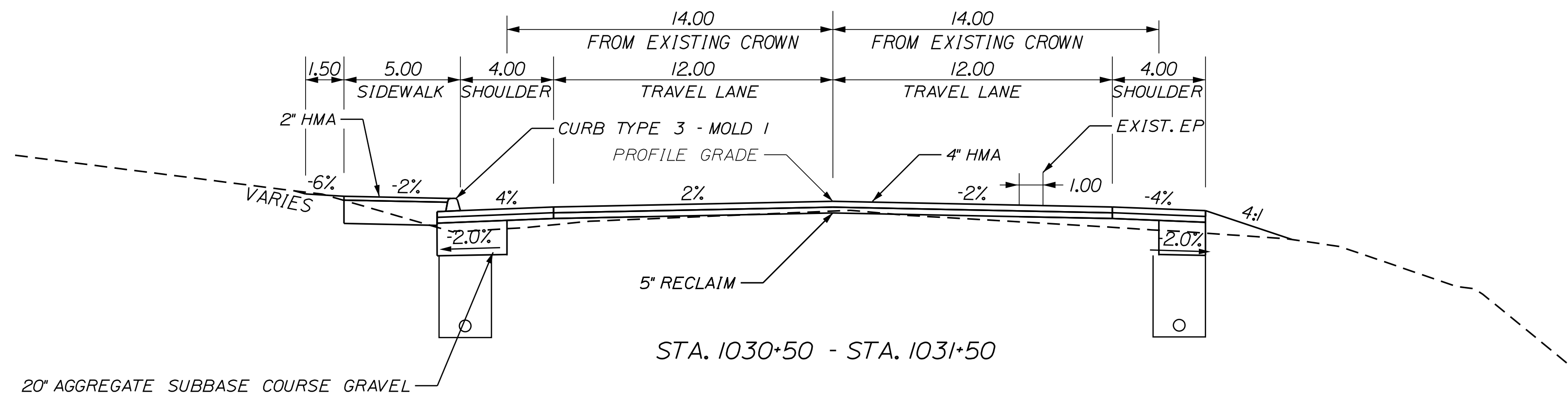
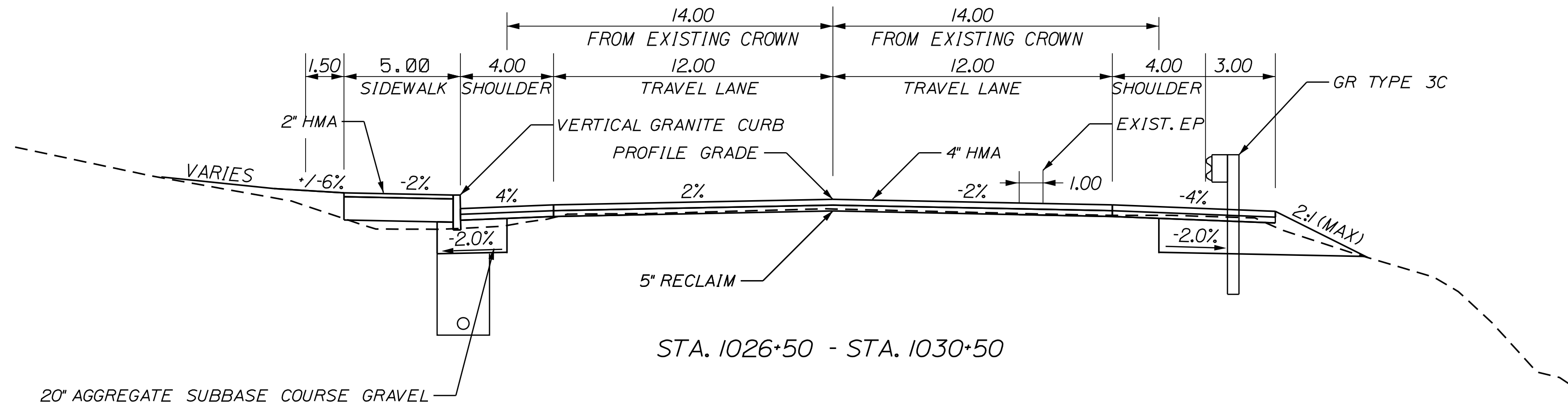

STATE OF MAINE DEPARTMENT OF TRANSPORTATION		STP-1824(500)		PIN PIN 18245.00		HIGHWAY PLANS	
KINGFIELD ROUTE 16\27		TYPICAL SECTIONS		SHEET NUMBER		4	
OF 175		DATE		BY		SIGNATURE	
PROJ. MANAGER		DESIGNER		CHECKED		DATE	
DESIGNED		DESIGNED		DESIGNED		DATE	
REVISIONS 1		REVISIONS 2		REVISIONS 3		REVISIONS 4	
FIELD CHANGES		REVISIONS		DATE		P.E. NUMBER	

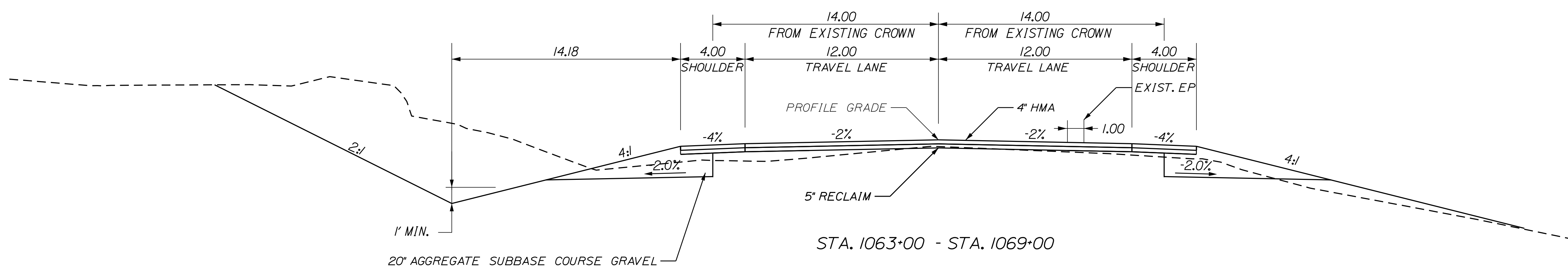
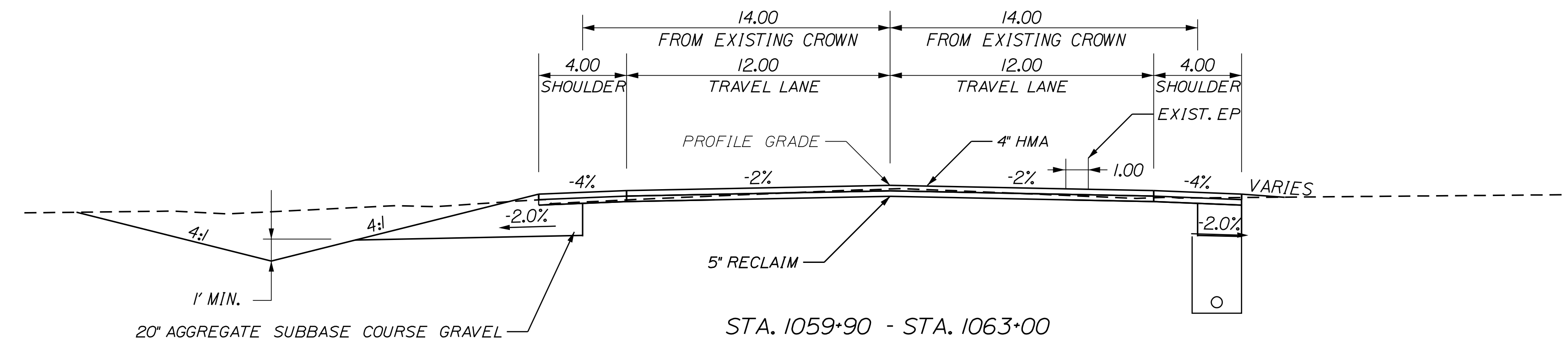
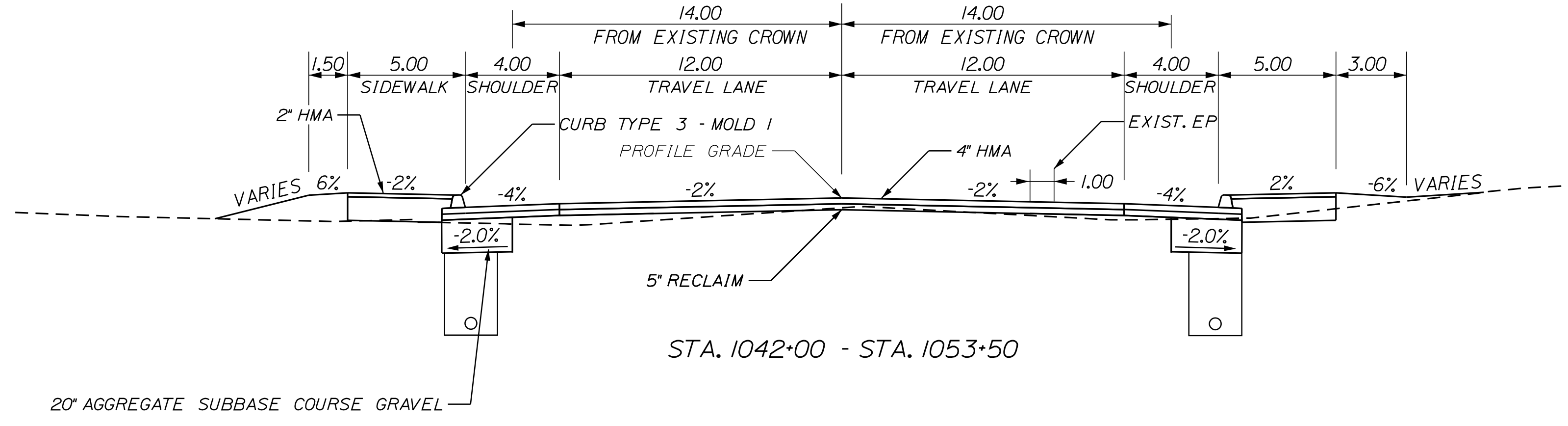
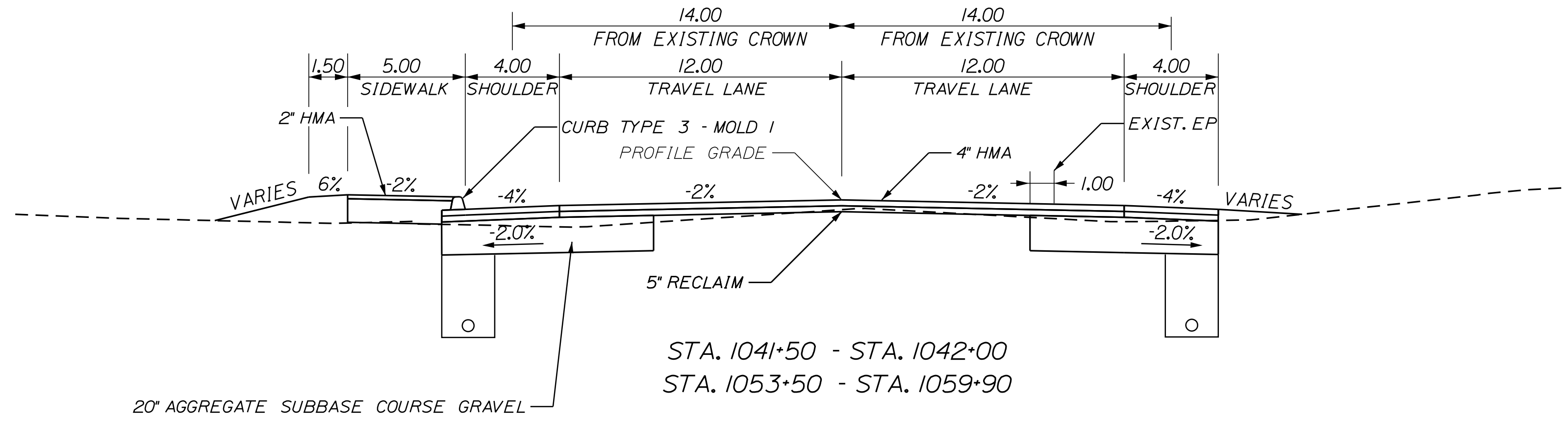

STATE OF MAINE
DEPARTMENT OF TRANSPORTATION
STP-1824(500)
PIN
PIN 18245.00
HIGHWAY PLANS

SIGNATURE
P.E. NUMBER
DATE

PROJ. MANAGER	DESIGNER	CHECKED	DATE
\$ProjectManager1	\$Designer1	\$Checker1	\$Date1
\$ProjectManager2	\$Designer2	\$Checker2	\$Date2
\$ProjectManager3	\$Designer3	\$Checker3	\$Date3
\$ProjectManager4	\$Designer4	\$Checker4	\$Date4
\$ProjectManager5	\$Designer5	\$Checker5	\$Date5
\$ProjectManager6	\$Designer6	\$Checker6	\$Date6
\$ProjectManager7	\$Designer7	\$Checker7	\$Date7
\$ProjectManager8	\$Designer8	\$Checker8	\$Date8
\$ProjectManager9	\$Designer9	\$Checker9	\$Date9
\$ProjectManager10	\$Designer10	\$Checker10	\$Date10

KINGFIELD
ROUTE 16\27
TYPICAL SECTIONS

SHEET NUMBER
5
OF 175

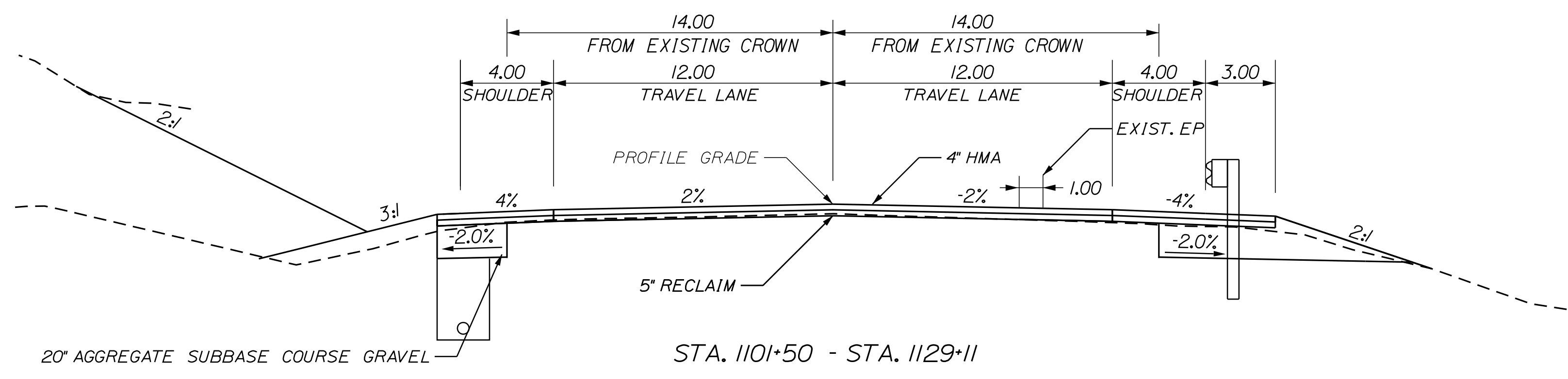
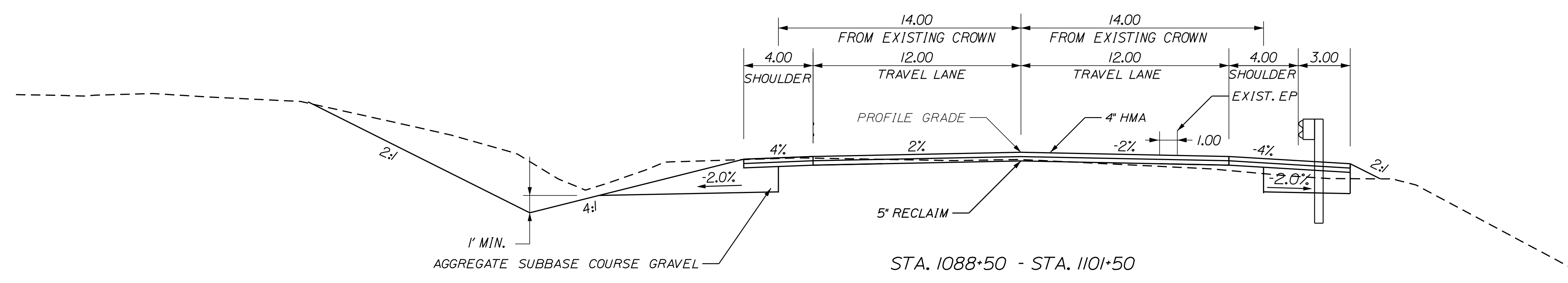
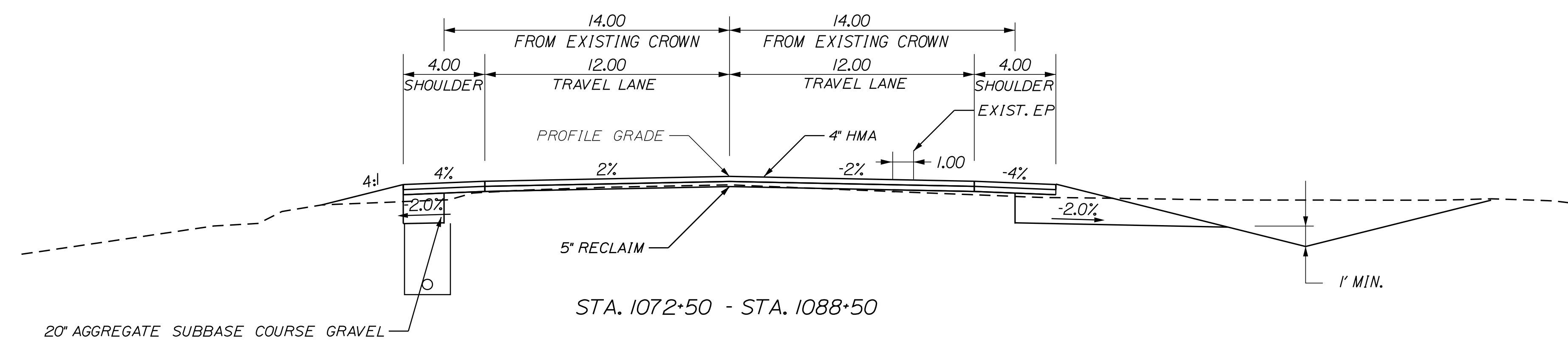
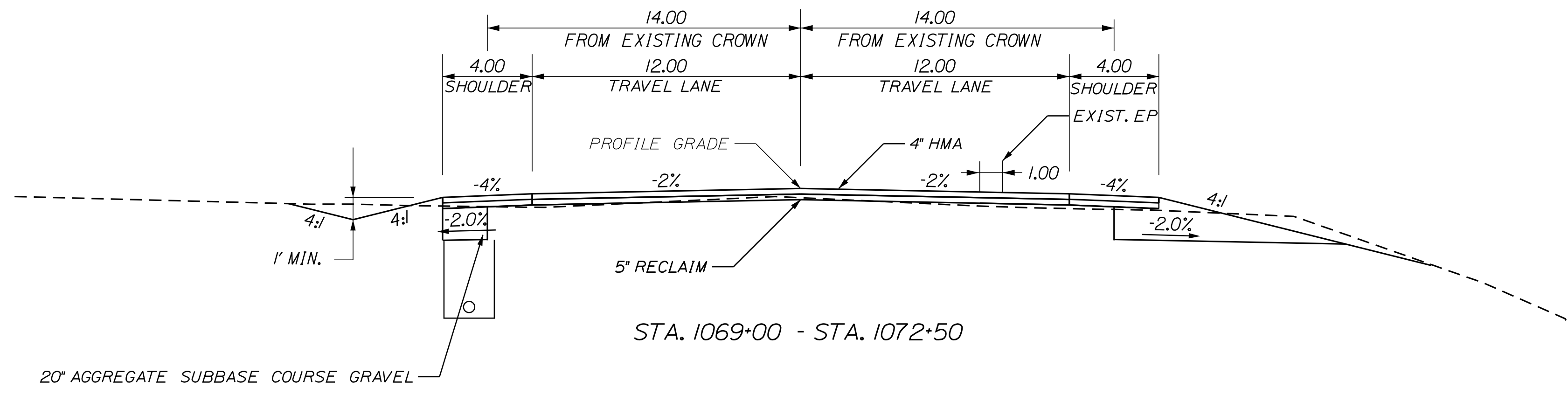

STATE OF MAINE		DEPARTMENT OF TRANSPORTATION	
STP-1824(500)		PIN PIN 18245.00	
HIGHWAY PLANS			
PROJ. MANAGER	DESIGNER	CHECKED	DATE
DESIGNED	DRAWN	DATE	
REVISIONS 1	REVISIONS 2	REVISIONS 3	REVISIONS 4
FIELD CHANGES			
SIGNATURE		P.E. NUMBER	
DATE			
KINGFIELD ROUTE 16\27 TYPICAL SECTIONS			
SHEET NUMBER			
6			
OF 175			

Date: 4/13/2016

Username:

Division: HIGHWAY

Filename: ... \Austn\Highway\007_HDPlant.dgn

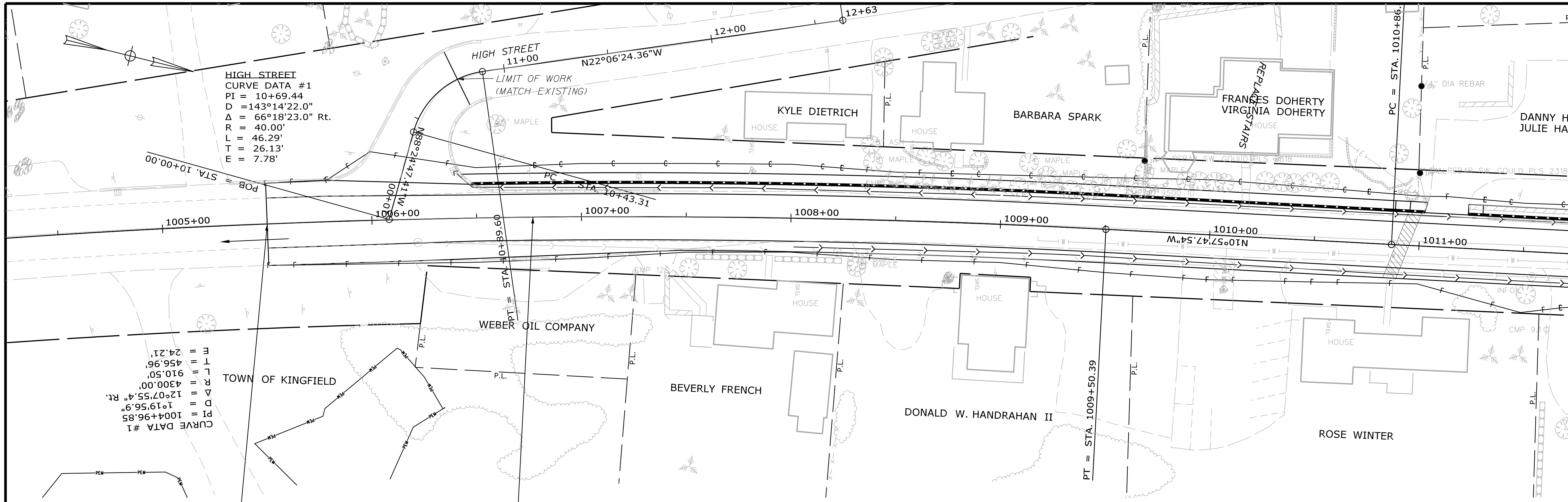

PROFILE

STATE OF MAINE
DEPARTMENT OF TRANSPORTATION
STP-1824(500)

SIGNATURE
P.E. NUMBER
DATE

PROJ. MANAGER	PROJ. MANAGER'S	BY	DATE
DESIGN-DETAILED	DESIGNER'S	\$Date	\$Date
CHECKED-REVIEWED	DESIGNER'S	\$Date	\$Date
DESIGNS-DETAILED	DESIGNER'S	\$Date	\$Date
DESIGNS-DETAILED	DESIGNER'S	\$Date	\$Date
REVISIONS 1	REVISOR'S	\$Date	\$Date
REVISIONS 2	REVISOR'S	\$Date	\$Date
REVISIONS 3	REVISOR'S	\$Date	\$Date
REVISIONS 4	REVISOR'S	\$Date	\$Date
FIELD CHANGES	FIELD CHANGES	\$Date	\$Date

KINGFIELD
ROUTE 16\27
PLANS

SHEET NUMBER
7
OF 175

PIN 18245.00
HIERARCHY PLANS

Date: 4/13/2016

Username:

Division: HIGHWAY

Filename: ... \Austn\Highway\008_HDPlan2.dgn

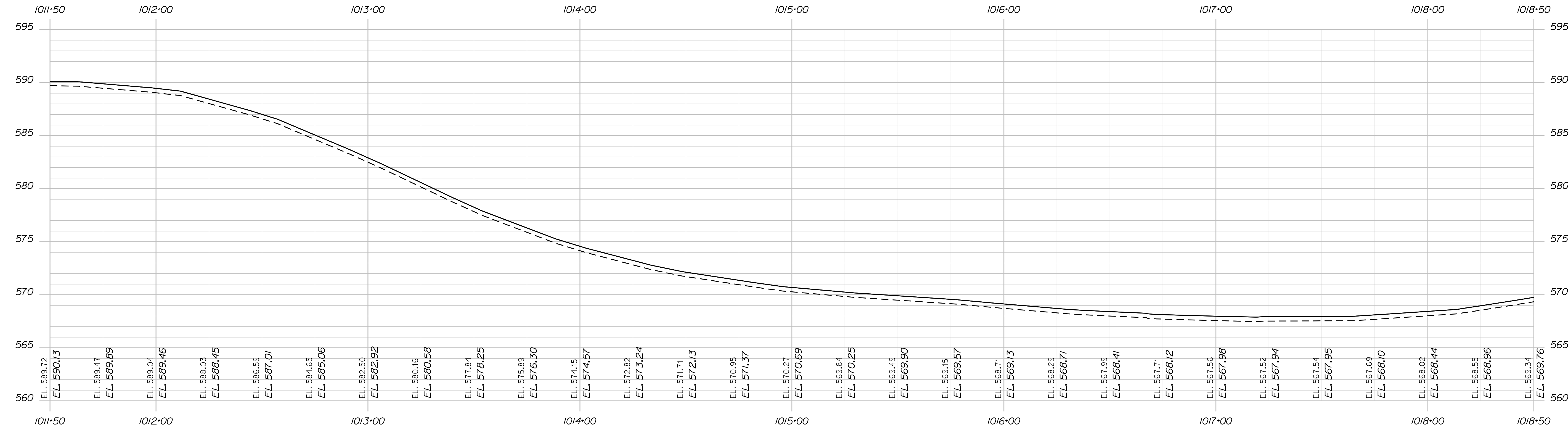
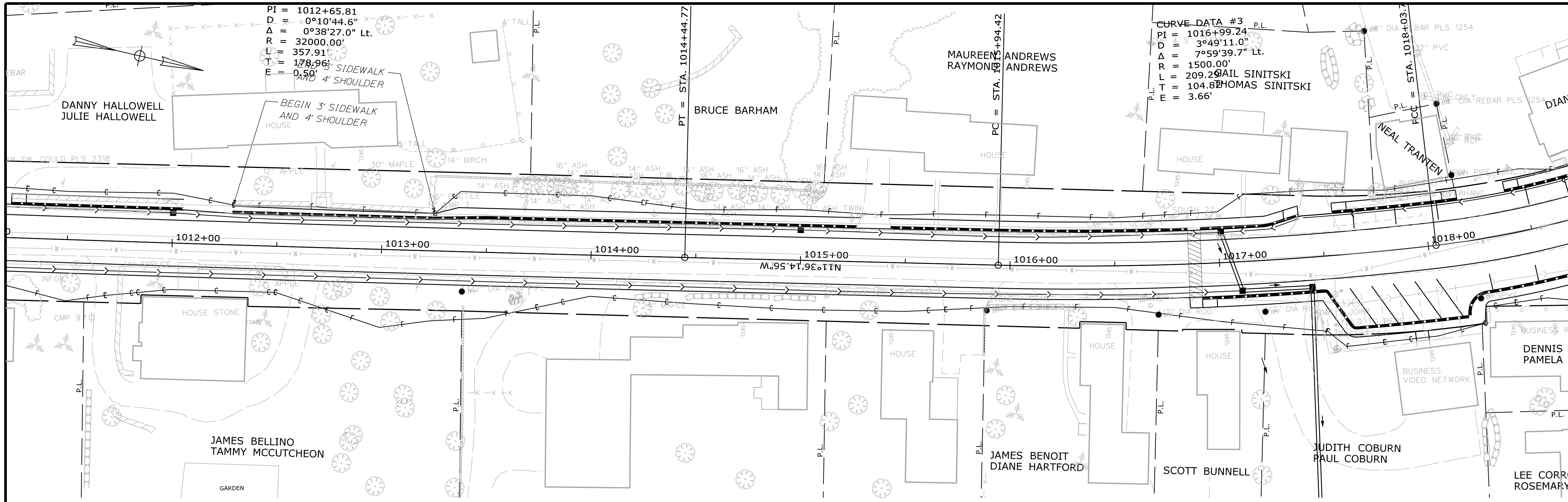

PROFILE

STATE OF MAINE
DEPARTMENT OF TRANSPORTATION
STP-1824(500)
PIN 18245.00
HIGHWAY PLANS

PROJ. MANAGER	PROJ. MANAGER'S	BY	DATE
DESIGN-DETAILED	DESIGNER	BY	DATE
CHECKED-REVIEWED	CHECKER	BY	DATE
DESIGN-DETAILED	DESIGNER	BY	DATE
DESIGN-DETAILED	DESIGNER	BY	DATE
REVISIONS 1	REVISION	BY	DATE
REVISIONS 2	REVISION	BY	DATE
REVISIONS 3	REVISION	BY	DATE
REVISIONS 4	REVISION	BY	DATE
FIELD CHANGES	FIELD CHANGES	BY	DATE

SIGNATURE
P.E. NUMBER
DATE

KINGFIELD
ROUTE 16\27
PLANS

SHEET NUMBER
8
OF 175

Date: 4/13/2016

Username:

Division: HIGHWAY

Filename: ... \Austn\Highway\010_HDPlan4.dgn

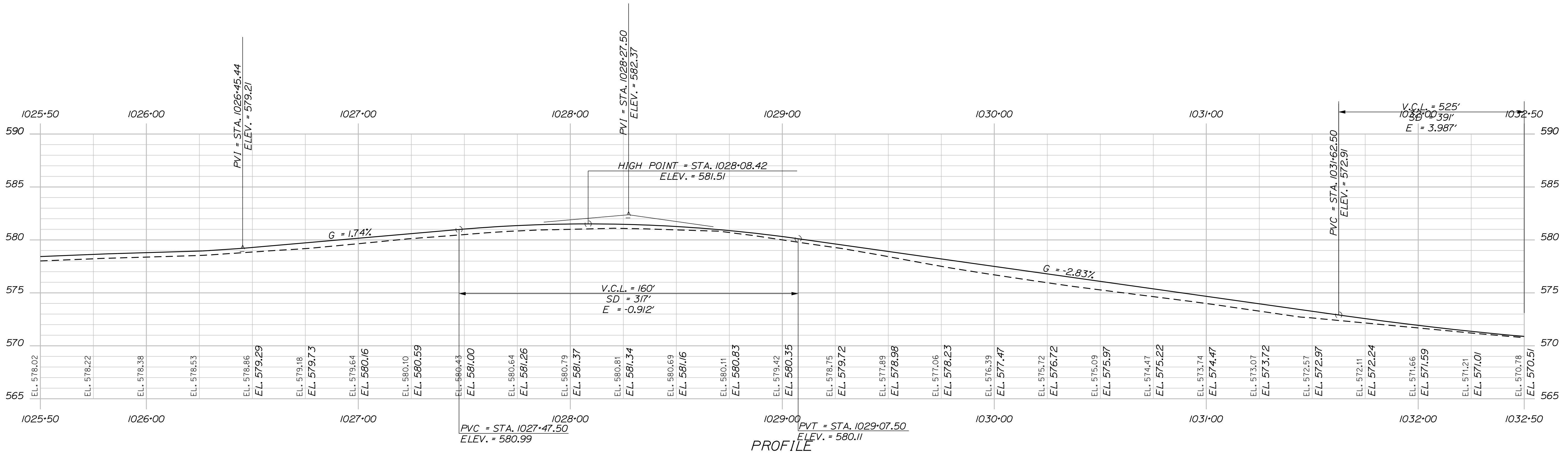
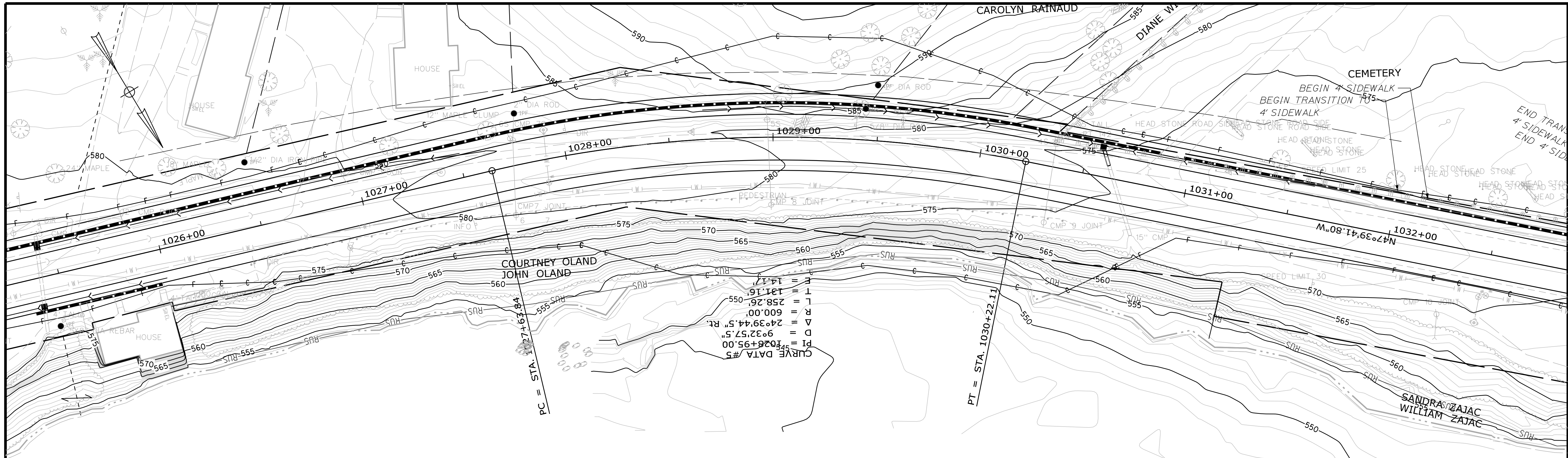

STATE OF MAINE
DEPARTMENT OF TRANSPORTATION
STP-1824(500)
PIN 18245.00
HIGHWAY PLANS

KINGFIELD
ROUTE 16\27
PLANS

PROJ. MANAGER	PROJ. MANAGERS	BY	DATE
DESIGN DETAIL	DESIGNER	DATE	DATE
CHECKED-REVIEWED	DESIGNER	DATE	DATE
DESIGN DETAIL	DESIGNER	DATE	DATE
DESIGN DETAIL	DESIGNER	DATE	DATE
REVISIONS 1	DESIGNER	DATE	DATE
REVISIONS 2	DESIGNER	DATE	DATE
REVISIONS 3	DESIGNER	DATE	DATE
REVISIONS 4	DESIGNER	DATE	DATE
FIELD CHANGES	DESIGNER	DATE	DATE

SHEET NUMBER
10
OF 175

Date: 4/13/2016

Username:

Division: HIGHWAY

Filename: ... \Austn\Highway\011_HDPlan5.dgn

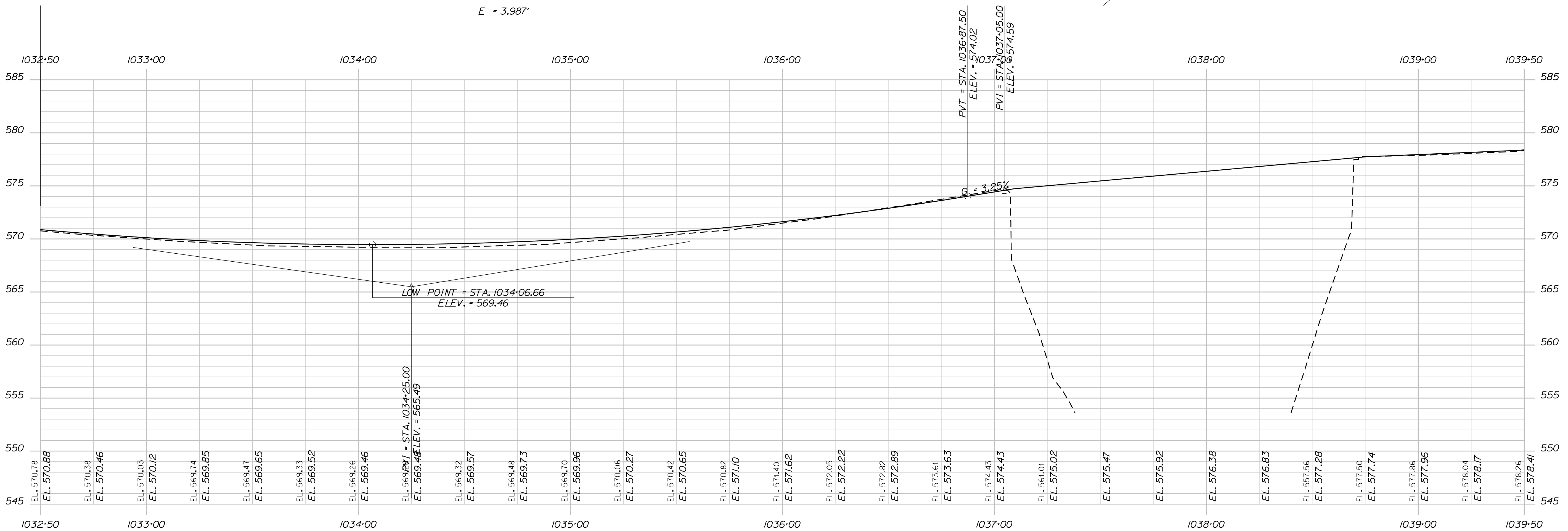
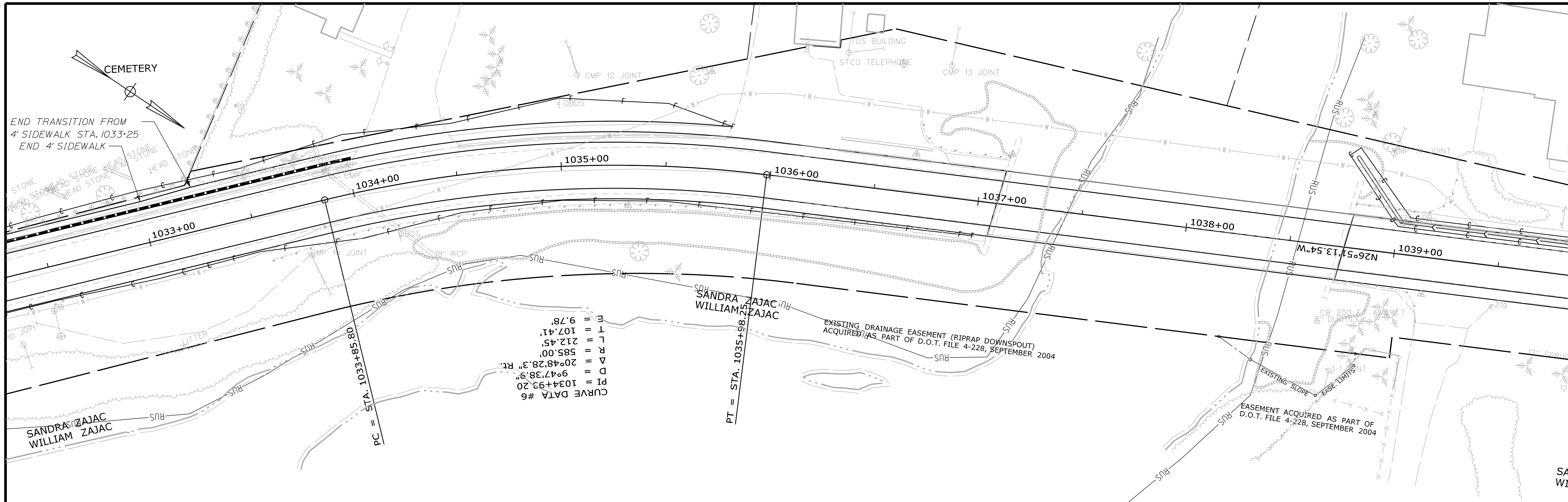

PROFILE

STATE OF MAINE		DEPARTMENT OF TRANSPORTATION		STP-1824(500)	
KINGFIELD		ROUTE 16\27		PLANS	
SHEET NUMBER		11		OF 175	
PIN		PIN 18245.00		HIGHWAY PLANS	
PROJ. MANAGER	BY	DATE	SIGNATURE	P.E. NUMBER	DATE
DESIGN-DETAILED	DESIGNER	DATE			
CHECKED-REVIEWED	CHECKER	DATE			
DESIGN-DETAILED	DESIGNER	DATE			
REVISIONS 1	REVISOR	DATE			
REVISIONS 2	REVISOR	DATE			
REVISIONS 3	REVISOR	DATE			
REVISIONS 4	REVISOR	DATE			
FIELD CHANGES	FIELD CHANGES				

Date: 4/13/2016

Username:

Division: HIGHWAY

Filename: ... \Austin\Highway\012_HDPlan6.dgn

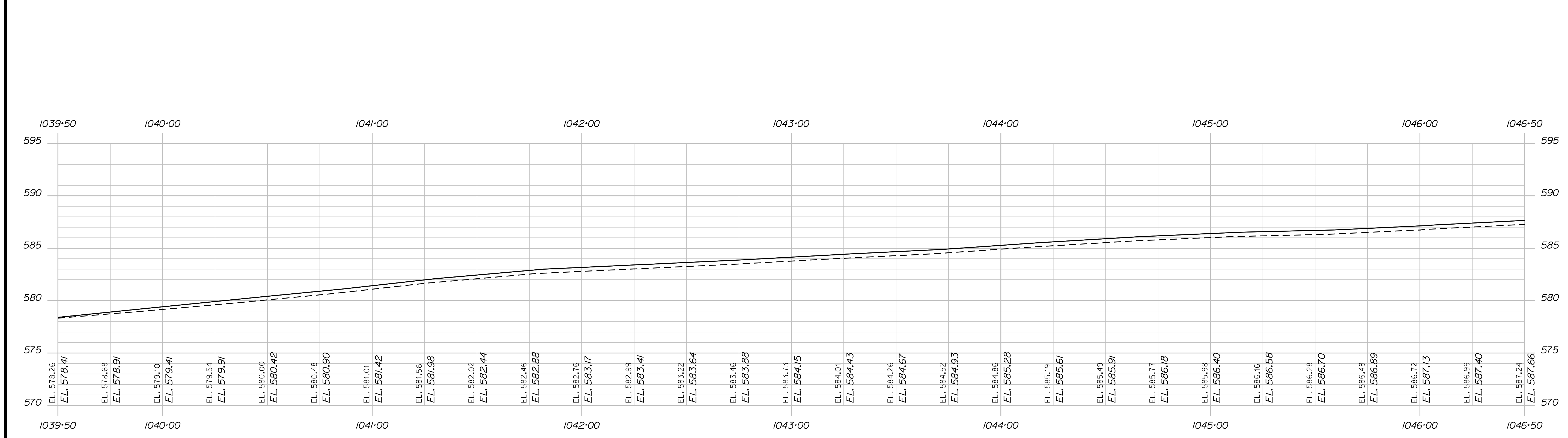
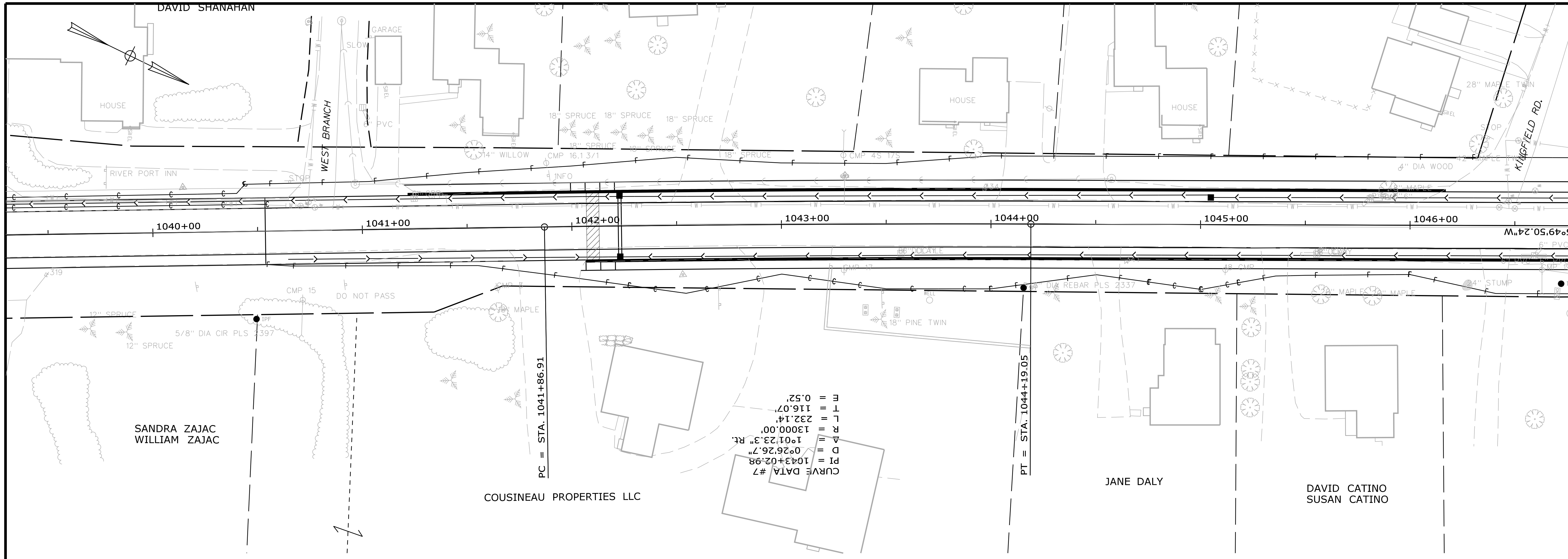

PROFILE

STATE OF MAINE
DEPARTMENT OF TRANSPORTATION
STP-1824(500)
PIN 18245.00
HIGHWAY PLANS

PROJ. MANAGER	PROJ. MANAGER'S	BY	DATE
DESIGN-DETAILED	DESIGNER'S	DATE	DATE
CHECKED-REVIEWED	DESIGNER'S	DATE	DATE
DESIGN-DETAILED	DESIGNER'S	DATE	DATE
DESIGN-DETAILED	DESIGNER'S	DATE	DATE
REVISIONS 1	DESIGNER'S	DATE	DATE
REVISIONS 2	DESIGNER'S	DATE	DATE
REVISIONS 3	DESIGNER'S	DATE	DATE
REVISIONS 4	DESIGNER'S	DATE	DATE
FIELD CHANGES	DESIGNER'S	DATE	DATE

KINGFIELD
ROUTE 16\27
PLANS

SHEET NUMBER
12
OF 175

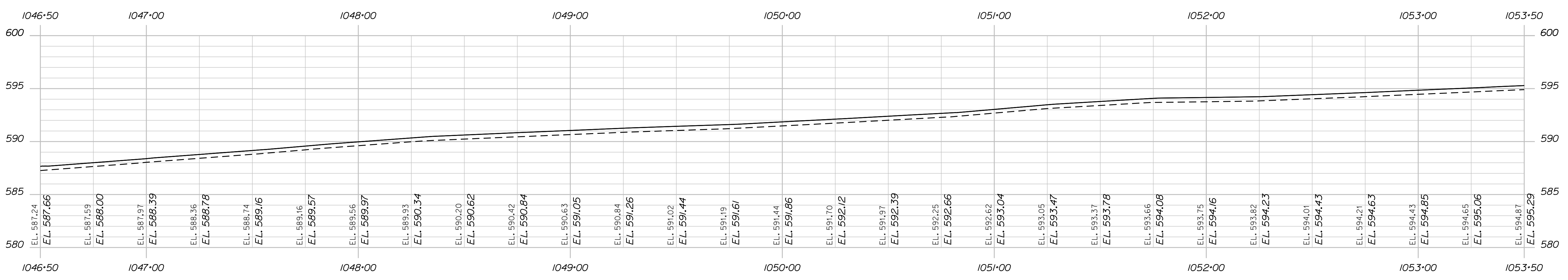
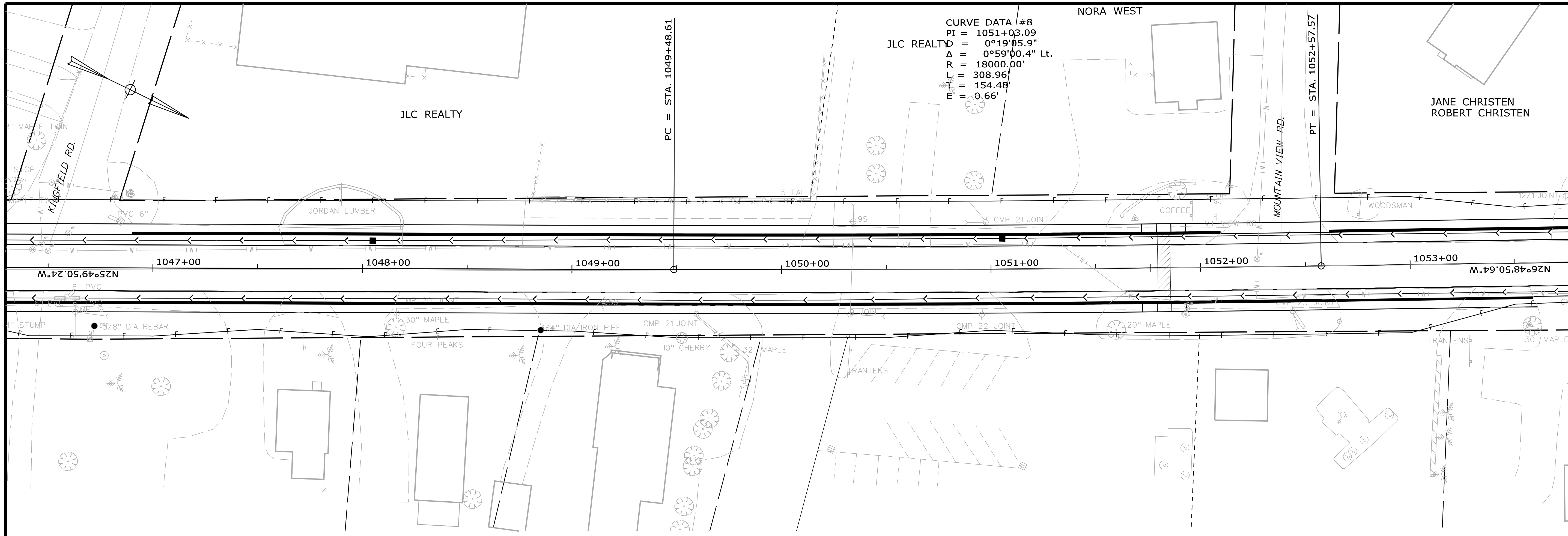

PROFILE

STATE OF MAINE
 DEPARTMENT OF TRANSPORTATION
 STP-1824(500)

PIN 18245.00
 HIERARCHY PLANS

KINGFIELD
 ROUTE 16\27
 PLANS

PROJ. MANAGER	PROJ. MANAGER'S	BY	DATE
DESIGN-DETAILED	DESIGNER	BY	DATE
CHECKED-REVIEWED	DESIGNER	BY	DATE
DESIGN-DETAILED	DESIGNER	BY	DATE
REVISIONS 1	DESIGNER	BY	DATE
REVISIONS 2	DESIGNER	BY	DATE
REVISIONS 3	DESIGNER	BY	DATE
REVISIONS 4	DESIGNER	BY	DATE
FIELD CHANGES	FIELD CHANGES	BY	DATE

SHEET NUMBER
13
 OF 175

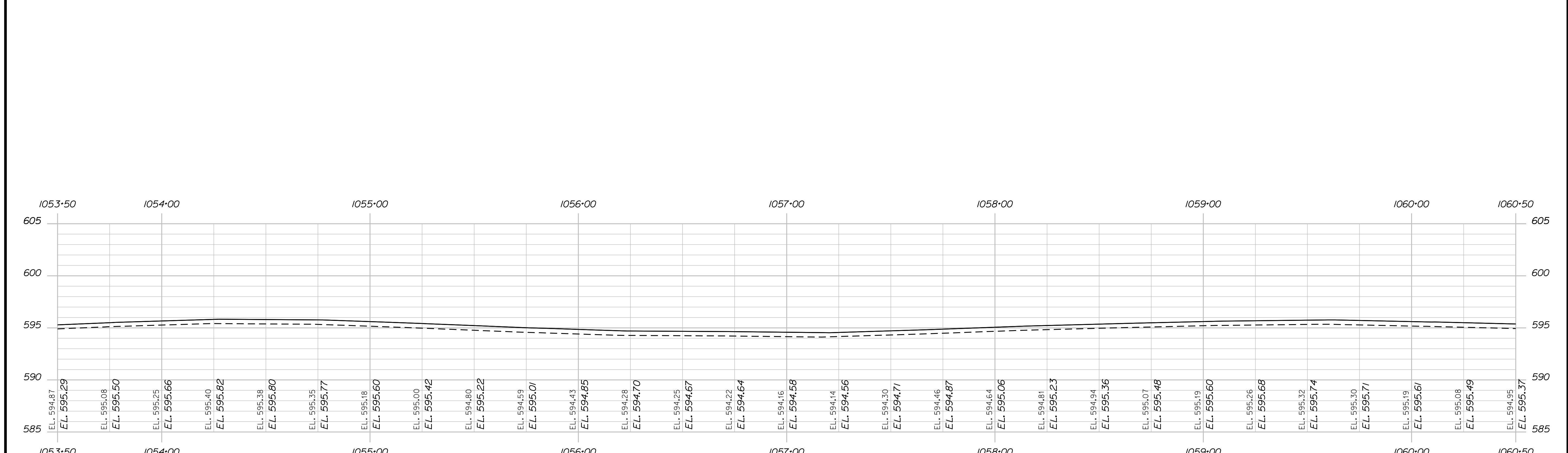
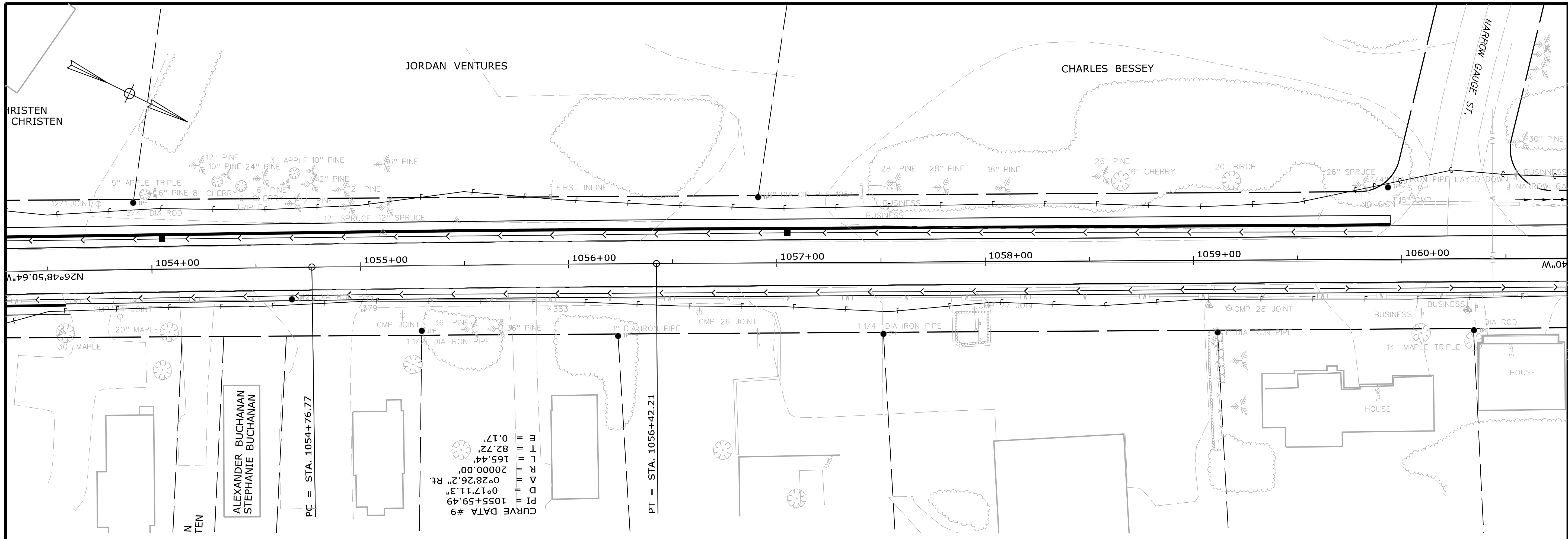

PROFILE

STATE OF MAINE
DEPARTMENT OF TRANSPORTATION
STP-1824(500)
PIN
PIN 18245.00
HIGHWAY PLANS

PROJ. MANAGER	PROJ. MANAGER'S	BY	DATE
DESIGN-DETAILED	DESIGNER'S	DATE	DATE
CHECKED-REVIEWED	DESIGNER'S	DATE	DATE
DESIGN-DETAILED	DESIGNER'S	DATE	DATE
DESIGN-DETAILED	DESIGNER'S	DATE	DATE
REVISIONS 1	REVISION'S	DATE	DATE
REVISIONS 2	REVISION'S	DATE	DATE
REVISIONS 3	REVISION'S	DATE	DATE
REVISIONS 4	REVISION'S	DATE	DATE
FIELD CHANGES	FIELD CHANGES	DATE	DATE

KINGFIELD
ROUTE 16\27
PLANS

SHEET NUMBER
14
OF 175

Date: 4/13/2016

Username:

Division: HIGHWAY

Filename: ... \Austn\Highway\015_HDPlan9.dgn

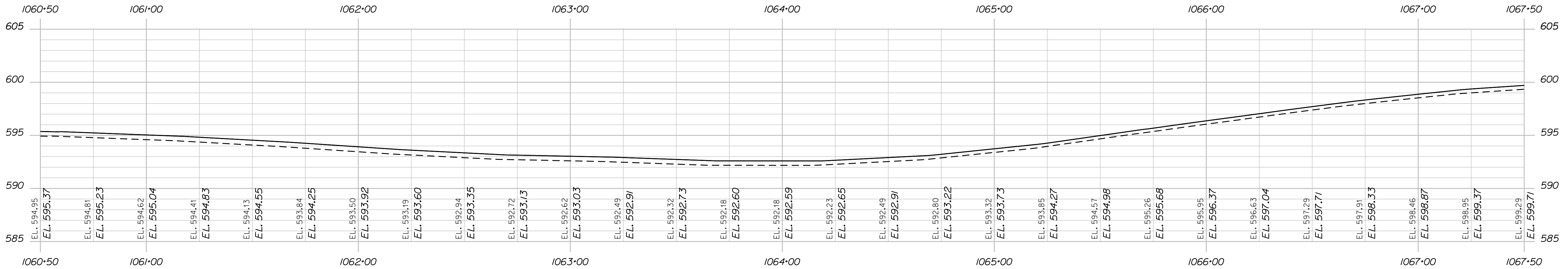
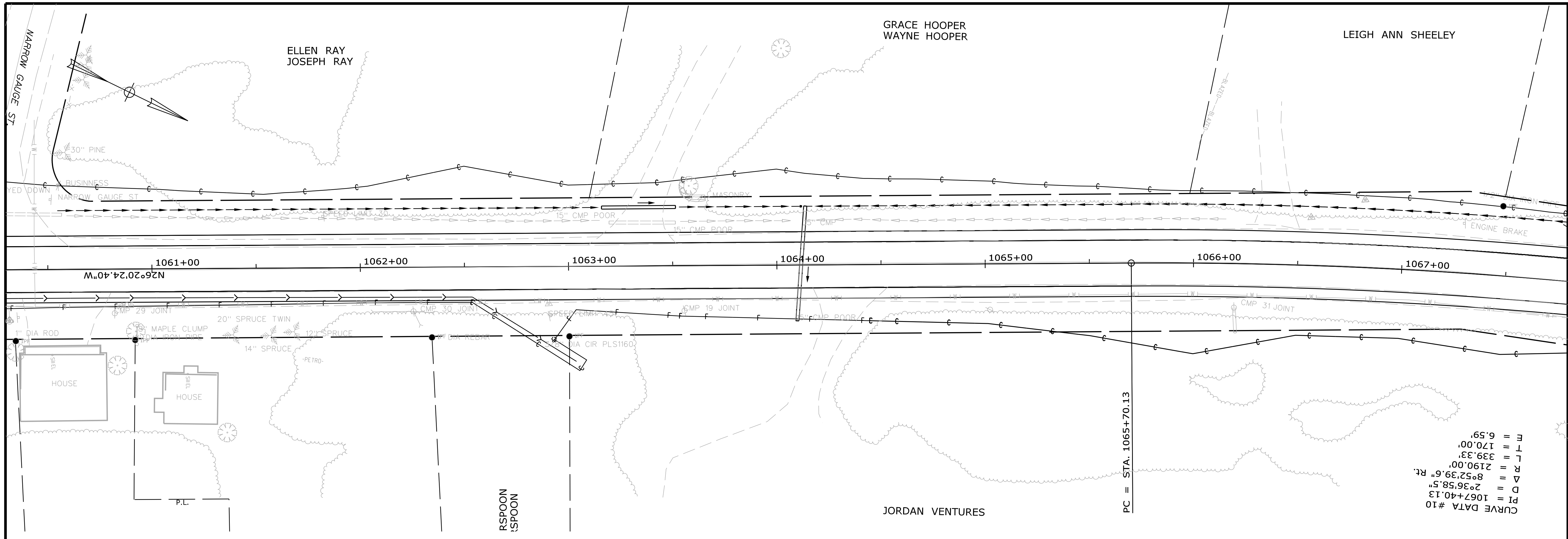

PROFILE

CURVE DATA #10
 PI = 1067+40.13
 Δ = 2°36'58.5"
 R = 852739.6' Rt.
 L = 2190.00'
 T = 339.33'
 E = 170.00'
 M = 6.59'

STATE OF MAINE
 DEPARTMENT OF TRANSPORTATION
 STP-1824(500)
 PIN 18245.00
 HIERARCHY PLANS

PROJ. MANAGER	PROJ. MANAGER'S	BY	DATE
DESIGN-DETAILED	DESIGNER'S	DRAWN	DATE
CHECKED-REVIEWED	DESIGNER'S	DATE	
DESIGN-DETAILED	DESIGNER'S	DATE	
REVISIONS 1	DESIGNER'S	DATE	
REVISIONS 2	DESIGNER'S	DATE	
REVISIONS 3	DESIGNER'S	DATE	
REVISIONS 4	DESIGNER'S	DATE	
FIELD CHANGES	DESIGNER'S	DATE	

KINGFIELD
 ROUTE 16\27
 PLANS

SHEET NUMBER
 15
 OF 175

Date: 4/13/2016

Username:

Division: HIGHWAY

Filename: ... \Austn\Highway\016_HDPlan10.dgn

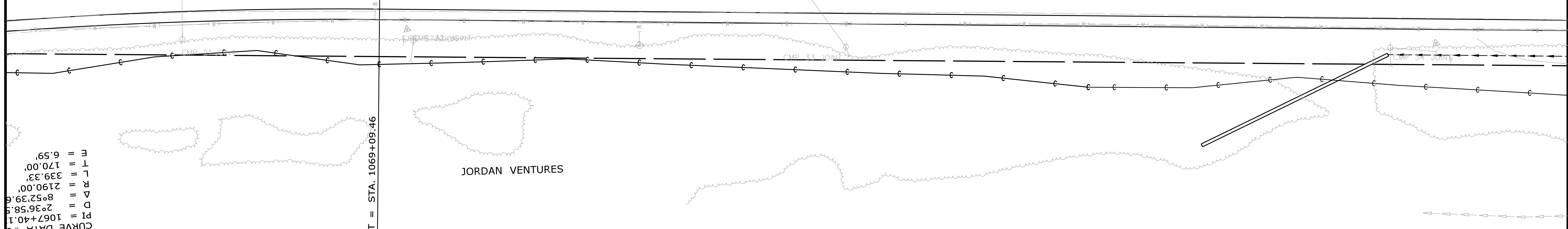
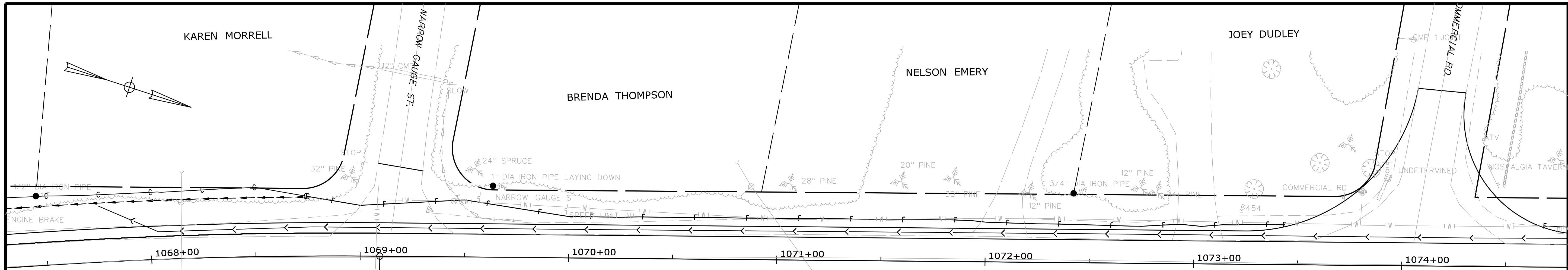

CURVE DATA #1
 PT = 1067+40.1
 Δ = 2°36'58.5"
 R = 852.39.6
 D = 2190.00'
 L = 339.33'
 T = 170.00'
 E = 6.59'

PT = STA. 1069+09.46

Station	Elevation
1067.50	EL. 599.29
1068.00	EL. 599.59
1068.00	EL. 600.00
1068.00	EL. 599.67
1068.00	EL. 600.09
1068.00	EL. 599.78
1068.00	EL. 600.19
1068.00	EL. 600.09
1068.00	EL. 600.51
1068.00	EL. 600.38
1068.00	EL. 600.80
1069.00	EL. 600.79
1069.00	EL. 601.21
1069.00	EL. 601.20
1069.00	EL. 601.61
1069.00	EL. 601.67
1069.00	EL. 602.08
1069.00	EL. 602.11
1069.00	EL. 602.53
1070.00	EL. 602.48
1070.00	EL. 602.90
1070.00	EL. 602.84
1070.00	EL. 603.26
1070.00	EL. 603.13
1070.00	EL. 603.55
1070.00	EL. 603.42
1070.00	EL. 603.84
1071.00	EL. 603.64
1071.00	EL. 604.05
1071.00	EL. 603.83
1071.00	EL. 604.25
1071.00	EL. 603.92
1071.00	EL. 604.34
1072.00	EL. 604.00
1072.00	EL. 604.42
1072.00	EL. 604.05
1072.00	EL. 604.47
1072.00	EL. 604.10
1072.00	EL. 604.52
1073.00	EL. 604.25
1073.00	EL. 604.67
1073.00	EL. 604.40
1073.00	EL. 604.82
1073.00	EL. 604.57
1073.00	EL. 604.98
1074.00	EL. 604.74
1074.00	EL. 605.15
1074.00	EL. 604.92
1074.00	EL. 605.34
1074.00	EL. 605.10
1074.00	EL. 605.52
1074.00	EL. 605.25
1074.00	EL. 605.67
1074.00	EL. 605.38
1074.00	EL. 605.80
1074.50	EL. 605.44
1074.50	EL. 605.85

PROFILE

STATE OF MAINE
 DEPARTMENT OF TRANSPORTATION
 STP-1824(500)
 PIN 18245.00
 HIERARCHY PLANS

PROJ. MANAGER	PROJ. MANAGER'S	BY	DATE
DESIGN-DETAILED	DESIGNER'S	DATE	DATE
CHECKED-REVIEWED	DESIGNER'S	DATE	DATE
DESIGN-DETAILED	DESIGNER'S	DATE	DATE
DESIGN-DETAILED	DESIGNER'S	DATE	DATE
REVISIONS 1	DESIGNER'S	DATE	DATE
REVISIONS 2	DESIGNER'S	DATE	DATE
REVISIONS 3	DESIGNER'S	DATE	DATE
REVISIONS 4	DESIGNER'S	DATE	DATE
FIELD CHANGES	DESIGNER'S	DATE	DATE

KINGFIELD
 ROUTE 16\27
 PLANS

SHEET NUMBER
 16
 OF 175

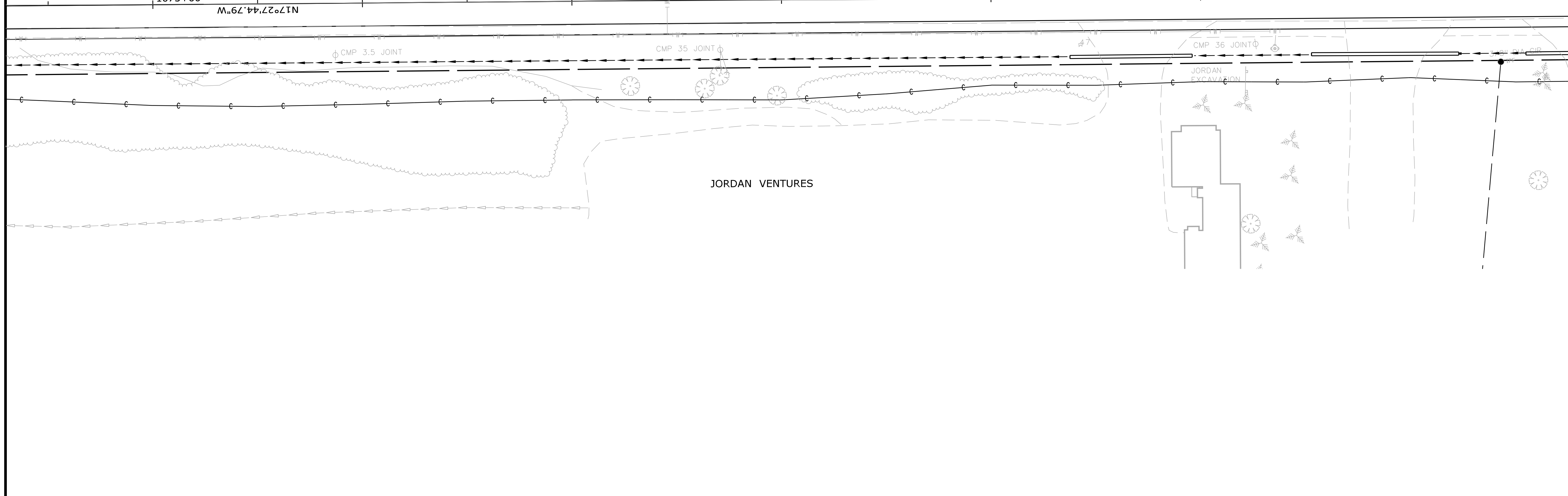

STATE OF MAINE
DEPARTMENT OF TRANSPORTATION
STP-1824(500)
PIN 18245.00
HIGHWAY PLANS

PROJ. MANAGER	PROJ. MANAGER'S	BY	DATE
DESIGN-DETAILED	DESIGNER	BY	DATE
CHECKED-REVIEWED	DESIGNER	BY	DATE
DESIGN-DETAILED	DESIGNER	BY	DATE
DESIGN-DETAILED	DESIGNER	BY	DATE
REVISIONS 1	DESIGNER	BY	DATE
REVISIONS 2	DESIGNER	BY	DATE
REVISIONS 3	DESIGNER	BY	DATE
REVISIONS 4	DESIGNER	BY	DATE
FIELD CHANGES	DESIGNER	BY	DATE

KINGFIELD
ROUTE 16\27
PLANS

SHEET NUMBER
17
OF 175

Date: 4/13/2016

Username:

Division: HIGHWAY

Filename: ... \Austin\Highway\018_HDPlan12.dgn

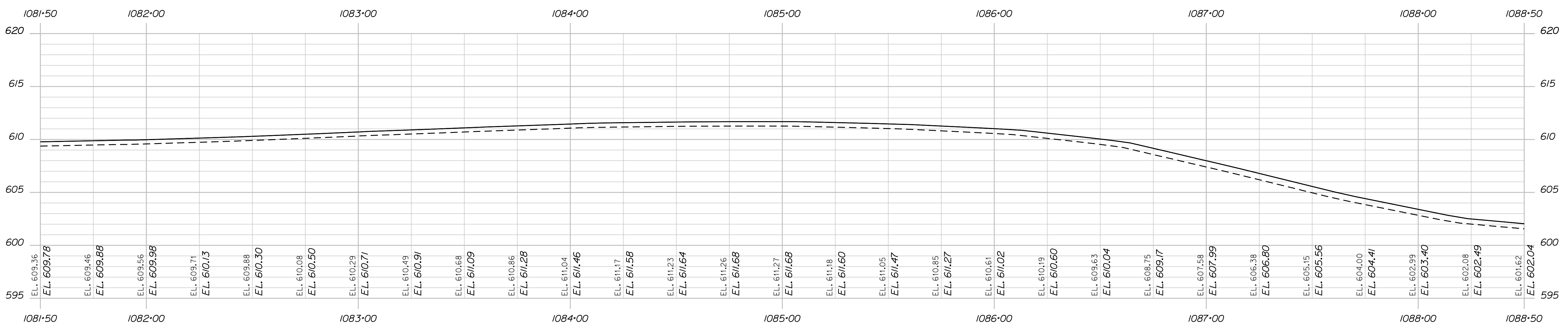
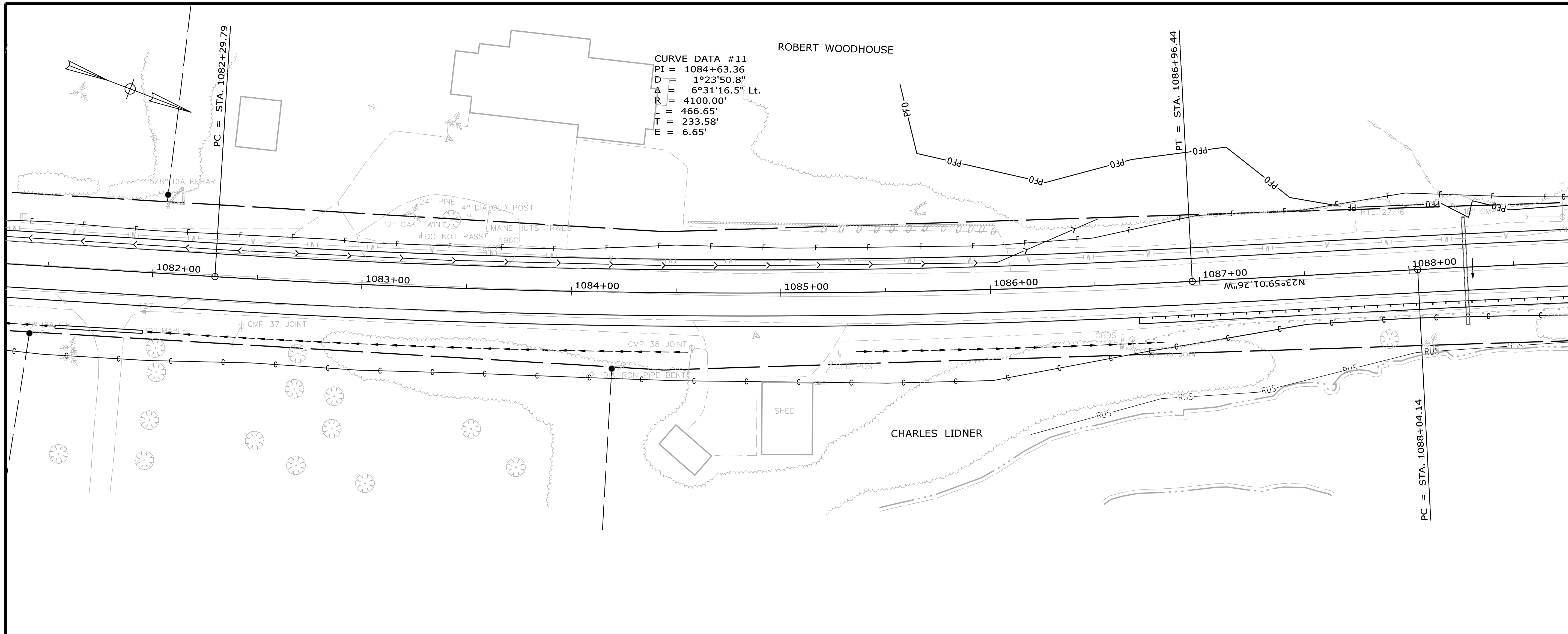

PROFILE

STATE OF MAINE
 DEPARTMENT OF TRANSPORTATION
 STP-1824(500)
 PIN 18245.00
 HIERARCHY PLANS

DESIGN DETAIL	DESIGNER	CHECKED	DATE
DESIGN DETAIL 1	DESIGNER 1	CHECKED 1	DATE 1
DESIGN DETAIL 2	DESIGNER 2	CHECKED 2	DATE 2
DESIGN DETAIL 3	DESIGNER 3	CHECKED 3	DATE 3
DESIGN DETAIL 4	DESIGNER 4	CHECKED 4	DATE 4

KINGFIELD
 ROUTE 16\27
 PLANS

SHEET NUMBER
18
 OF 175

Date: 4/13/2016

Username:

Division: HIGHWAY

Filename: ... \Austin\Highway\019_HDPlan13.dgn

L = 49.02'
T = 24.55'
E = 0.86'

THIS PLAN WAS PREPARED IN CONNECTION WITH THE DEPARTMENT'S ACQUISITION OF REAL PROPERTY FOR TRANSPORTATION PURPOSES. IT CANNOT BE USED TO ESTABLISH LEGAL BOUNDARIES BETWEEN ABUTTING PROPERTY OWNERS.

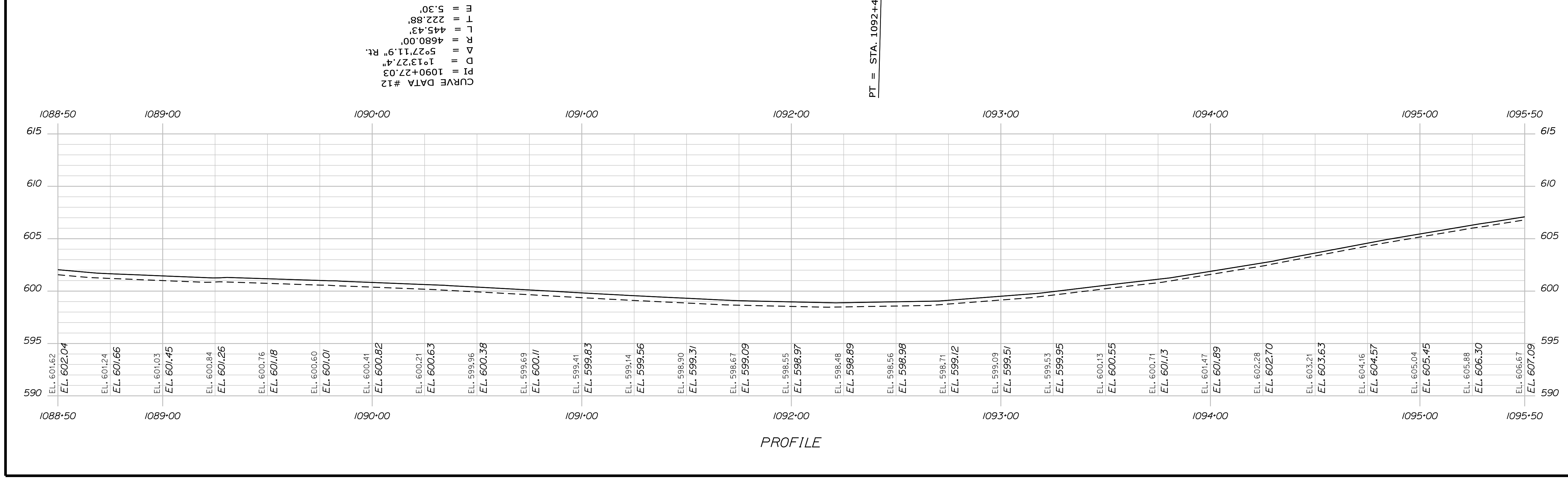
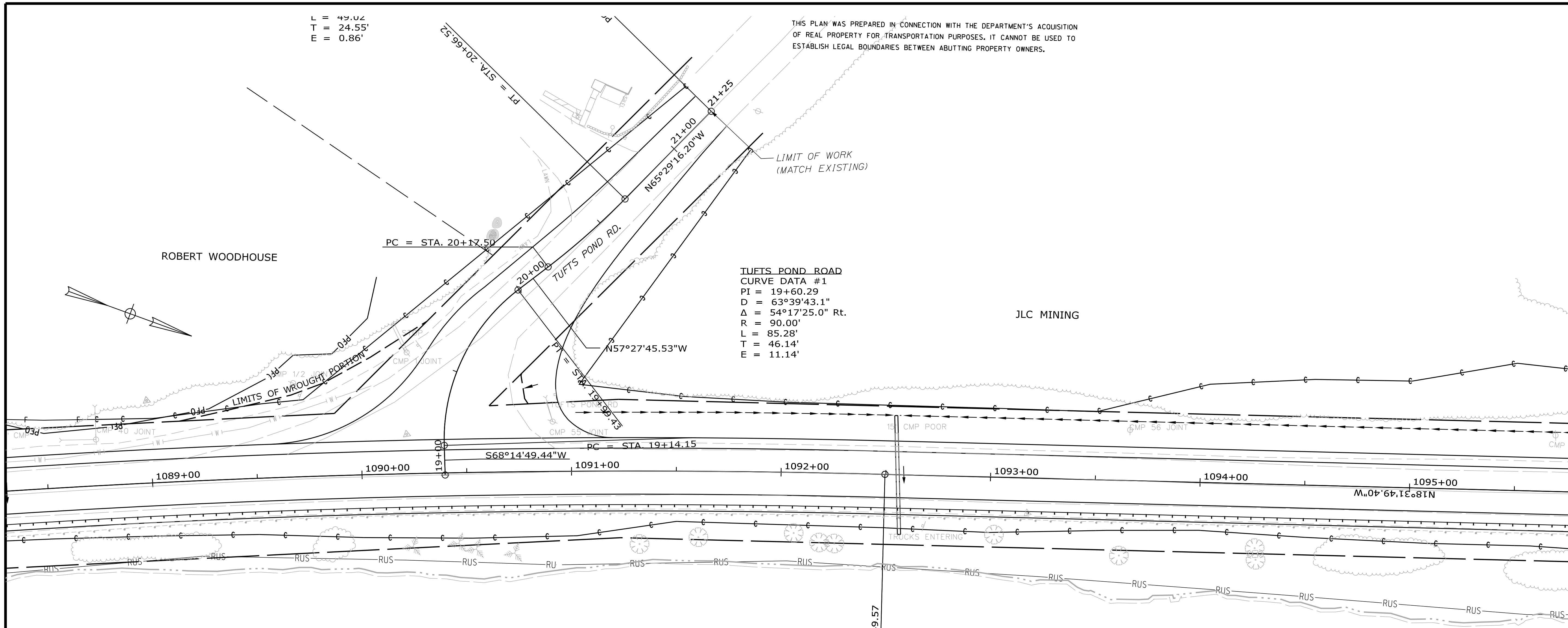

STATE OF MAINE
 DEPARTMENT OF TRANSPORTATION
 STP-1824(500)
 PIN 18245.00
 HIGHWAY PLANS

KINGFIELD
 ROUTE 16\27
 PLANS

PROJ. MANAGER	BY	DATE
DESIGNER	DESIGNER	DATE
CHECKED	CHECKED	DATE
DESIGNED	DESIGNED	DATE
REVISIONS 1	REVISIONS 1	DATE
REVISIONS 2	REVISIONS 2	DATE
REVISIONS 3	REVISIONS 3	DATE
REVISIONS 4	REVISIONS 4	DATE
FIELD CHANGES	FIELD CHANGES	DATE

SHEET NUMBER
 19
 OF 175

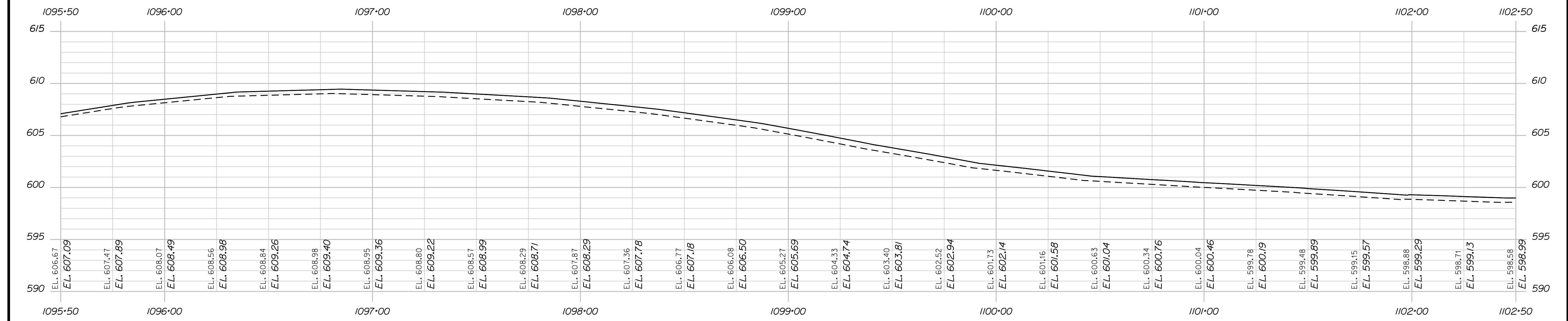
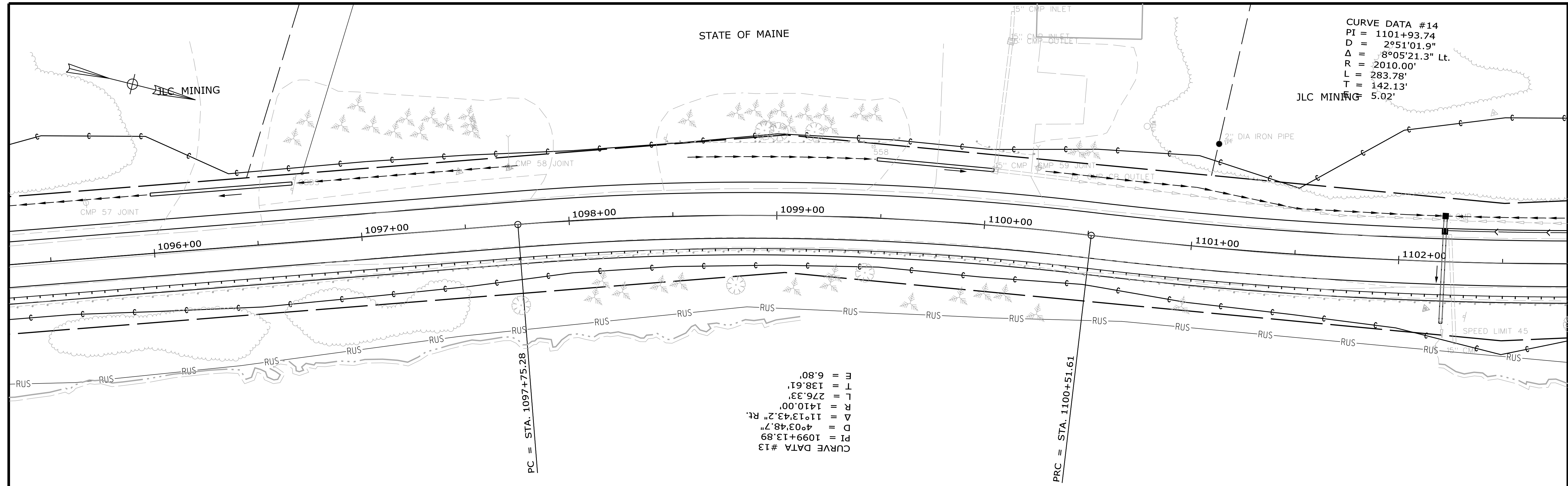

PROFILE

CURVE DATA #14
 PI = 1101+93.74
 D = 2°51'01.9"
 Δ = 8°05'21.3" Lt.
 R = 2010.00'
 L = 283.78'
 T = 142.13'
 JLC MINING 5.02'

CURVE DATA #13
 PI = 1099+13.89
 D = 4°03'48.7"
 Δ = 11°13'43.2" Rt.
 R = 1410.00'
 L = 276.33'
 T = 138.61'
 E = 6.80'

PC = STA. 1097+75.28

PRC = STA. 1100+51.61

STATE OF MAINE
 DEPARTMENT OF TRANSPORTATION
 STP-1824(500)
 PIN 18245.00
 HIERARCHIC PLANS

PROJ. MANAGER	PROJ. MANAGER'S	BY	DATE
DESIGN-DETAILED	DESIGNER'S	DATE	DATE
CHECKED-REVIEWED	DESIGNER'S	DATE	DATE
DESIGN-DETAILED	DESIGNER'S	DATE	DATE
REVISIONS 1	DESIGNER'S	DATE	DATE
REVISIONS 2	DESIGNER'S	DATE	DATE
REVISIONS 3	DESIGNER'S	DATE	DATE
REVISIONS 4	DESIGNER'S	DATE	DATE
FIELD CHANGES	FIELD CHANGES	DATE	DATE

KINGFIELD
 ROUTE 16\27
 PLANS

SHEET NUMBER
 20
 OF 175

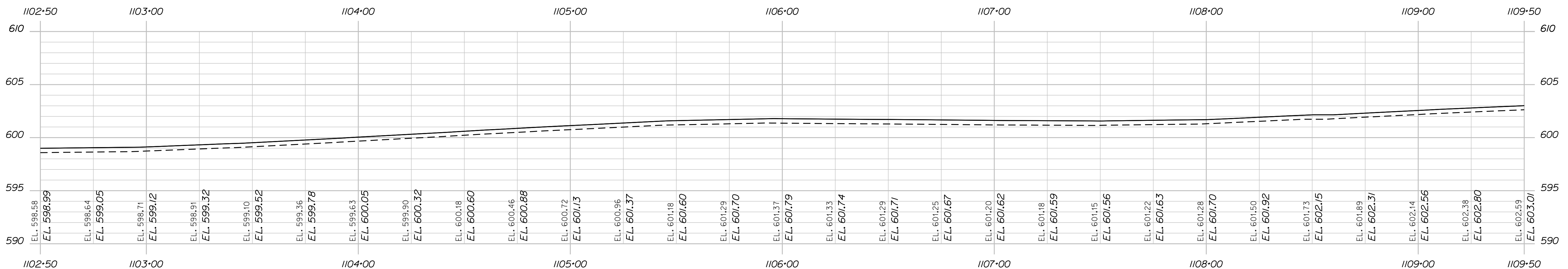
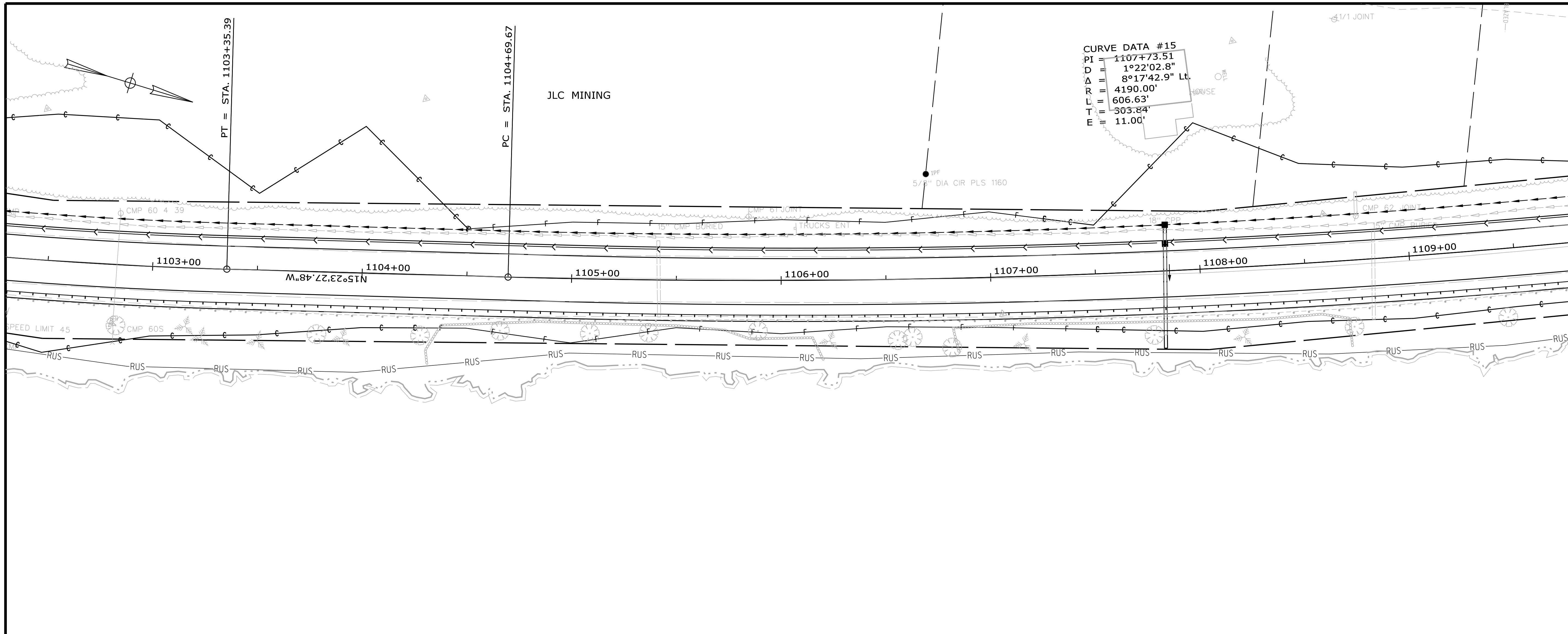

PROFILE

STATE OF MAINE																																												
DEPARTMENT OF TRANSPORTATION																																												
STP-1824(500)																																												
PIN	PIN 18245.00																																											
HIGHWAY PLANS																																												
<table border="1" style="width: 100%; border-collapse: collapse;"> <thead> <tr> <th>PROJ. MANAGER</th> <th>PROJ. MANAGER'S</th> <th>BY</th> <th>DATE</th> </tr> </thead> <tbody> <tr> <td>DESIGN-DETAILED</td> <td>DESIGNER'S</td> <td>DATE</td> <td>DATE</td> </tr> <tr> <td>CHECKED-REVIEWED</td> <td>DESIGNER'S</td> <td>DATE</td> <td>DATE</td> </tr> <tr> <td>DESIGN-DETAILED</td> <td>DESIGNER'S</td> <td>DATE</td> <td>DATE</td> </tr> <tr> <td>DESIGN-DETAILED</td> <td>DESIGNER'S</td> <td>DATE</td> <td>DATE</td> </tr> <tr> <td>REVISIONS 1</td> <td>DESIGNER'S</td> <td>DATE</td> <td>DATE</td> </tr> <tr> <td>REVISIONS 2</td> <td>DESIGNER'S</td> <td>DATE</td> <td>DATE</td> </tr> <tr> <td>REVISIONS 3</td> <td>DESIGNER'S</td> <td>DATE</td> <td>DATE</td> </tr> <tr> <td>REVISIONS 4</td> <td>DESIGNER'S</td> <td>DATE</td> <td>DATE</td> </tr> <tr> <td>FIELD CHANGES</td> <td>FIELD CHANGES</td> <td></td> <td></td> </tr> </tbody> </table>	PROJ. MANAGER	PROJ. MANAGER'S	BY	DATE	DESIGN-DETAILED	DESIGNER'S	DATE	DATE	CHECKED-REVIEWED	DESIGNER'S	DATE	DATE	DESIGN-DETAILED	DESIGNER'S	DATE	DATE	DESIGN-DETAILED	DESIGNER'S	DATE	DATE	REVISIONS 1	DESIGNER'S	DATE	DATE	REVISIONS 2	DESIGNER'S	DATE	DATE	REVISIONS 3	DESIGNER'S	DATE	DATE	REVISIONS 4	DESIGNER'S	DATE	DATE	FIELD CHANGES	FIELD CHANGES			<table border="1" style="width: 100%; border-collapse: collapse;"> <tr> <td style="text-align: center;">SIGNATURE</td> </tr> <tr> <td style="text-align: center;">P.E. NUMBER</td> </tr> <tr> <td style="text-align: center;">DATE</td> </tr> </table>	SIGNATURE	P.E. NUMBER	DATE
PROJ. MANAGER	PROJ. MANAGER'S	BY	DATE																																									
DESIGN-DETAILED	DESIGNER'S	DATE	DATE																																									
CHECKED-REVIEWED	DESIGNER'S	DATE	DATE																																									
DESIGN-DETAILED	DESIGNER'S	DATE	DATE																																									
DESIGN-DETAILED	DESIGNER'S	DATE	DATE																																									
REVISIONS 1	DESIGNER'S	DATE	DATE																																									
REVISIONS 2	DESIGNER'S	DATE	DATE																																									
REVISIONS 3	DESIGNER'S	DATE	DATE																																									
REVISIONS 4	DESIGNER'S	DATE	DATE																																									
FIELD CHANGES	FIELD CHANGES																																											
SIGNATURE																																												
P.E. NUMBER																																												
DATE																																												
<h2 style="margin: 0;">KINGFIELD</h2> <h3 style="margin: 0;">ROUTE 16\27</h3> <h1 style="margin: 0;">PLANS</h1>																																												
SHEET NUMBER																																												
21																																												
OF 175																																												

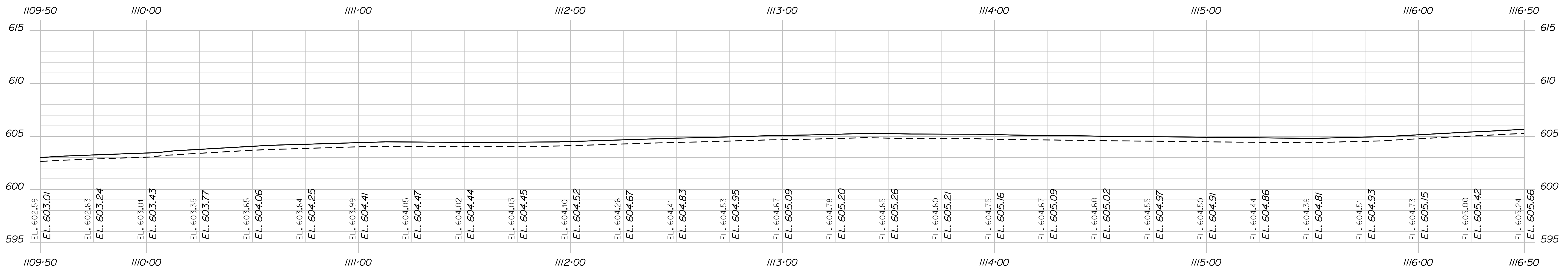
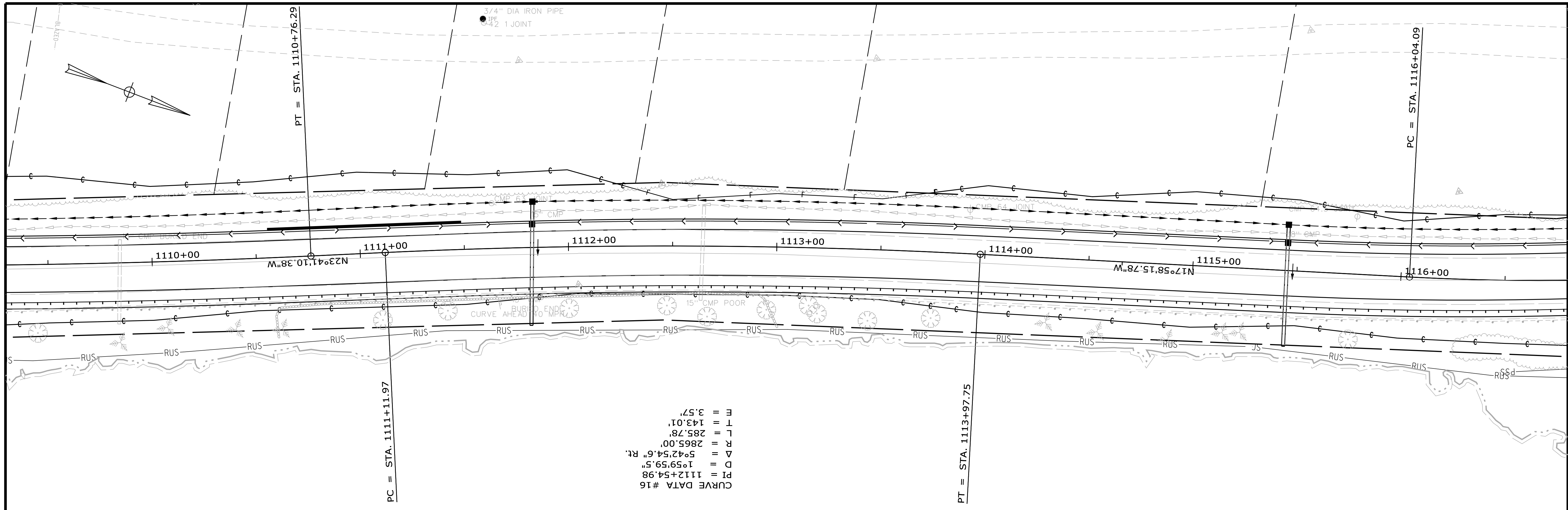

STATE OF MAINE
DEPARTMENT OF TRANSPORTATION
STP-1824(500)
PIN
PIN 18245.00
HIGHWAY PLANS

PROJ. MANAGER	PROJ. MANAGER'S	BY	DATE
DESIGN-DETAILED	DESIGNER'S	DATE	DATE
CHECKED-REVIEWED	DESIGNER'S	DATE	DATE
DESIGN-DETAILED	DESIGNER'S	DATE	DATE
DESIGN-DETAILED	DESIGNER'S	DATE	DATE
REVISIONS 1	DESIGNER'S	DATE	DATE
REVISIONS 2	DESIGNER'S	DATE	DATE
REVISIONS 3	DESIGNER'S	DATE	DATE
REVISIONS 4	DESIGNER'S	DATE	DATE
FIELD CHANGES	DESIGNER'S	DATE	DATE

SIGNATURE
P.E. NUMBER
DATE

KINGFIELD
ROUTE 16\27
PLANS

SHEET NUMBER
22
OF 175

Date: 4/13/2016

Username:

Division: HIGHWAY

Filename: ... \Austin\Highway\023_HDPlan17.dgn

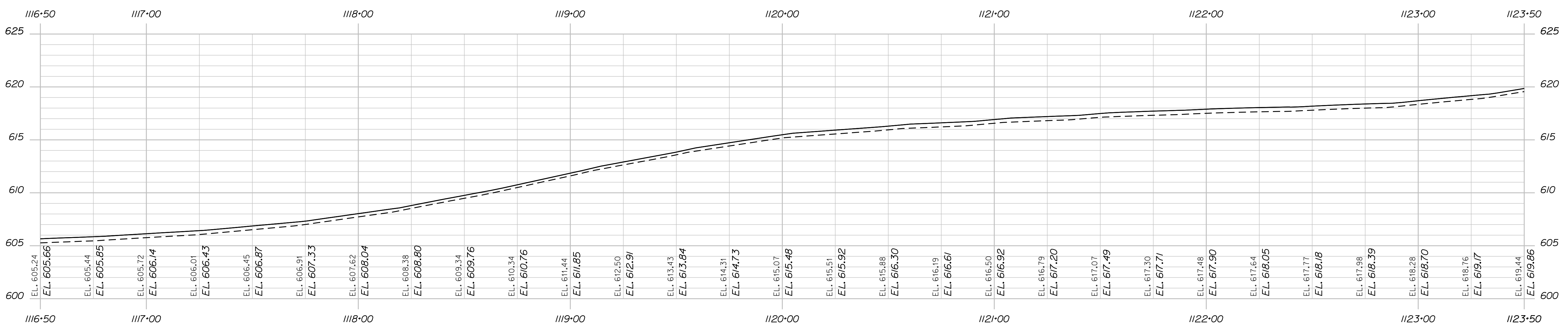
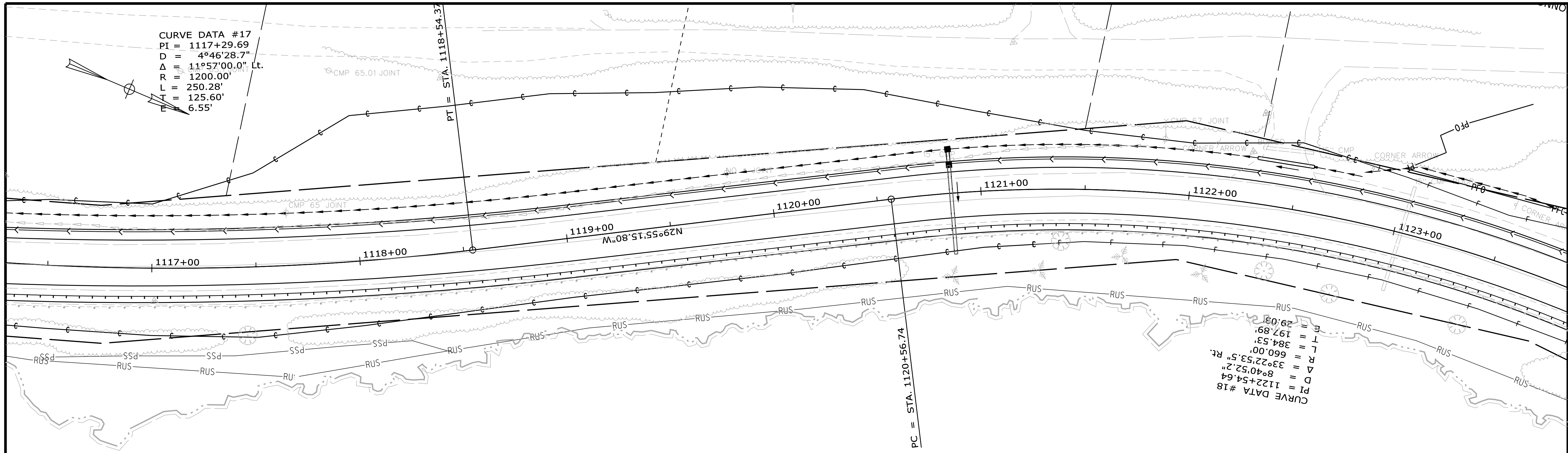

STATE OF MAINE
 DEPARTMENT OF TRANSPORTATION
 STP-1824(500)
 PIN 18245.00
 HIGHWAY PLANS

PROJ. MANAGER	PROJ. MANAGER'S	BY	DATE
DESIGN-DETAILED	DESIGNER'S	DATE	DATE
CHECKED-REVIEWED	DESIGNER'S	DATE	DATE
DESIGN-DETAILED	DESIGNER'S	DATE	DATE
REVISIONS 1	DESIGNER'S	DATE	DATE
REVISIONS 2	DESIGNER'S	DATE	DATE
REVISIONS 3	DESIGNER'S	DATE	DATE
REVISIONS 4	DESIGNER'S	DATE	DATE
FIELD CHANGES	DESIGNER'S	DATE	DATE

KINGFIELD
 ROUTE 16\27
 PLANS

SHEET NUMBER
 23
 OF 175

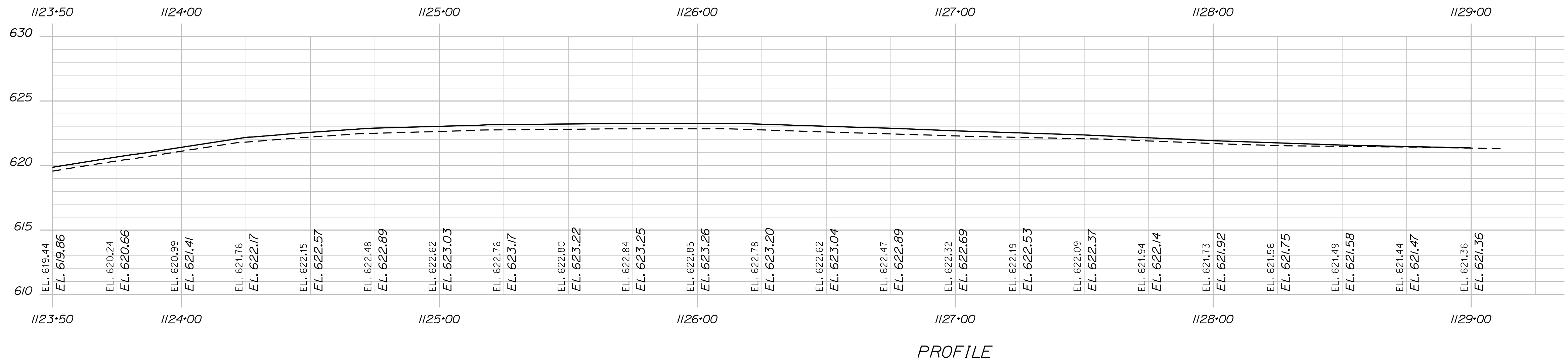
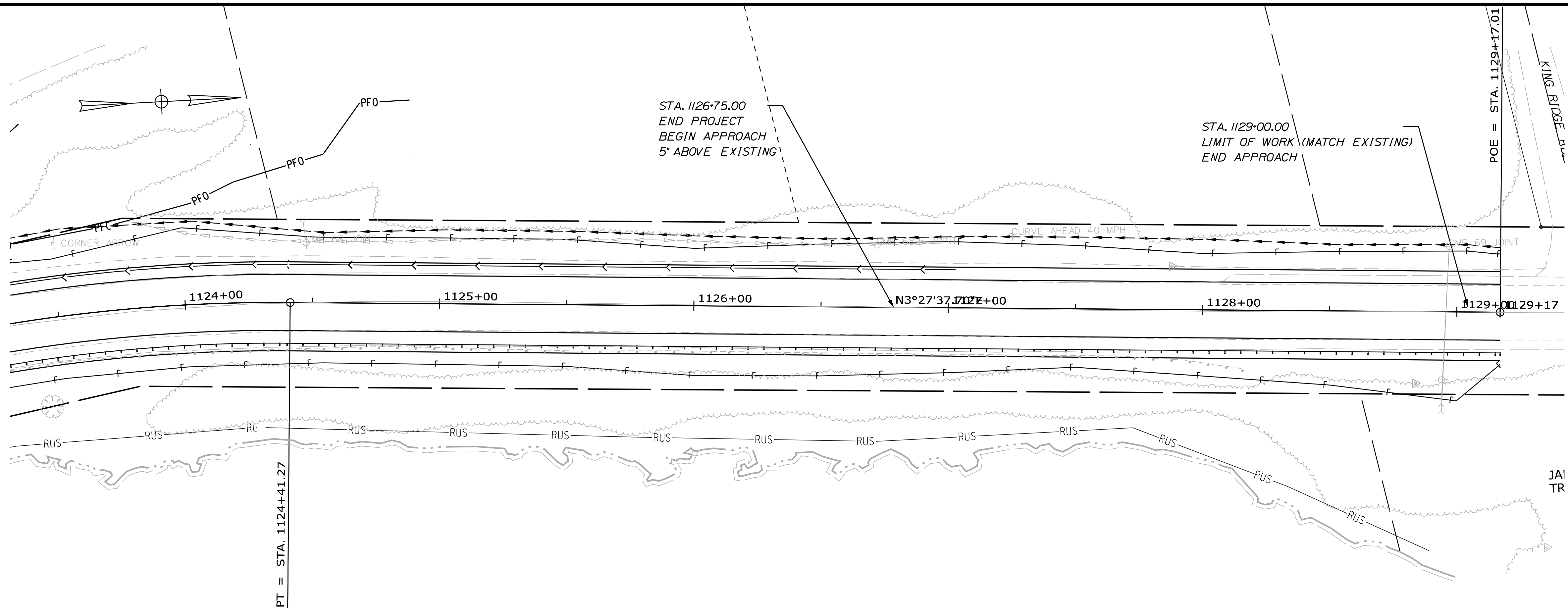

STATE OF MAINE
DEPARTMENT OF TRANSPORTATION
STP-1824(500)
PIN 18245.00
HIGHWAY PLANS

PROJ. MANAGER	PROJ. MANAGER'S	BY	DATE
DESIGN DETAILED	DESIGNER'S	DATE	DATE
CHECKED-REVIEWED	DESIGNER'S	DATE	DATE
DESIGN DETAILED	DESIGNER'S	DATE	DATE
DESIGN DETAILED	DESIGNER'S	DATE	DATE
REVISIONS 1	DESIGNER'S	DATE	DATE
REVISIONS 2	DESIGNER'S	DATE	DATE
REVISIONS 3	DESIGNER'S	DATE	DATE
REVISIONS 4	DESIGNER'S	DATE	DATE
FIELD CHANGES	DESIGNER'S	DATE	DATE

KINGFIELD
ROUTE 16\27
PLANS

SHEET NUMBER
24
OF 175

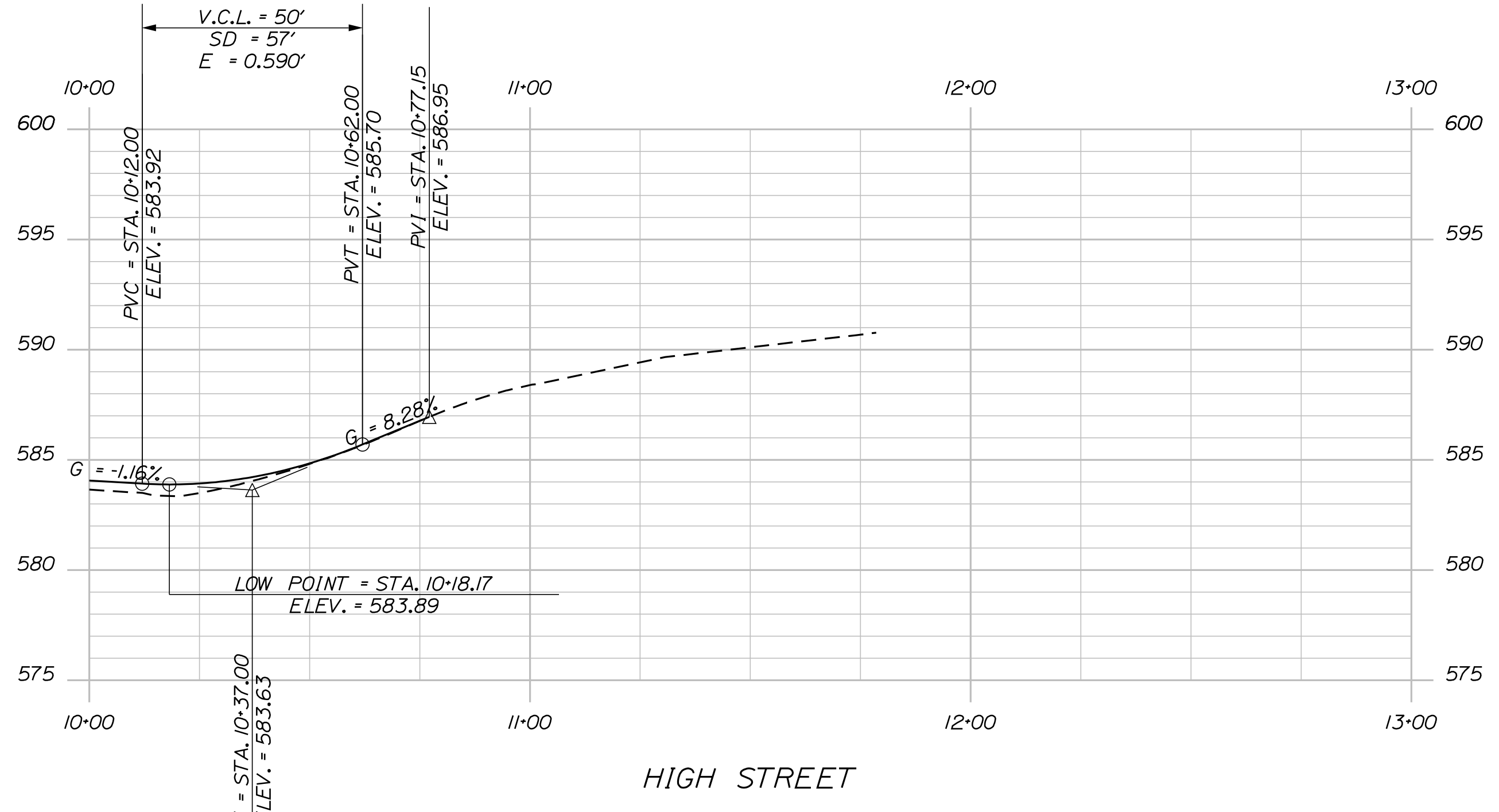
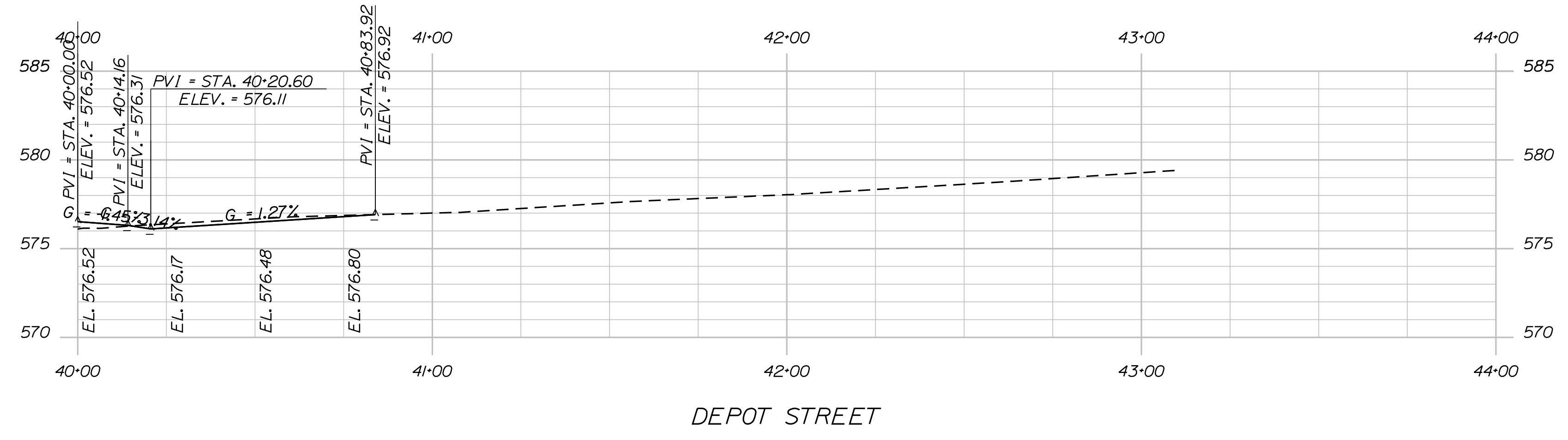

SHEET NUMBER

25

OF 175

KINGFIELD
ROUTE 16 \ 27
SIDE ROAD PROFILE

PROJ. MANAGER	DESIGNER	CHECKED	DATE
\$ProjectMgr1\$	\$Designer1\$	\$Checker1\$	\$Date1\$
\$ProjectMgr2\$	\$Designer2\$	\$Checker2\$	\$Date2\$
\$ProjectMgr3\$	\$Designer3\$	\$Checker3\$	\$Date3\$
\$ProjectMgr4\$	\$Designer4\$	\$Checker4\$	\$Date4\$
\$ProjectMgr5\$	\$Designer5\$	\$Checker5\$	\$Date5\$
\$ProjectMgr6\$	\$Designer6\$	\$Checker6\$	\$Date6\$

STATE OF MAINE
DEPARTMENT OF TRANSPORTATION
STP-1824(500)
PIN
PIN 18245.00
HIGHWAY PLANS

SIGNATURE
P.E. NUMBER
DATE

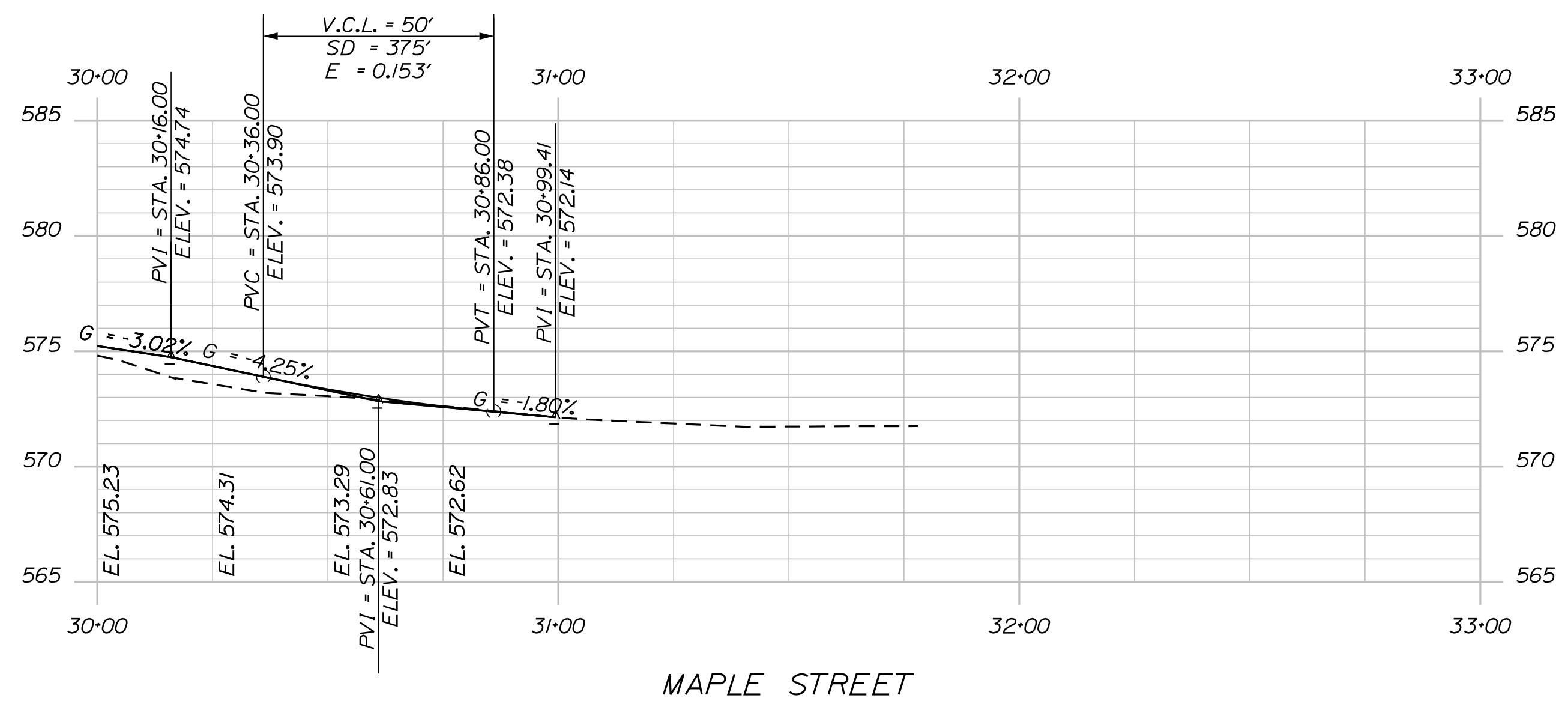
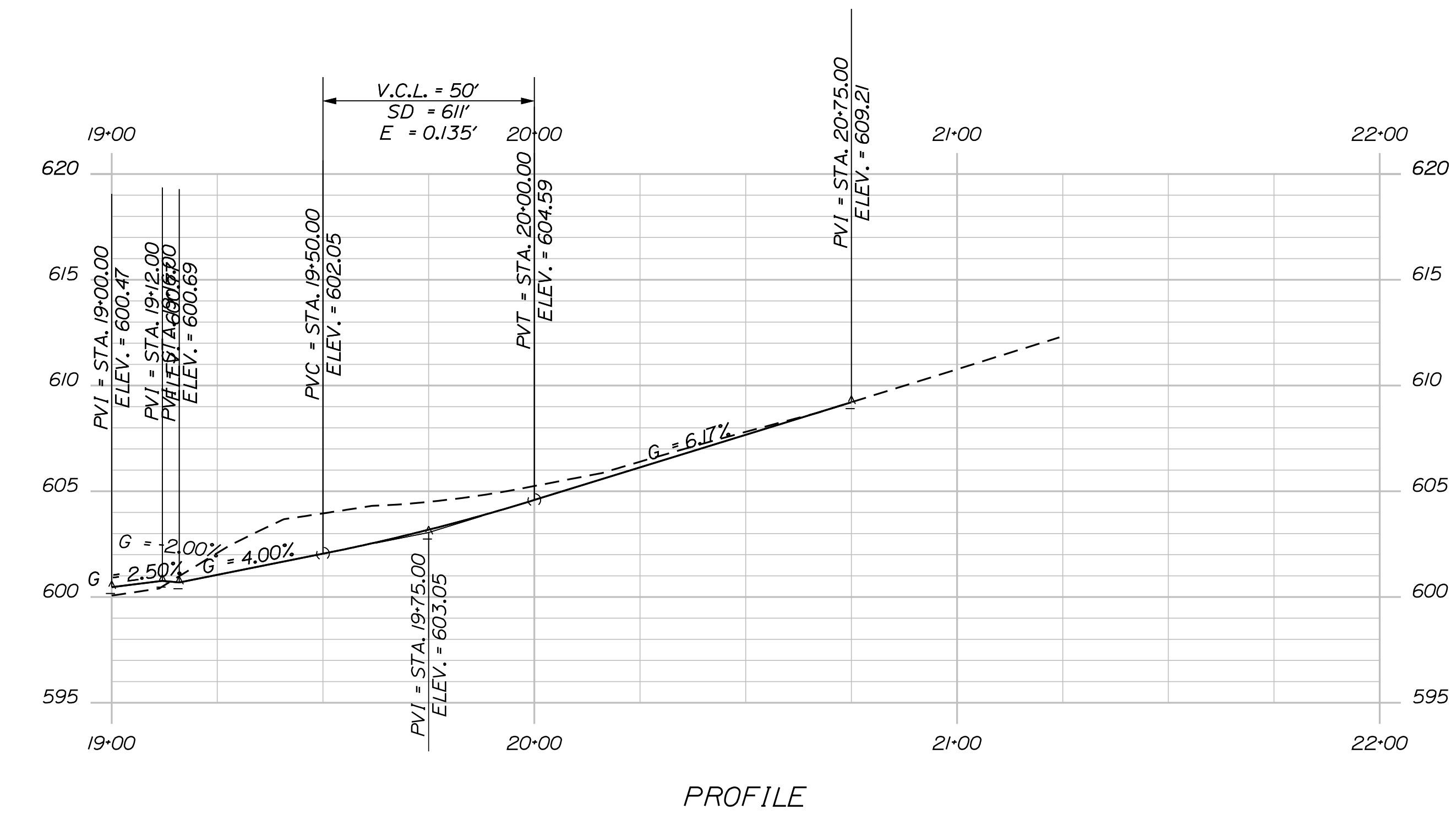

SHEET NUMBER

26

OF 175

KINGFIELD
ROUTE 16\27
SIDE ROAD PROFILE

PROJ. MANAGER	PROJ. MANAGER'S	BY	DATE
CHECKED-REVIEWED	DESIGNER'S	DATE	DATE
DESIGNS DETAILED	DESIGNER'S	DATE	DATE
REVISIONS 1	DESIGNER'S	DATE	DATE
REVISIONS 2	DESIGNER'S	DATE	DATE
REVISIONS 3	DESIGNER'S	DATE	DATE
REVISIONS 4	DESIGNER'S	DATE	DATE
FIELD CHANGES	FIELD CHANGES		

SIGNATURE
P.E. NUMBER
DATE

STATE OF MAINE
DEPARTMENT OF TRANSPORTATION
STP-1824(500)
PIN
PIN 18245.00
HIGHWAY PLANS

Date: \$date\$

Username:

Division: HIGHWAY

Filename: ... \Bentley\ustrn\Xsect.dgn

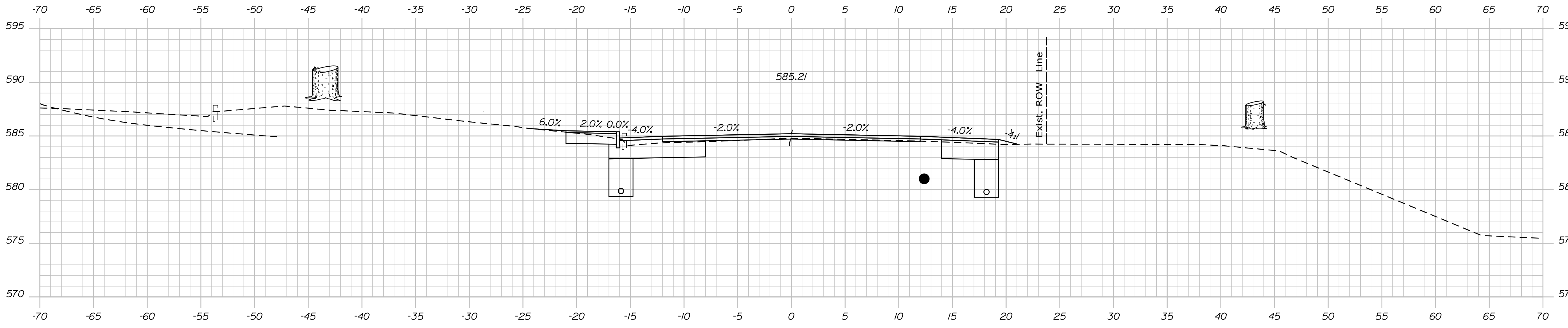

1006+50.00

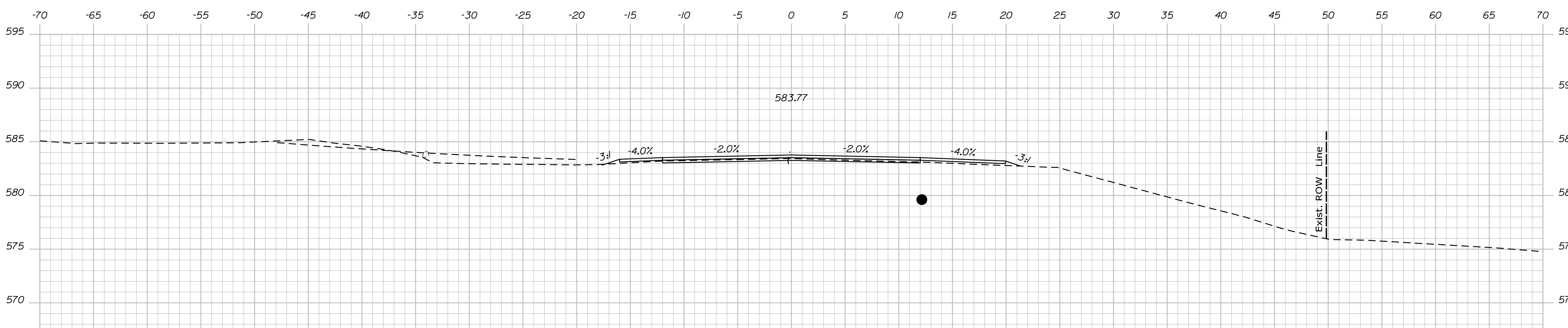

1006+00.00

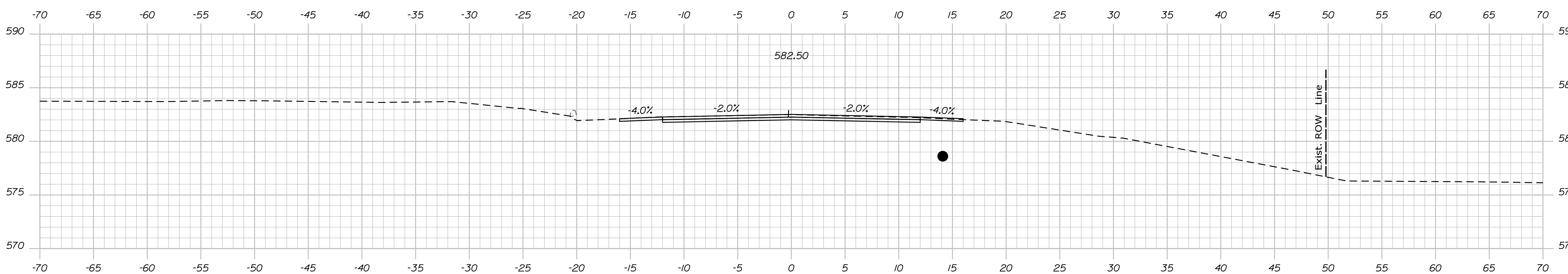

1005+50.00

STATE OF MAINE
DEPARTMENT OF TRANSPORTATION
STP-1824(500)
WIN
18245.00
HIERARCHIC PLANS

PROJ. MANAGER	DATE
CHECKED/REVIEWED	SIGNATURE
DESIGN DETAILER	P.E. NUMBER
DESIGN DETAILER	DATE
REVISIONS 1	
REVISIONS 2	
REVISIONS 3	
REVISIONS 4	
FIELD CHANGES	

PROJ. MANAGER	DATE
CHECKED/REVIEWED	SIGNATURE
DESIGN DETAILER	P.E. NUMBER
DESIGN DETAILER	DATE
REVISIONS 1	
REVISIONS 2	
REVISIONS 3	
REVISIONS 4	
FIELD CHANGES	

KINGFIELD
ROUTE 16\27
CROSS SECTIONS

SHEET NUMBER
Xse
OF 175

Date: \$date\$

Username:

Division: HIGHWAY

Filename: ... \Bentley\ustrn\Xsect.dgn

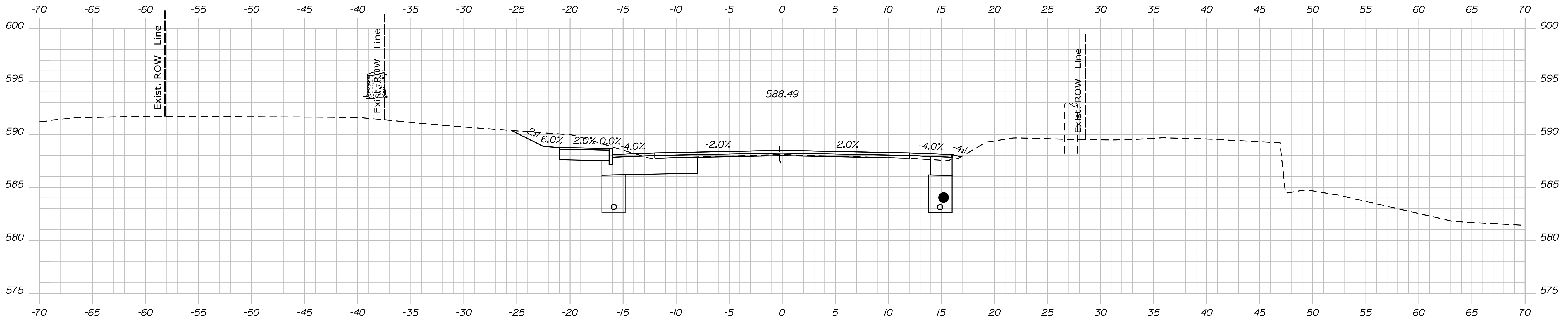

1007+50.00

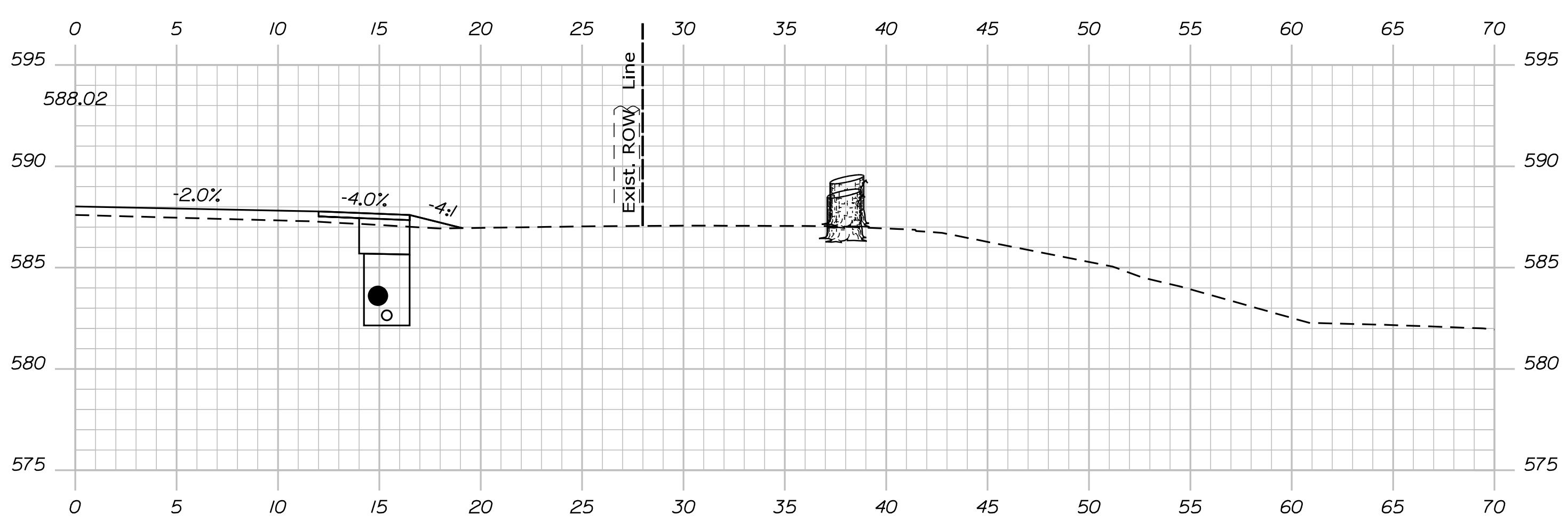

1007+35.00

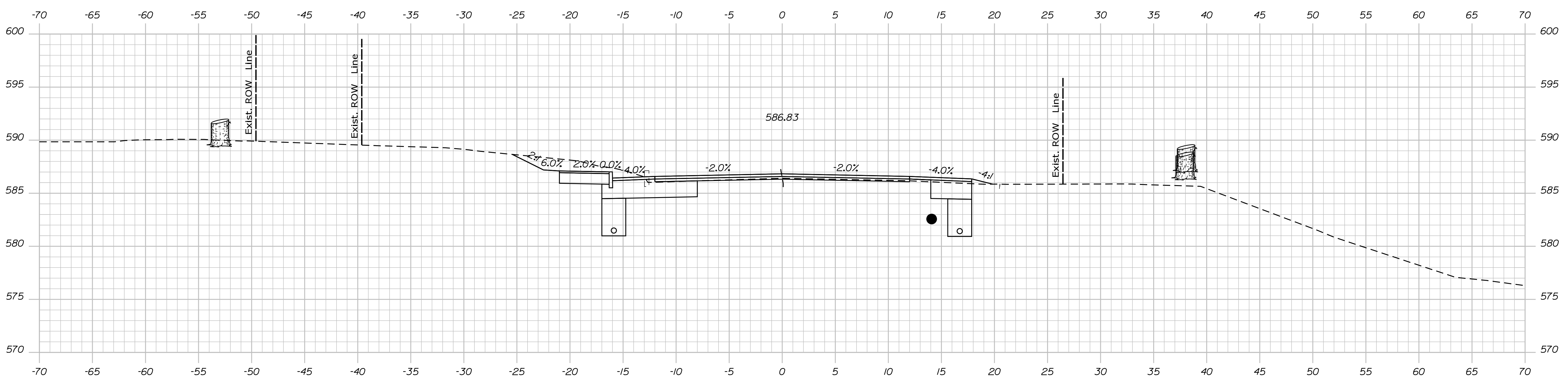

1007+00.00

STATE OF MAINE
DEPARTMENT OF TRANSPORTATION
STP-1824(500)
WIN
18245.00
HIERARCHIC PLANS

SIGNATURE
P.E. NUMBER
DATE

PROJ. MANAGER	DATE
DESIGN DETAIL	
CHECKED/REVIEWED	
DESIGN DETAIL	
DESIGN DETAIL	
REVISIONS 1	
REVISIONS 2	
REVISIONS 3	
REVISIONS 4	
FIELD CHANGES	

KINGFIELD
ROUTE 16\27
CROSS SECTIONS

SHEET NUMBER
Xse
OF 175

Filename: ... \Bentley\ustrn\Xsect.dgn

Division: HIGHWAY

Username:

Date: \$date\$

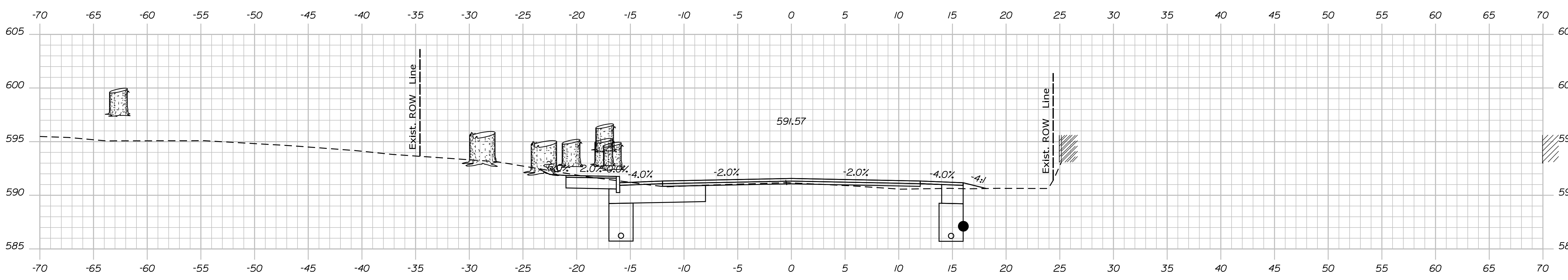

1009+00.00

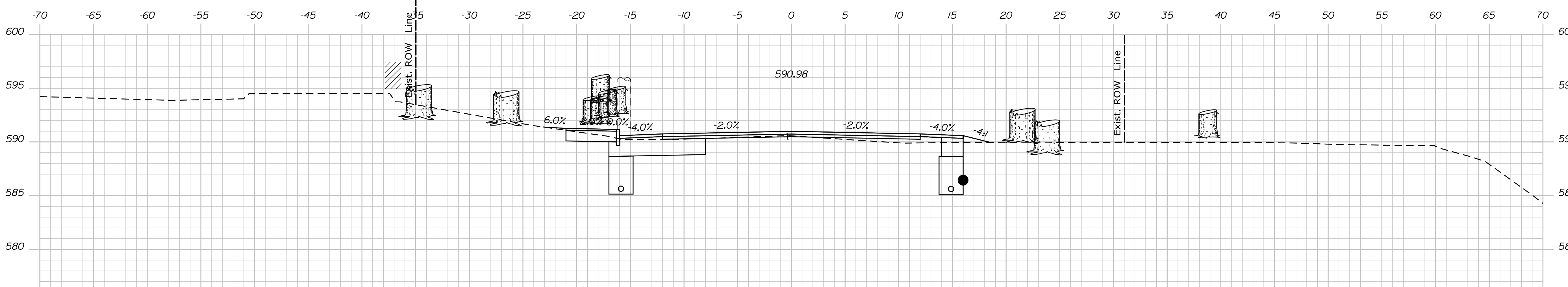

1008+50.00

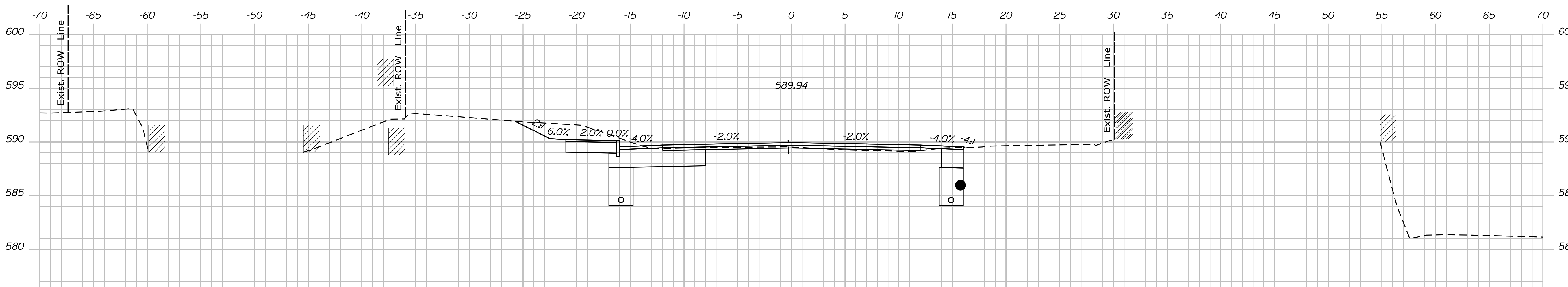

1008+00.00

STATE OF MAINE
DEPARTMENT OF TRANSPORTATION
STP-1824(500)
WIN
18245.00
HIGHWAY PLANS

PROJ. MANAGER \$PROJMANAGER\$
DESIGN DETAILED
CHECKED/REVIEWED
DESIGN DETAILED
DESIGN DETAILED
REVISIONS 1
REVISIONS 2
REVISIONS 3
REVISIONS 4
FIELD CHANGES

DATE	BY	SIGNATURE	P.E. NUMBER	DATE

KINGFIELD
ROUTE 16\27
CROSS SECTIONS

SHEET NUMBER
Xse
OF 175

Date: \$date\$

Username:

Division: HIGHWAY

Filename: ... \Bentley\ustrn\Xsect.dgn

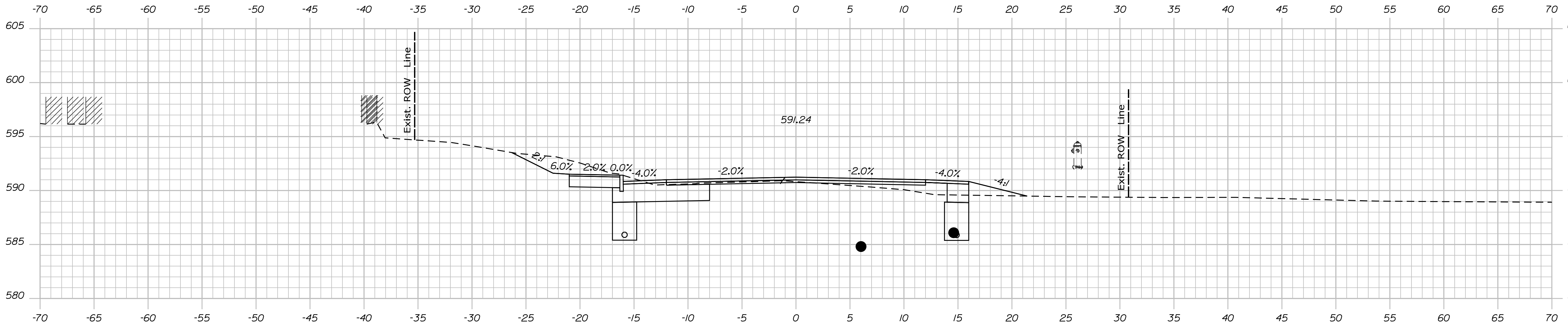

1010+00.00

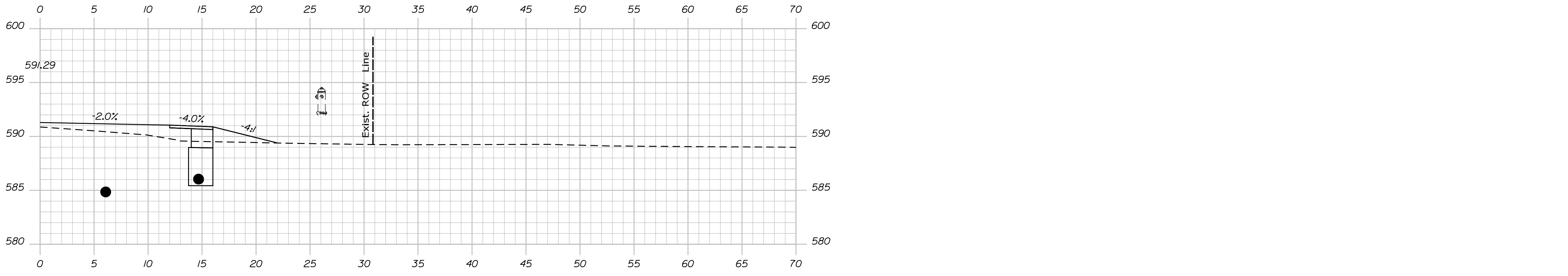

1009+96.00

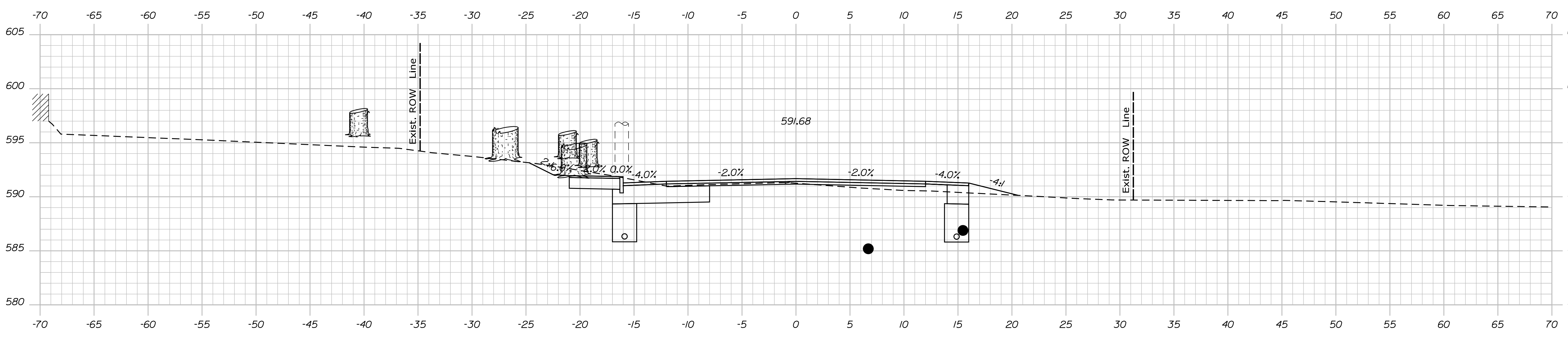

1009+50.00

STATE OF MAINE
DEPARTMENT OF TRANSPORTATION
STP-1824(500)
WIN
18245.00
HIGHWAY PLANS

DESIGN/DETAILED	SIGNATURE
CHECKED/REVIEWED	P.E. NUMBER
DESIGN DET AILED	DATE
DESIGN DET AILED	
REVISIONS 1	
REVISIONS 2	
REVISIONS 3	
REVISIONS 4	
FIELD CHANGES	

PROJ. MANAGER	BY	DATE
\$PROJMANAGER\$		

KINGFIELD
ROUTE 16\27
CROSS SECTIONS

SHEET NUMBER
Xse
OF 175

Date: \$date\$

Username:

Division: HIGHWAY

Filename: ... \Bentley\ustrn\Xsect.dgn

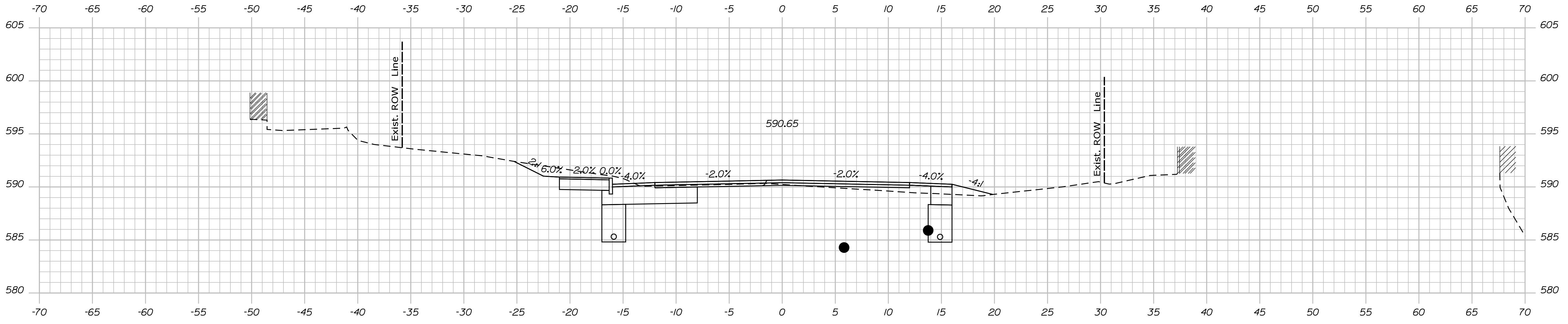

1010+50.00

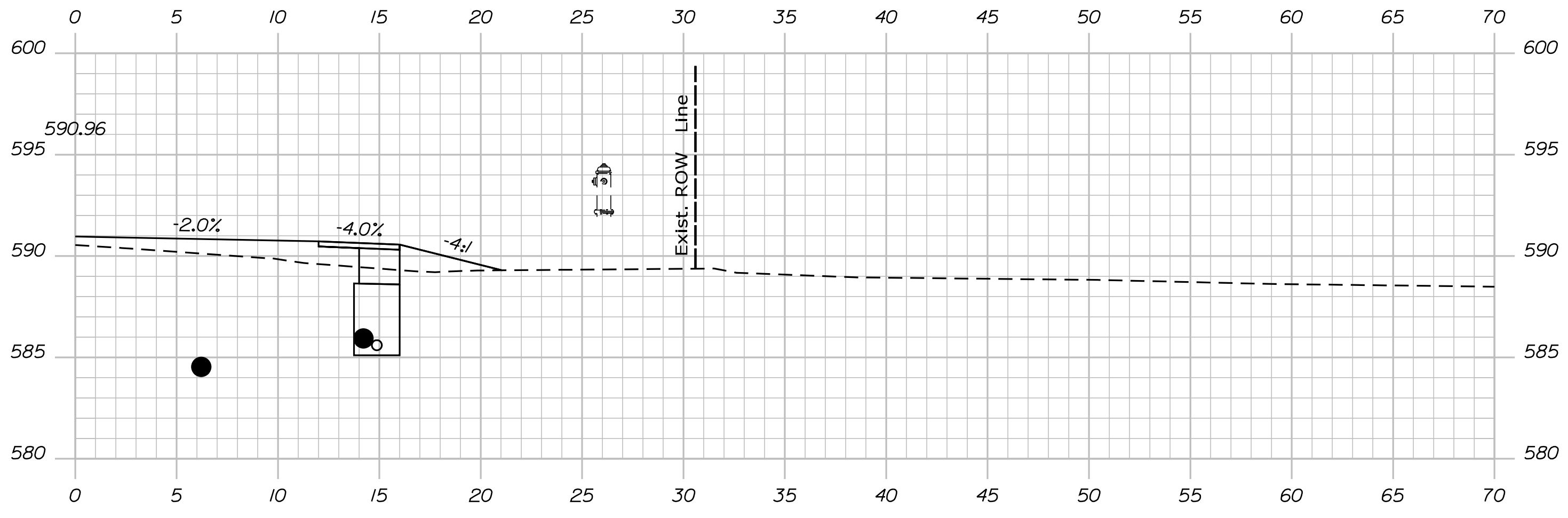

1010+23.00

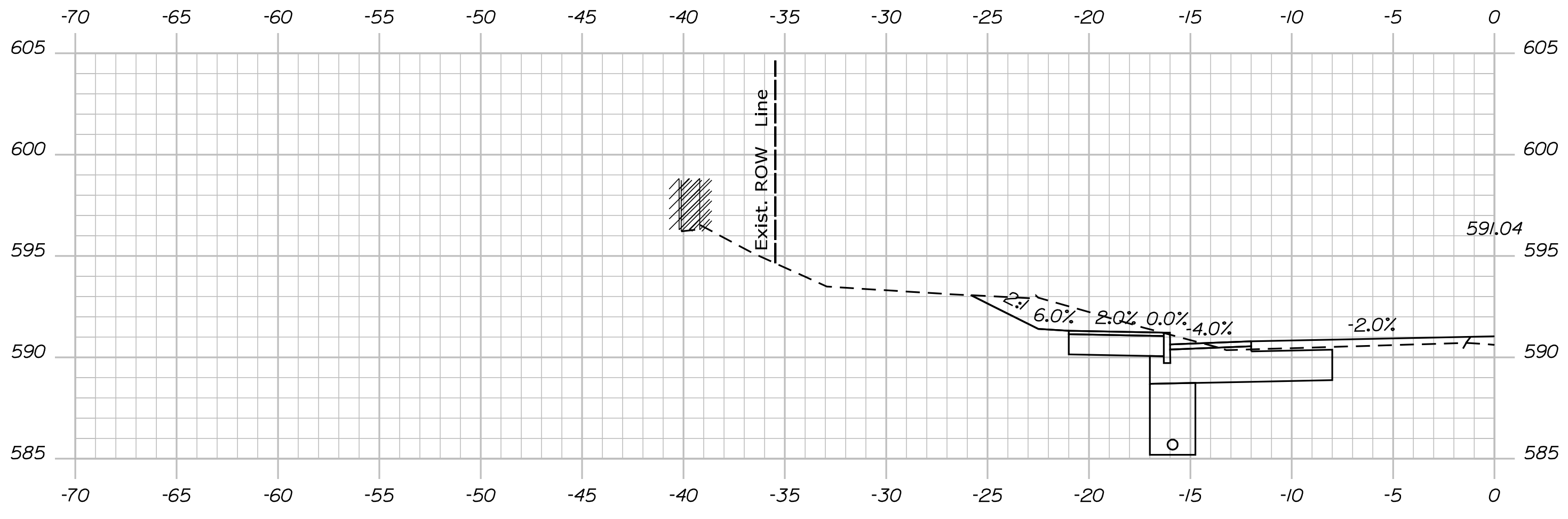

1010+16.00

STATE OF MAINE
DEPARTMENT OF TRANSPORTATION
STP-1824(500)
WIN
18245.00
HIERARCHIC PLANS

SIGNATURE
P.E. NUMBER
DATE

PROJ. MANAGER	BY	DATE
DESIGN DETAILER		
CHECKED/REVIEWED		
DESIGN DETAILER		
DESIGN DETAILER		
REVISIONS 1		
REVISIONS 2		
REVISIONS 3		
REVISIONS 4		
FIELD CHANGES		

KINGFIELD
ROUTE 16\27
CROSS SECTIONS

SHEET NUMBER
Xse
OF 175

Date: \$date\$

Username:

Division: HIGHWAY

Filename: ... \Bentley\ustrn\Xsect.dgn

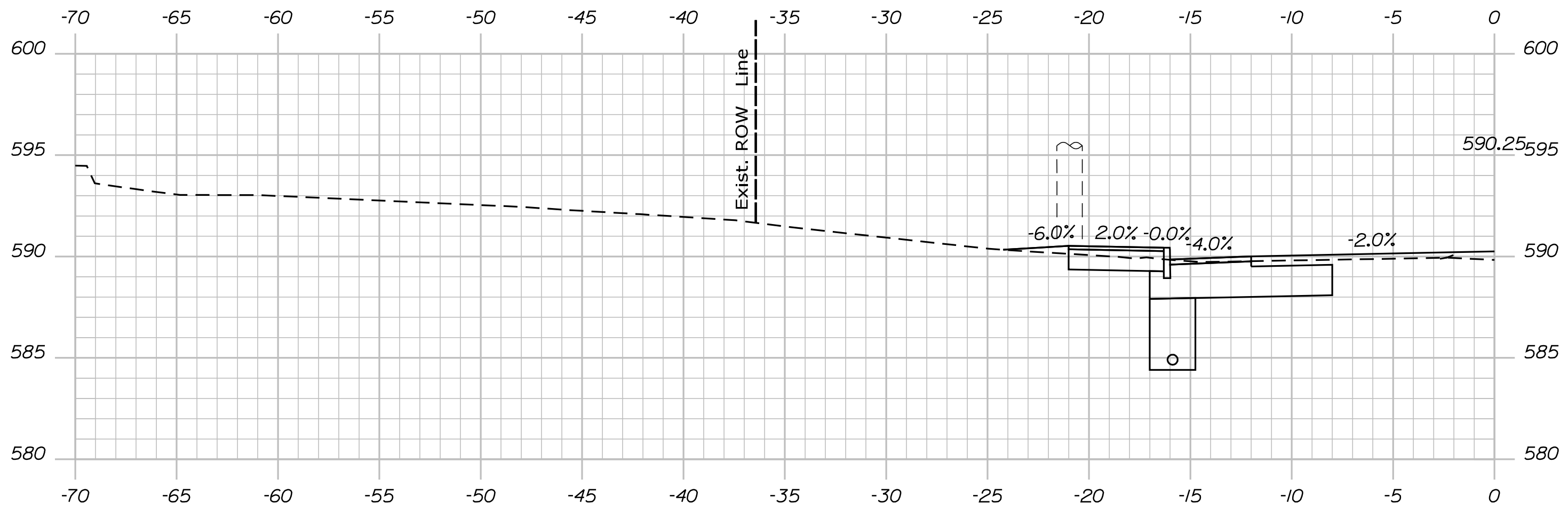

1011+13.00

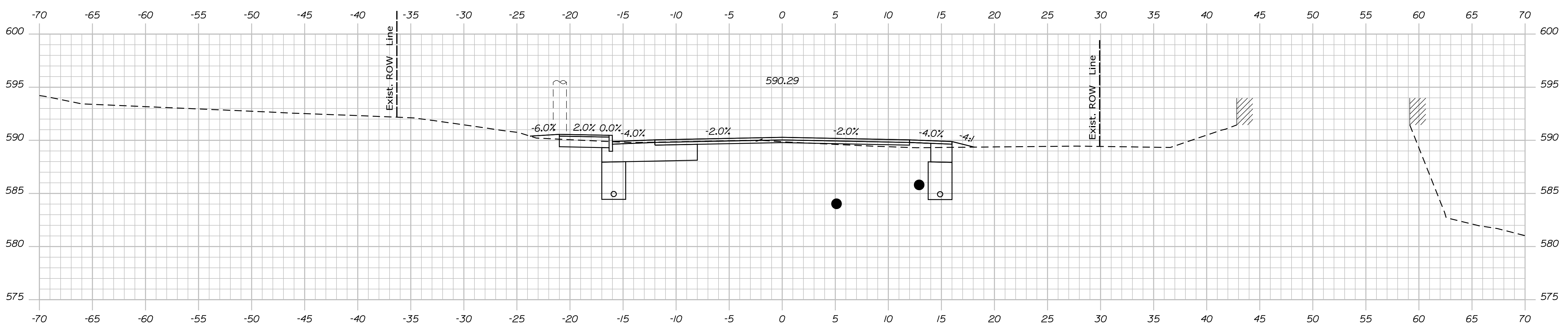

1011+00.00

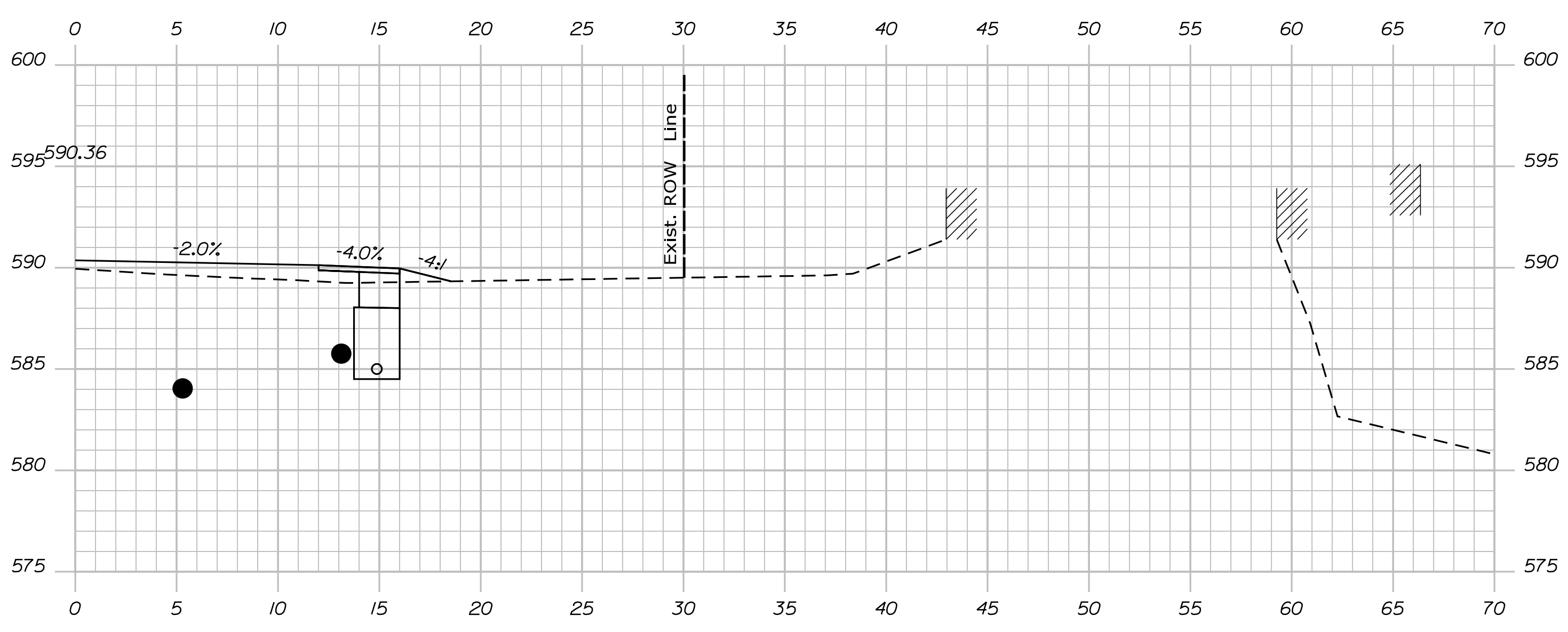

1010+87.00

STATE OF MAINE
DEPARTMENT OF TRANSPORTATION
STP-1824(500)
WIN
18245.00
HIERARCHIC PLANS

SIGNATURE
P.E. NUMBER
DATE

PROJ. MANAGER	DATE
DESIGN DETAILED	
CHECKED/REVIEWED	
DESIGN DETAILED	
DESIGN DETAILED	
REVISIONS 1	
REVISIONS 2	
REVISIONS 3	
REVISIONS 4	
FIELD CHANGES	

KINGFIELD
ROUTE 16\27
CROSS SECTIONS

SHEET NUMBER
Xse
OF 175

Date: \$date\$

Username:

Division: HIGHWAY

Filename: ... \Bentley\ustrn\Xsect.dgn

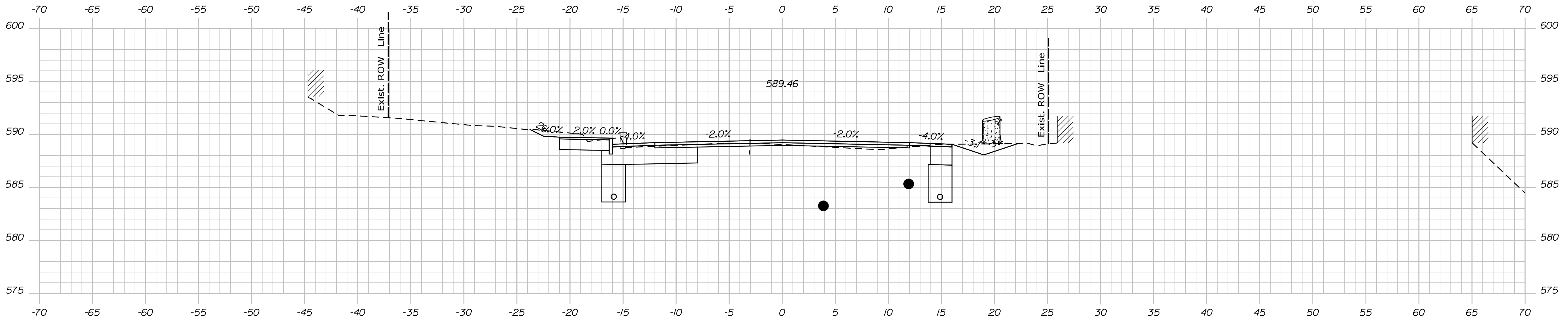

1012+00.00

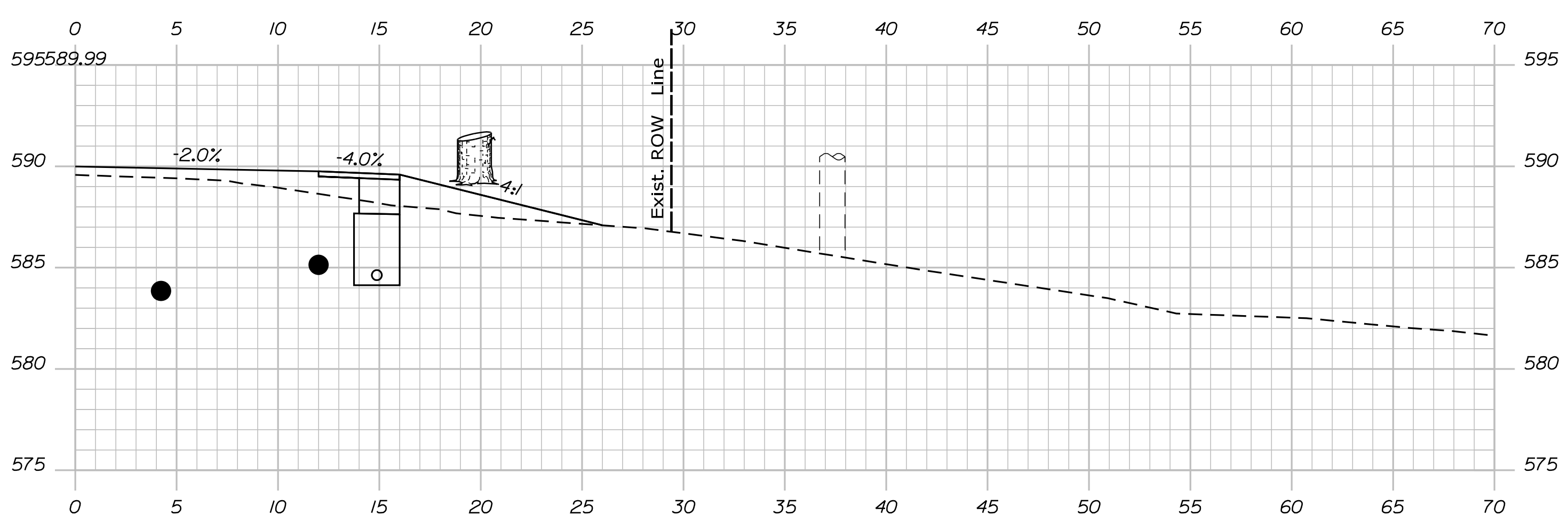

1011+69.00

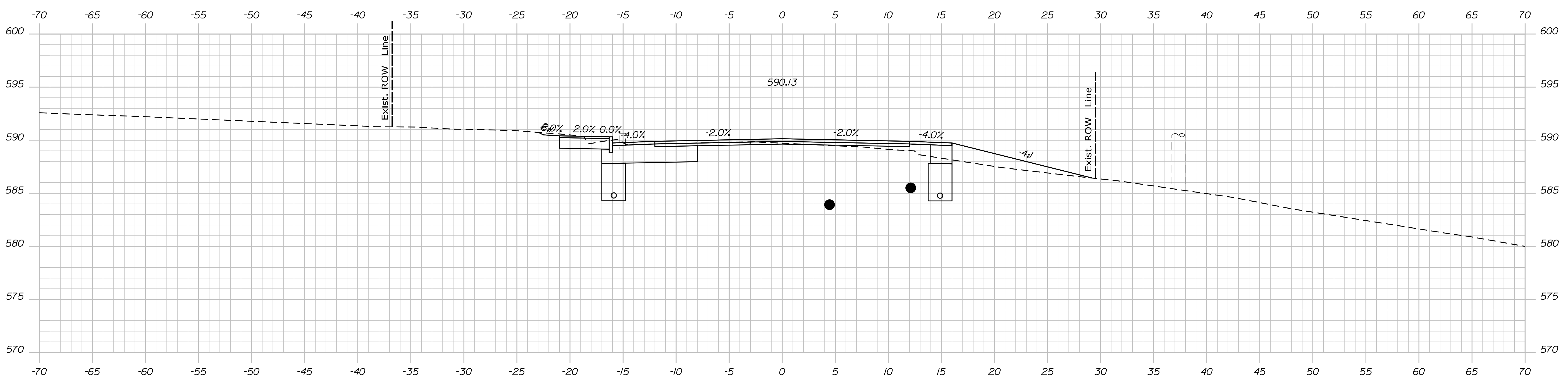

1011+50.00

STATE OF MAINE
DEPARTMENT OF TRANSPORTATION
STP-1824(500)
WIN
18245.00
HIERARCHIC PLANS

PROJ. MANAGER	DATE	BY	DATE
DESIGN/DETAILED			
CHECKED/REVIEWED			
DESIGNED/PALEDD			
DESIGNED/PALEDD			
REVISIONS 1			
REVISIONS 2			
REVISIONS 3			
REVISIONS 4			
FIELD CHANGES			

KINGFIELD
ROUTE 16\27
CROSS SECTIONS

SHEET NUMBER
Xse
OF 175

Date: \$date\$

Username:

Division: HIGHWAY

Filename: ... \Bentley\ustrn\Xsect.dgn

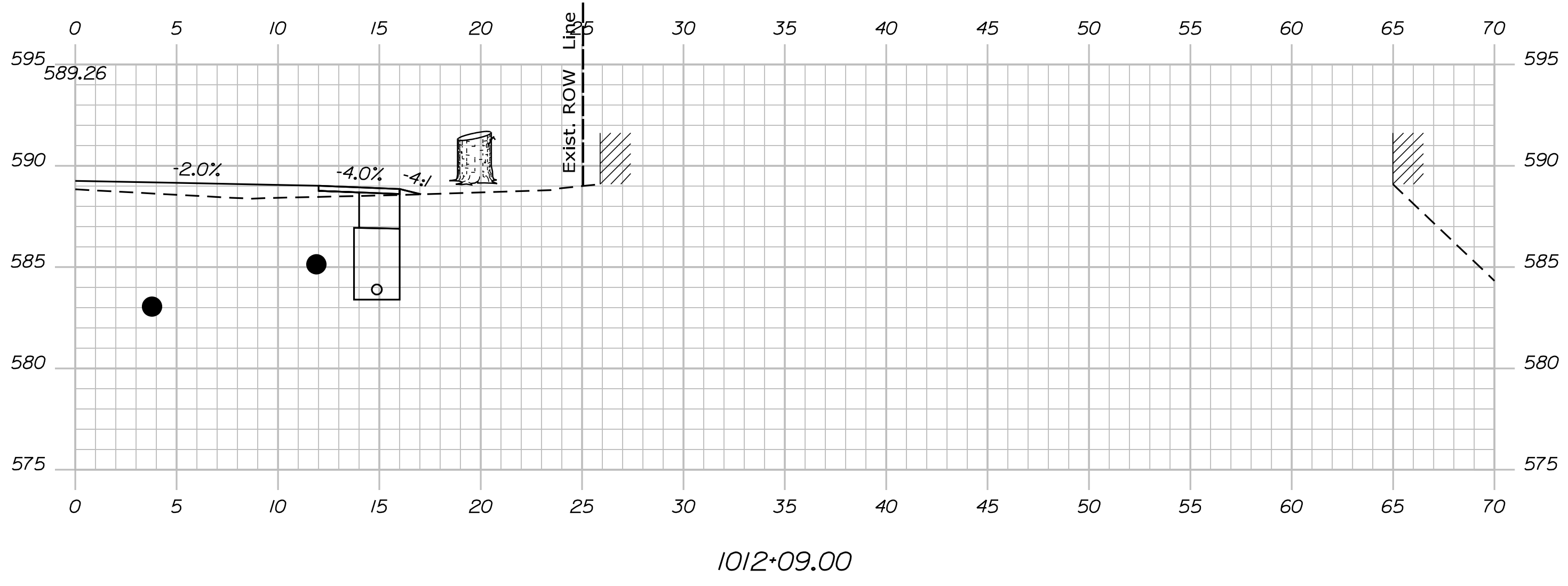
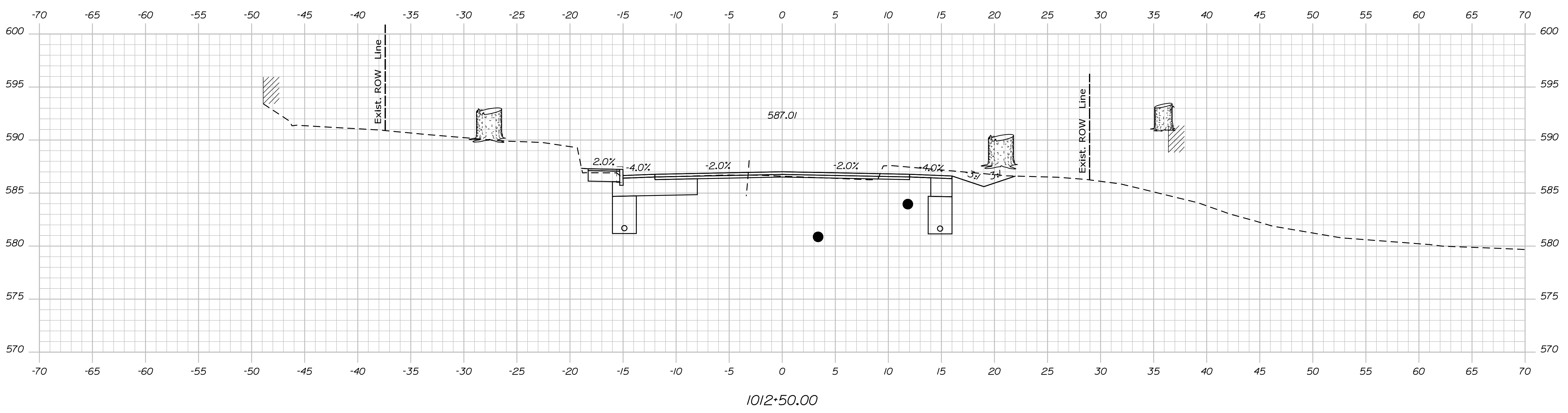
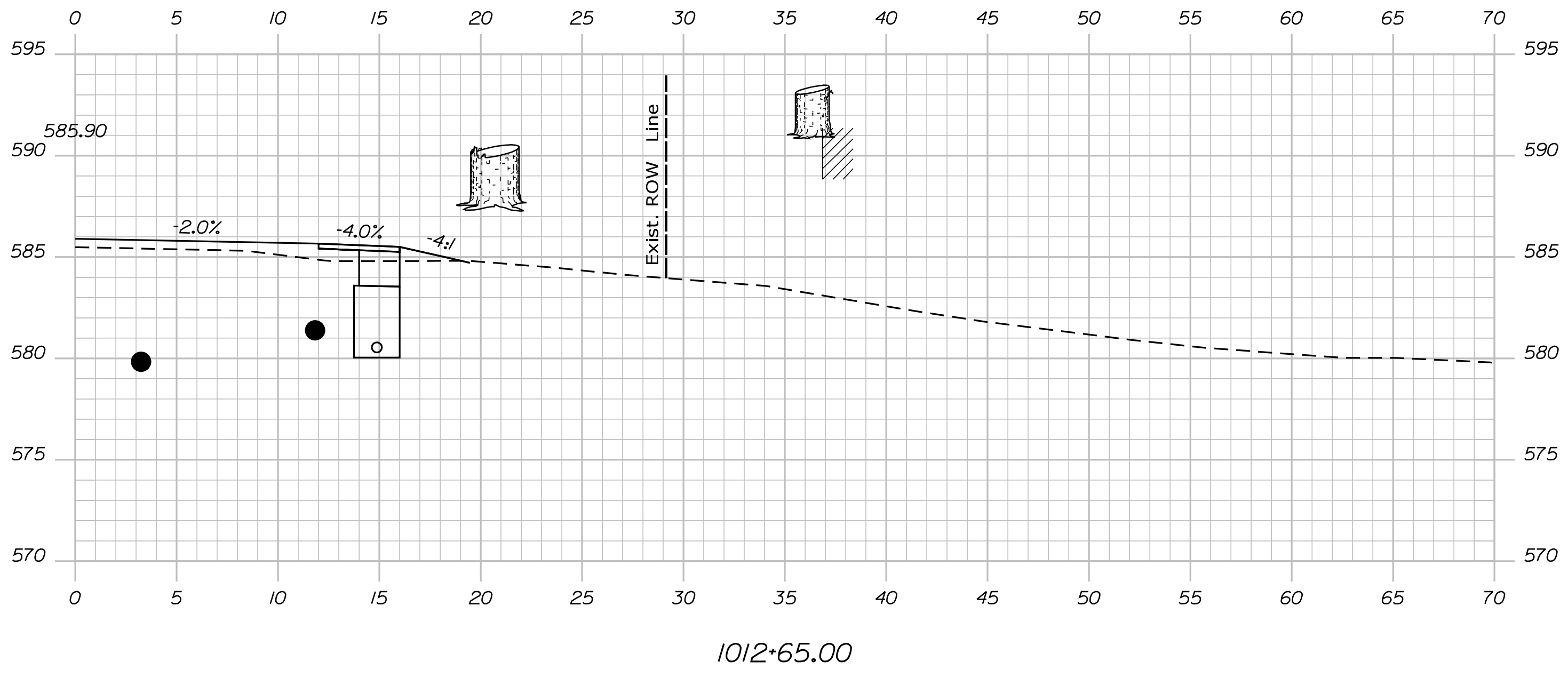

STATE OF MAINE
DEPARTMENT OF TRANSPORTATION
STP-1824(500)
WIN
18245.00
HIERARCHIC PLANS

SIGNATURE
P.E. NUMBER
DATE

PROJ. MANAGER	DATE	BY
DESIGN DETAILER		
CHECKED/REVIEWER		
DESIGN DETAILER		
DESIGN DETAILER		
REVISIONS 1		
REVISIONS 2		
REVISIONS 3		
REVISIONS 4		
FIELD CHANGES		

KINGFIELD
ROUTE 16\27

CROSS SECTIONS

SHEET NUMBER

Xse

OF 175

Date: \$date\$

Username:

Division: HIGHWAY

Filename: ... \Bentley\ustrn\Xsect.dgn

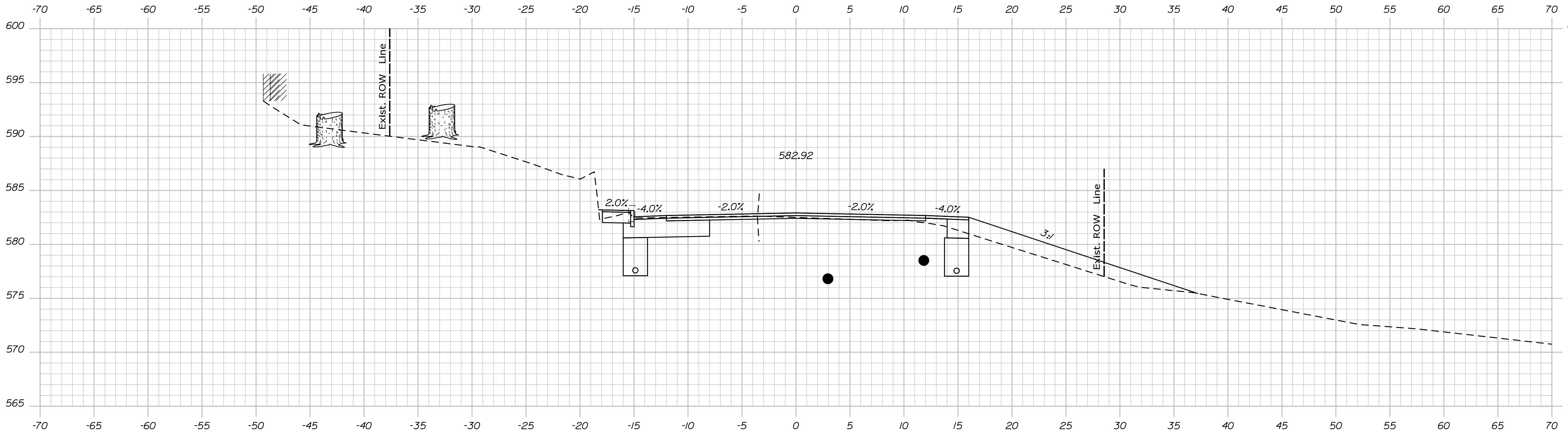

1013+00.00

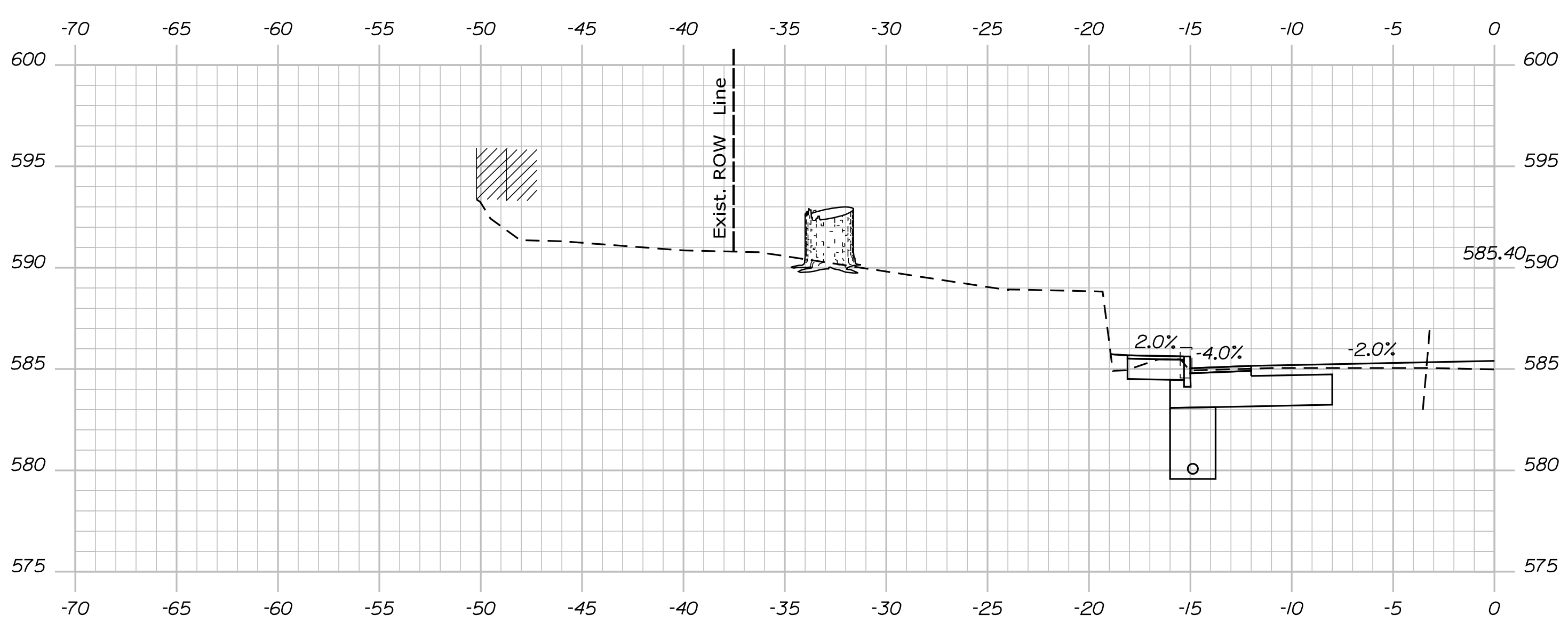

1012+71.00

STATE OF MAINE
 DEPARTMENT OF TRANSPORTATION
STP-1824(500)
 WIN
 18245.00
 HIGHWAY PLANS

SIGNATURE
 P.E. NUMBER
 DATE

PROJ. MANAGER	DATE
DESIGN DETAILER	
CHECKED/REVIEWED	
DESIGN DETAILER	
DESIGN DETAILER	
REVISIONS 1	
REVISIONS 2	
REVISIONS 3	
REVISIONS 4	
FIELD CHANGES	

KINGFIELD
 ROUTE 16\27
 CROSS SECTIONS

SHEET NUMBER
Xse
 OF 175

Date: \$date\$

Username:

Division: HIGHWAY

Filename: ... \Bentley\ustrn\Xsect.dgn

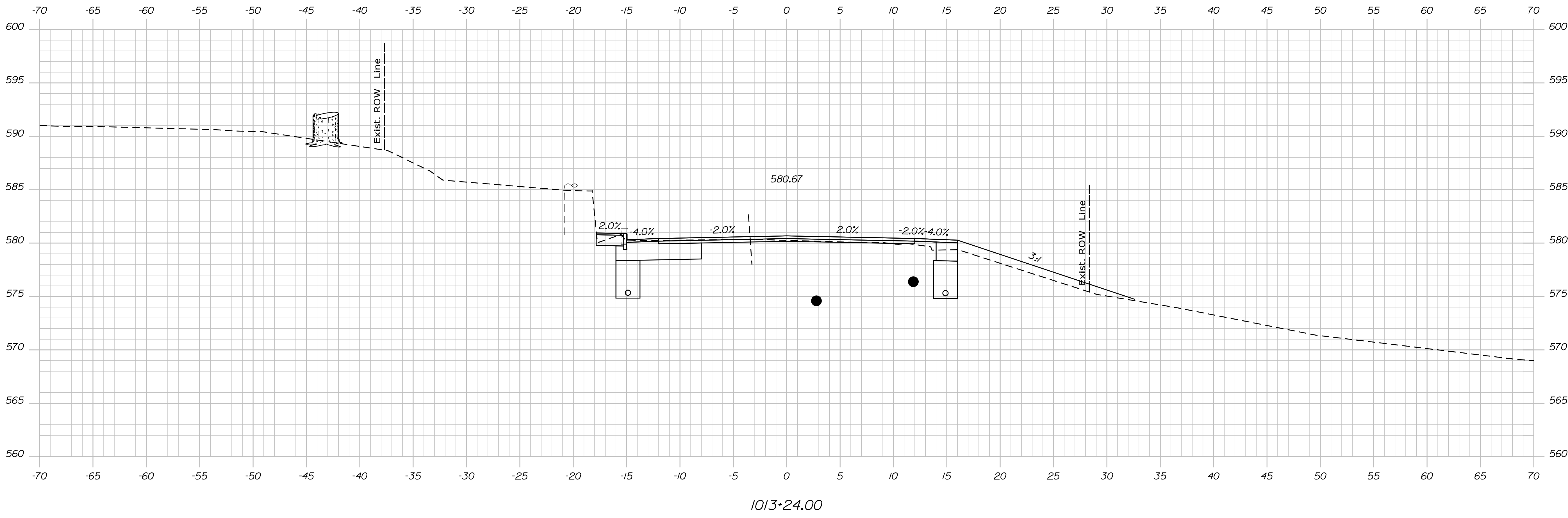
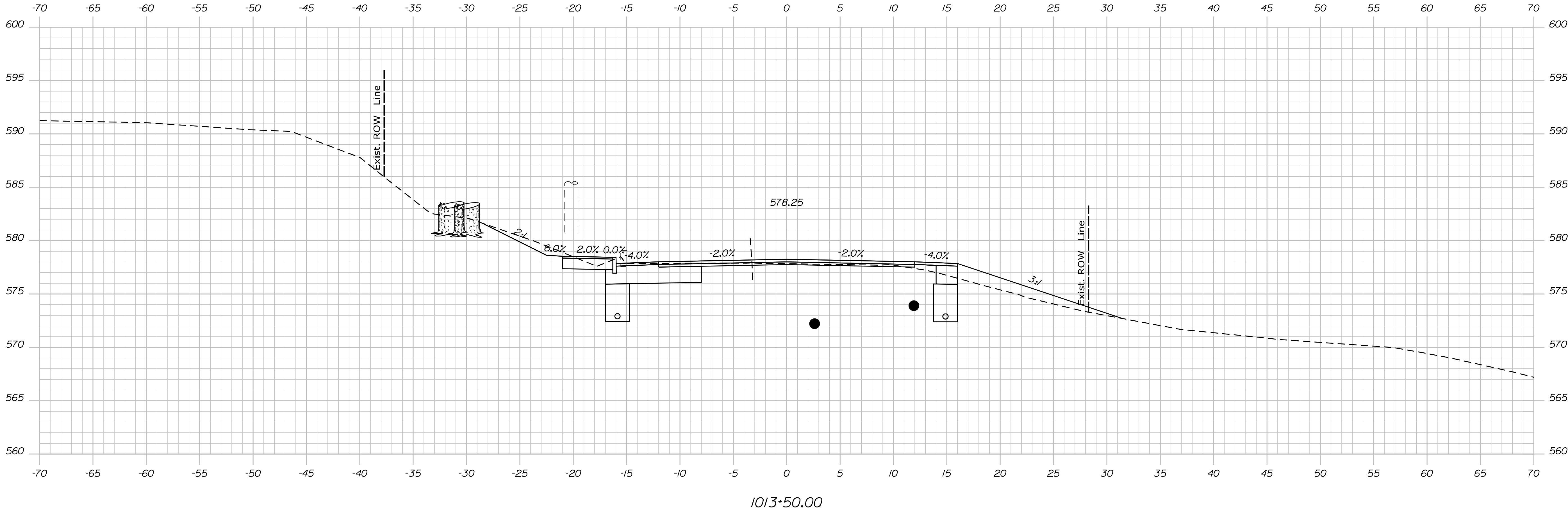

STATE OF MAINE
 DEPARTMENT OF TRANSPORTATION
 STP-1824(500)
 WIN
 18245.00
 HIGHWAY PLANS

SIGNATURE
 P.E. NUMBER
 DATE

PROJ. MANAGER	DATE
DESIGN DETAIL	
CHECKED/REVIEWED	
DESIGN DETAIL	
DESIGN DETAIL	
REVISIONS 1	
REVISIONS 2	
REVISIONS 3	
REVISIONS 4	
FIELD CHANGES	

KINGFIELD
 ROUTE 16\27
 CROSS SECTIONS

SHEET NUMBER
 Xse
 OF 175

Sta. 1013+24.00 to Sta. 1013+50.00

Date: \$date\$

Username:

Division: HIGHWAY

Filename: ... \Bentley\ustrn\Xsect.dgn

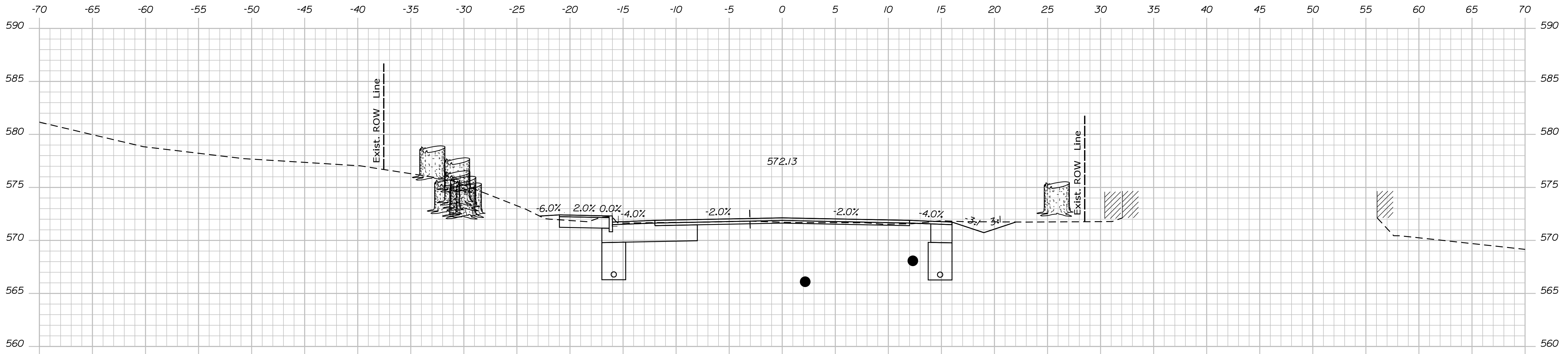

1014+50.00

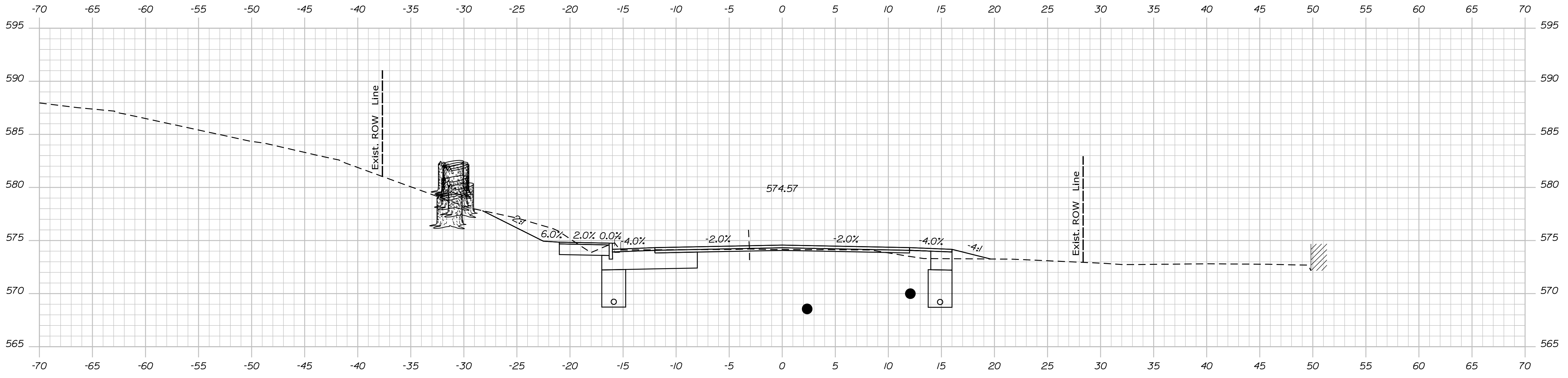

1014+00.00

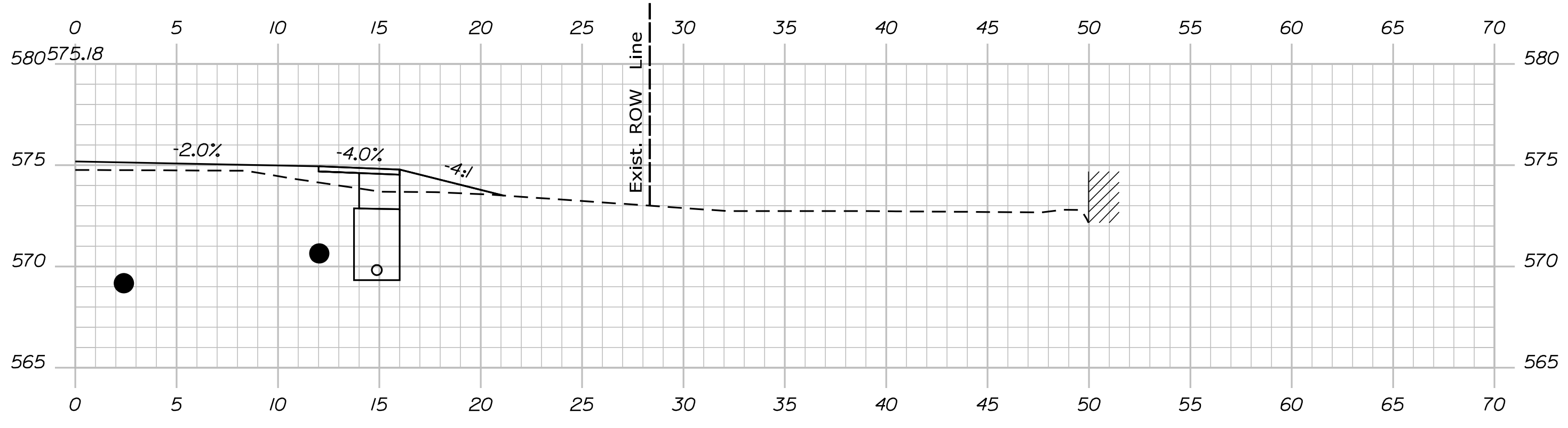

1013+90.00

STATE OF MAINE
DEPARTMENT OF TRANSPORTATION
STP-1824(500)
WIN
18245.00
HIGHWAY PLANS

DESIGN DETAIL	SIGNATURE
CHECKED/REVIEWED	P.E. NUMBER
DESIGN DETAIL	DATE
DESIGN DETAIL	
REVISIONS 1	
REVISIONS 2	
REVISIONS 3	
REVISIONS 4	
FIELD CHANGES	

PROJ. MANAGER	DATE
BY	
DESIGN DETAIL	
CHECKED/REVIEWED	
DESIGN DETAIL	
DESIGN DETAIL	
REVISIONS 1	
REVISIONS 2	
REVISIONS 3	
REVISIONS 4	
FIELD CHANGES	

KINGFIELD
ROUTE 16\27
CROSS SECTIONS

SHEET NUMBER
Xse
OF 175

Date: \$date\$

Username:

Division: HIGHWAY

Filename: ... \Bentley\ustrn\Xsect.dgn

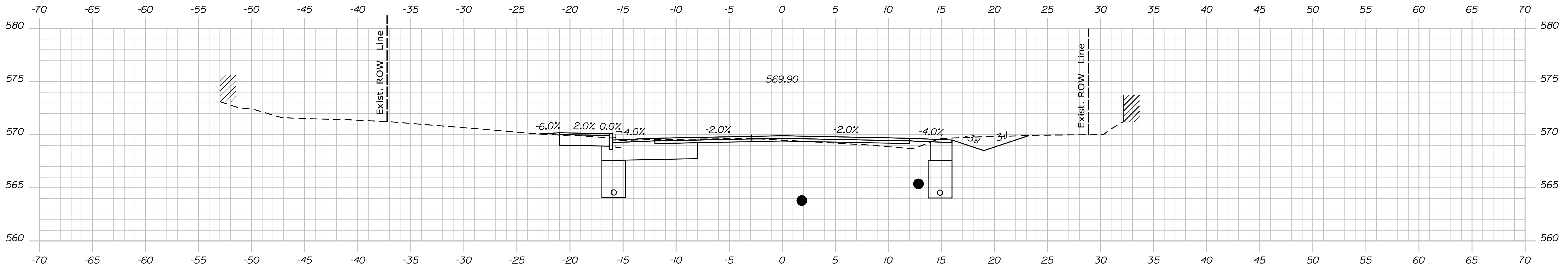

1015+50.00

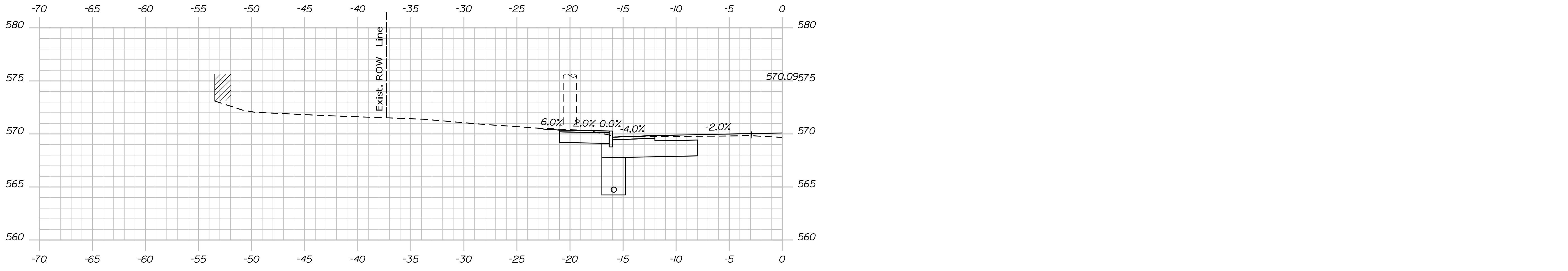

1015+36.00

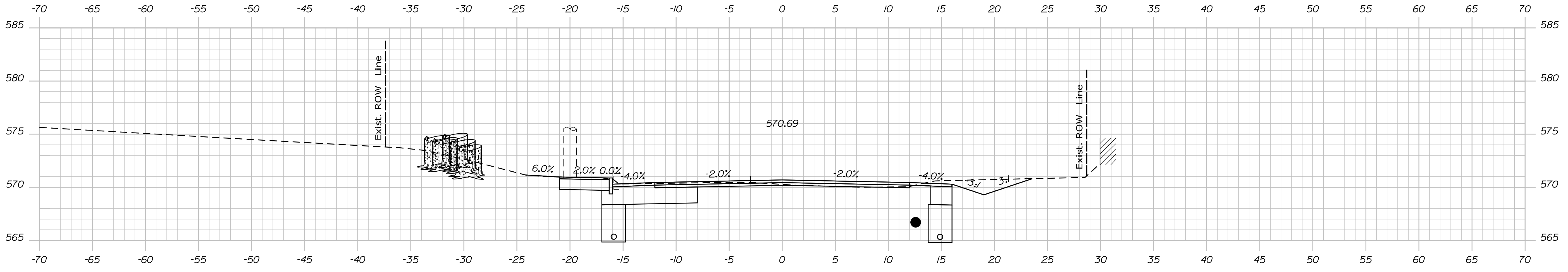

1015+00.00

STATE OF MAINE
DEPARTMENT OF TRANSPORTATION
STP-1824(500)
WIN
18245.00
HIERARCHIC PLANS

SIGNATURE
P.E. NUMBER
DATE

PROJ. MANAGER	DATE
DESIGN/DETAILED	
CHECKED/REVIEWED	
DESIGN/DETAILED	
DESIGN/DETAILED	
REVISIONS 1	
REVISIONS 2	
REVISIONS 3	
REVISIONS 4	
FIELD CHANGES	

KINGFIELD
ROUTE 16\27
CROSS SECTIONS

SHEET NUMBER
Xse
OF 175

Date: \$date\$

Username:

Division: HIGHWAY

Filename: ... \Bentley\ustrn\Xsect.dgn

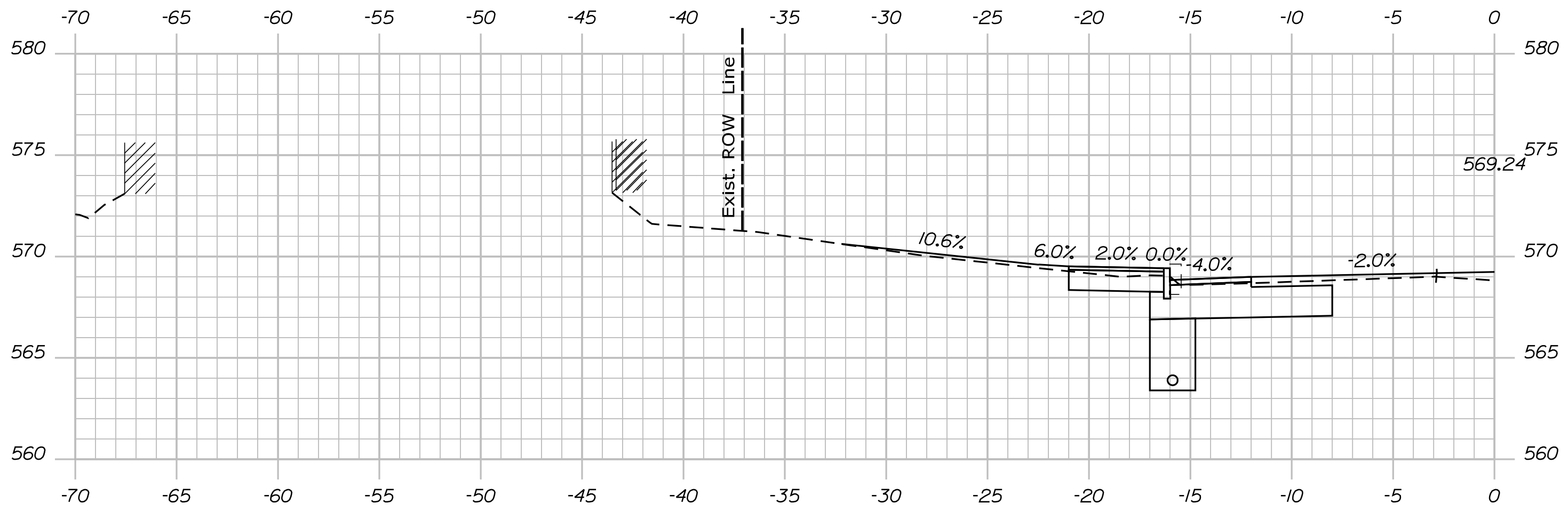

1015+94.00

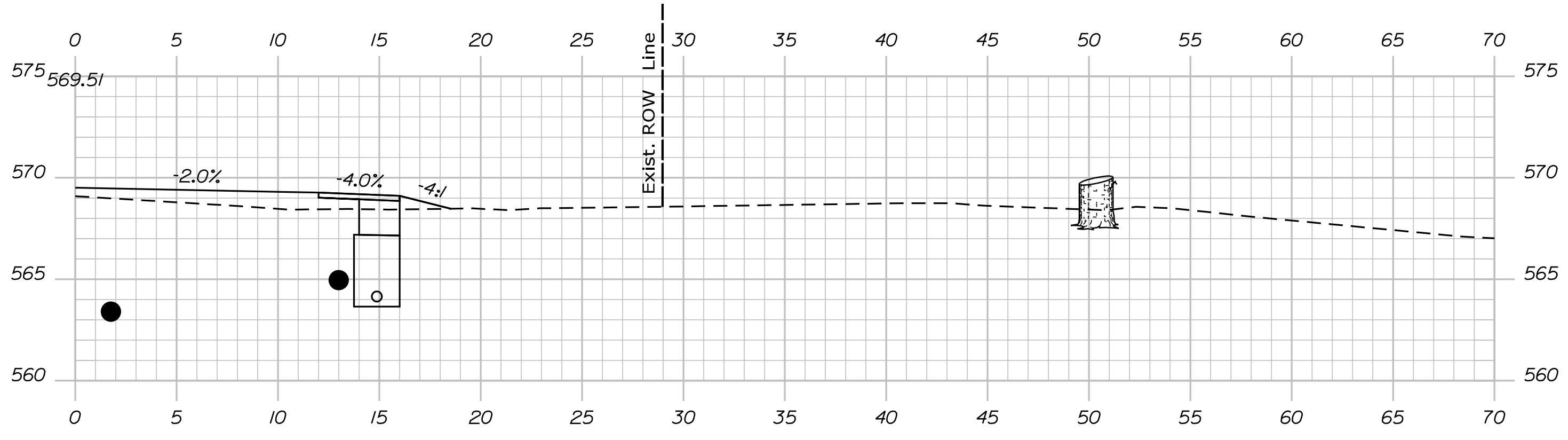

1015+79.00

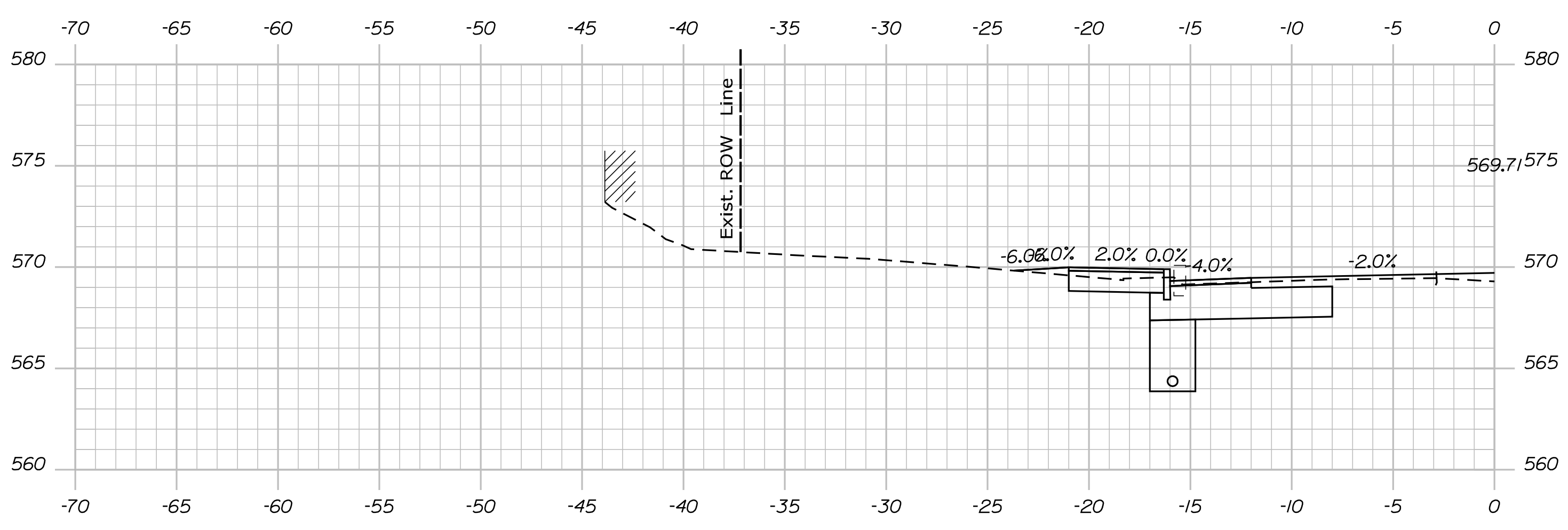

1015+64.50

STATE OF MAINE
DEPARTMENT OF TRANSPORTATION
STP-1824(500)
WIN
18245.00
HIGHWAY PLANS

SIGNATURE
P.E. NUMBER
DATE

PROJ. MANAGER	BY	DATE
DESIGN DETAIL		
CHECKED/REVIEWED		
DESIGN DETAIL		
DESIGN DETAIL		
REVISIONS 1		
REVISIONS 2		
REVISIONS 3		
REVISIONS 4		
FIELD CHANGES		

KINGFIELD
ROUTE 16\27
CROSS SECTIONS

SHEET NUMBER
Xse
OF 175

Date: \$date\$

Username:

Division: HIGHWAY

Filename: ... \Bentley\ustrn\Xsect.dgn

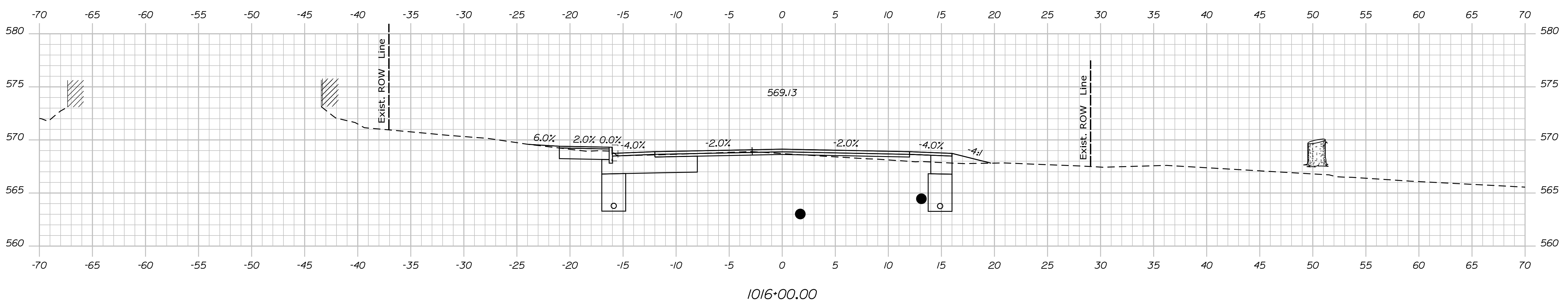
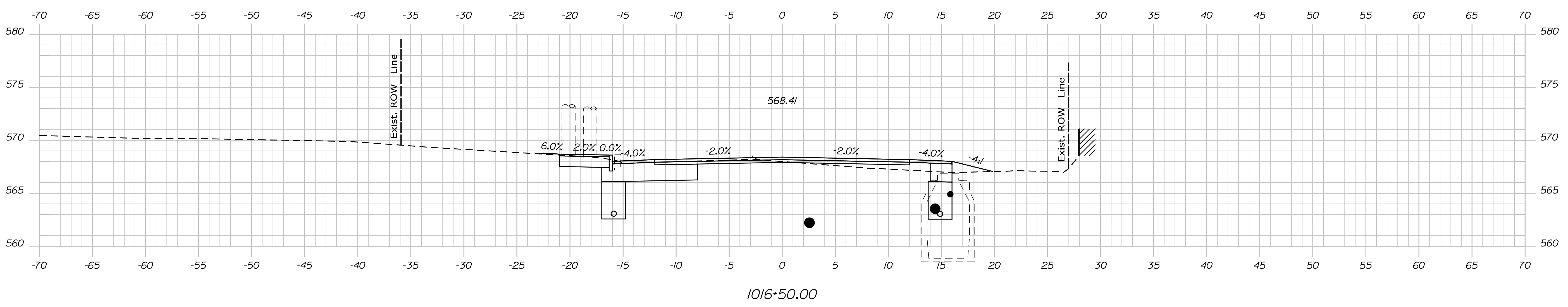
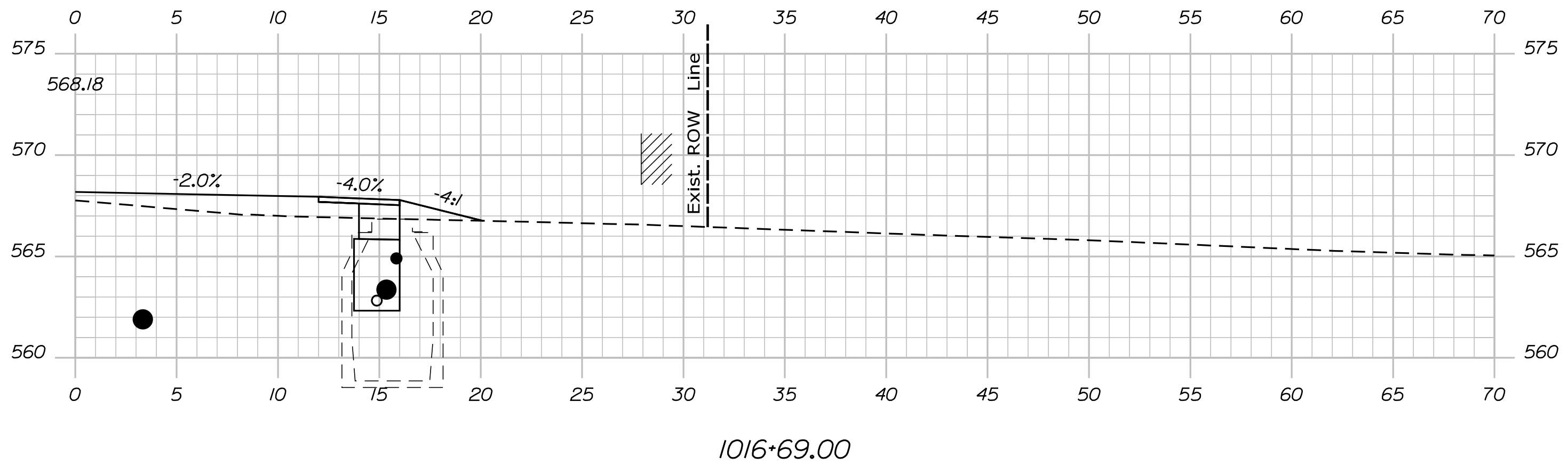

STATE OF MAINE
DEPARTMENT OF TRANSPORTATION
STP-1824(500)

WIN
18245.00
HIERARCHIC PLANS

PROJ. MANAGER	DATE
DESIGN/DETAILED	
CHECKED/REVIEWED	
DESIGN/DETAILED	
DESIGN/DETAILED	
REVISIONS 1	
REVISIONS 2	
REVISIONS 3	
REVISIONS 4	
FIELD CHANGES	

KINGFIELD
ROUTE 16\27
CROSS SECTIONS

SHEET NUMBER
Xse
OF 175

Date: \$date\$

Username:

Division: HIGHWAY

Filename: ... \Bentley\ustn\Xsect.dgn

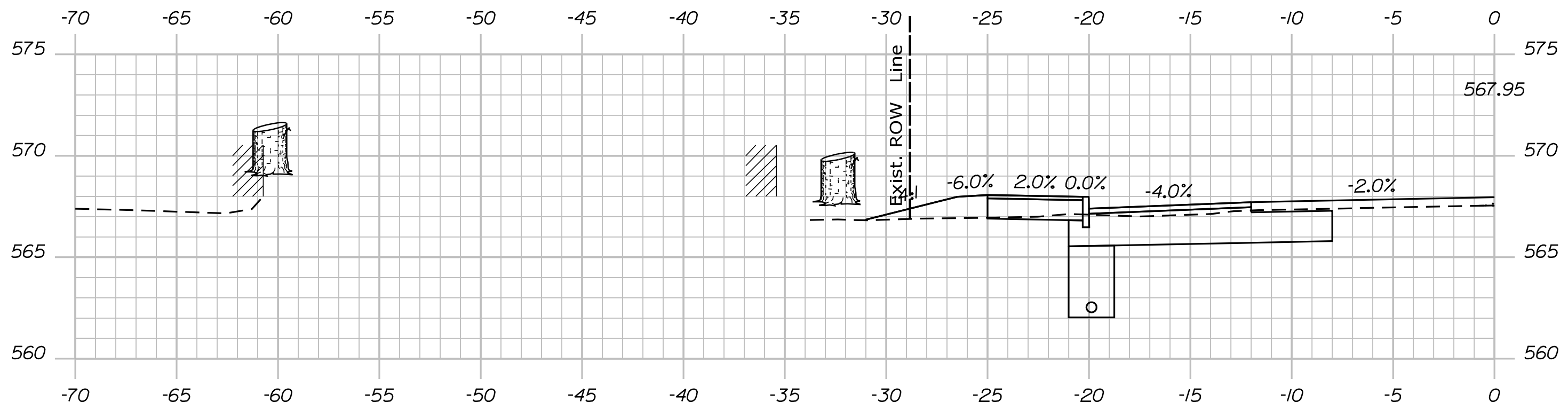

1017+49.00

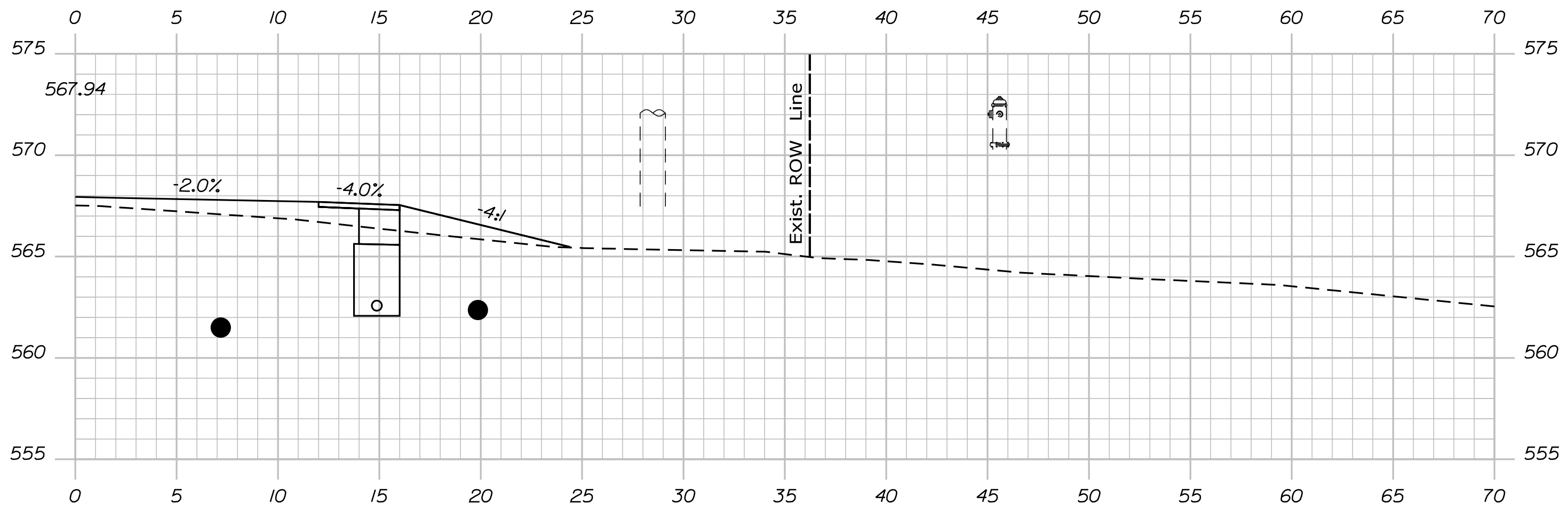

1017+27.00

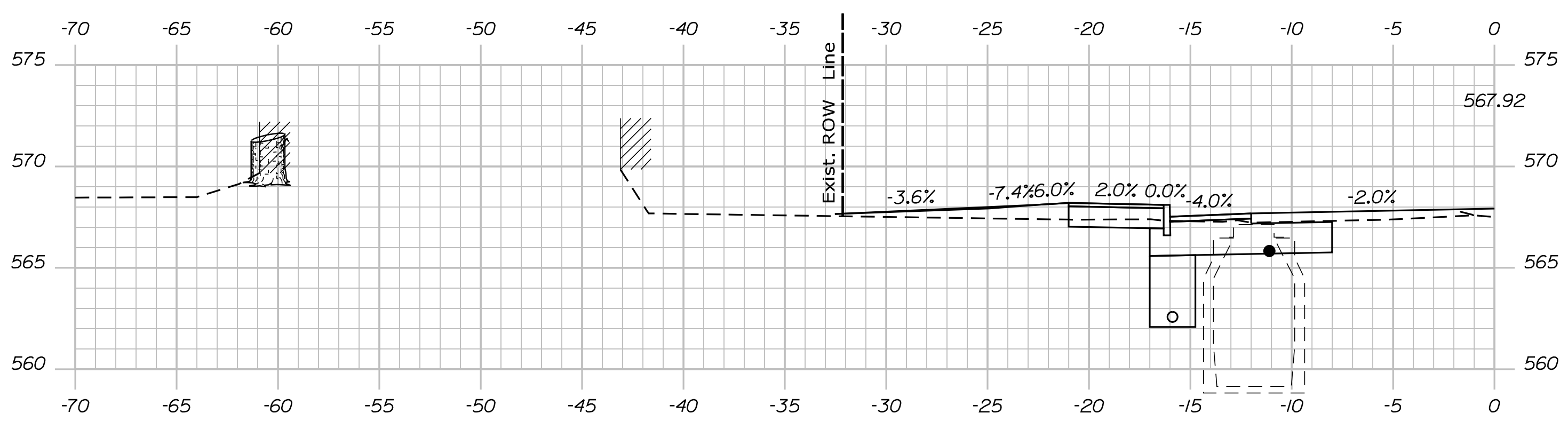

1017+12.50

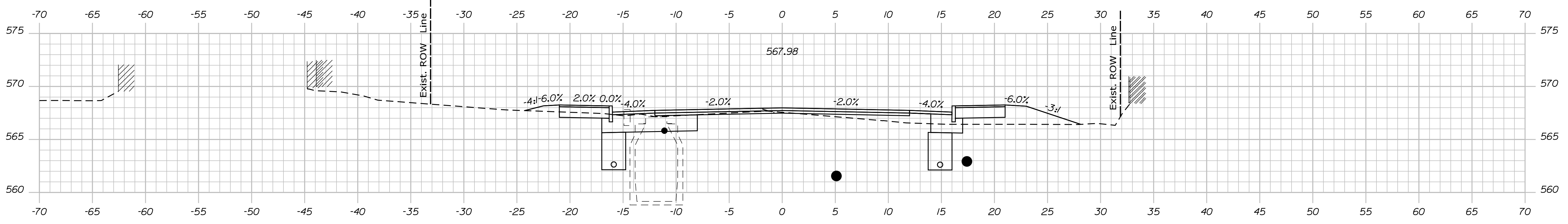

1017+00.00

STATE OF MAINE
DEPARTMENT OF TRANSPORTATION
STP-1824(500)
WIN
18245.00
HIERARCHIC PLANS

PROJ. MANAGER	DATE
DESIGN DETAILED	
CHECKED/REVIEWED	
DESIGN DETAILED	
DESIGN DETAILED	
REVISIONS 1	
REVISIONS 2	
REVISIONS 3	
REVISIONS 4	
FIELD CHANGES	

KINGFIELD
ROUTE 16\27
CROSS SECTIONS

SHEET NUMBER
Xse
OF 175

Date: \$date\$

Username:

Division: HIGHWAY

Filename: ... \Bentley\ustrn\Xsect.dgn

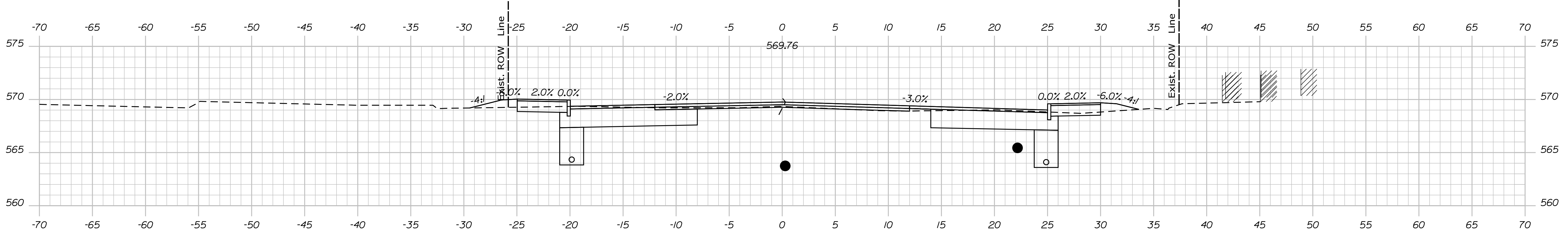

1018+50.00

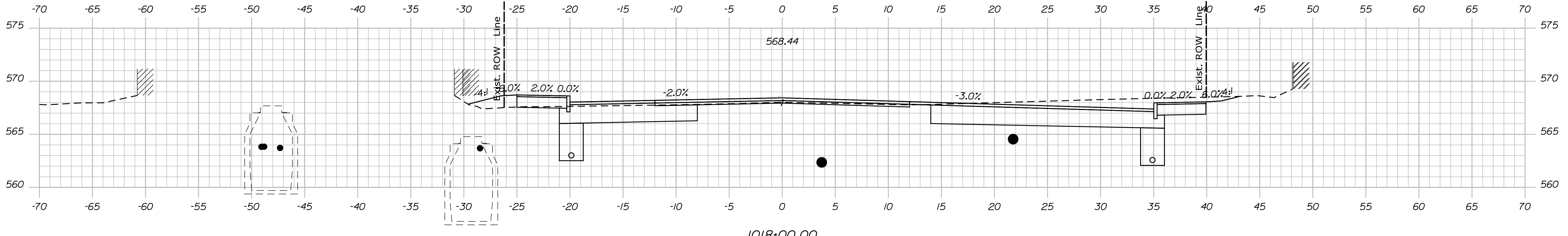

1018+00.00

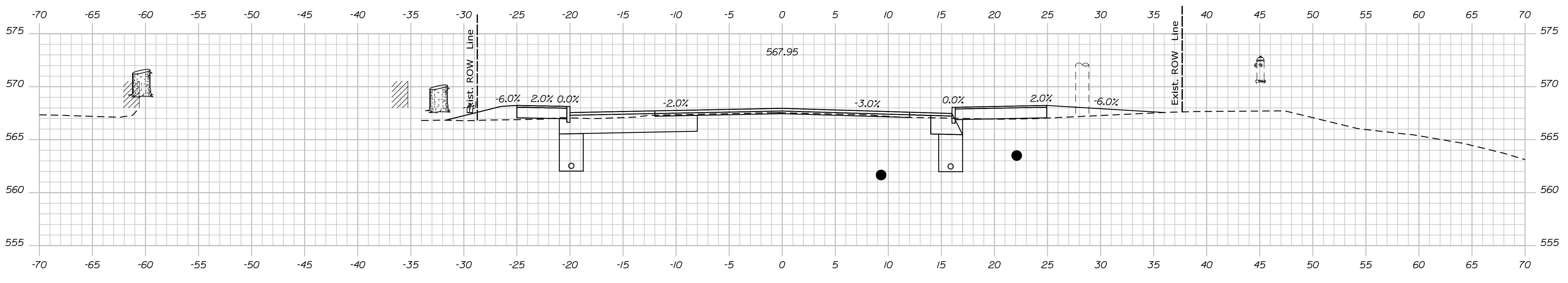

1017+50.00

STATE OF MAINE
DEPARTMENT OF TRANSPORTATION
STP-1824(500)

WIN
18245.00
HIERARCHIC PLANS

PROJ. MANAGER	DATE	BY	DATE
DESIGN DETAILED			
CHECKED/REVISED			
DESIGN DETAILED			
DESIGN DETAILED			
REVISIONS 1			
REVISIONS 2			
REVISIONS 3			
REVISIONS 4			
FIELD CHANGES			

KINGFIELD
ROUTE 16\27
CROSS SECTIONS

SHEET NUMBER
Xse
OF 175

Date: \$date\$

Username:

Division: HIGHWAY

Filename: ... \Bentley\ustrn\Xsect.dgn

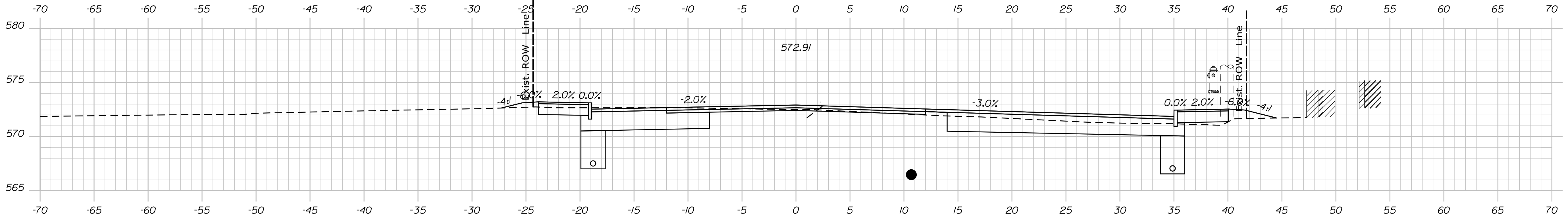

1019+50.00

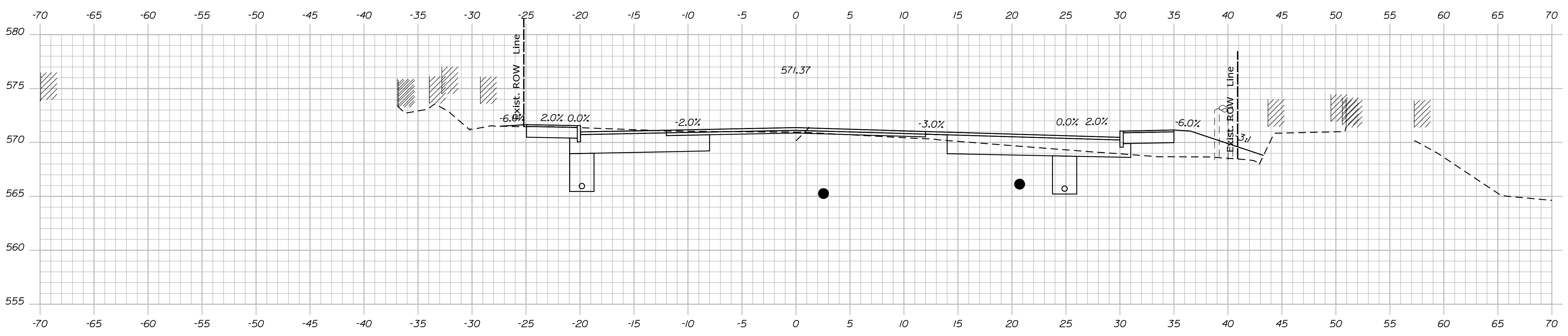

1019+00.00

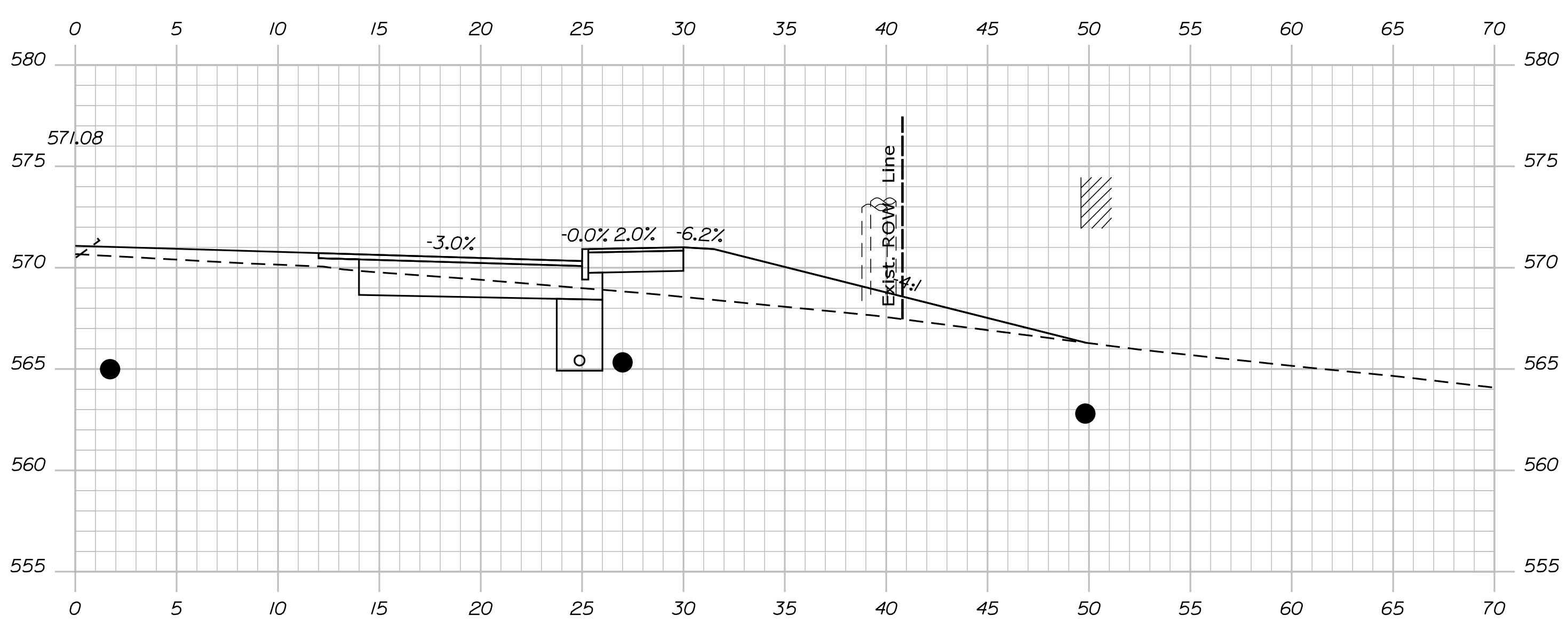

1018+91.00

STATE OF MAINE
DEPARTMENT OF TRANSPORTATION
STP-1824(500)
WIN
18245.00
HIERARCHIC PLANS

PROJ. MANAGER	DATE	BY	SIGNATURE
DESIGN DETAILER			
CHECKED/REVIEWED			
DESIGN DETAILER			
DESIGN DETAILER			
REVISIONS 1			
REVISIONS 2			
REVISIONS 3			
REVISIONS 4			
FIELD CHANGES			

KINGFIELD
ROUTE 16\27
CROSS SECTIONS

SHEET NUMBER
Xse
OF 175

Date: \$date\$

Username:

Division: HIGHWAY

Filename: ... \Bentley\ustrn\Xsect.dgn

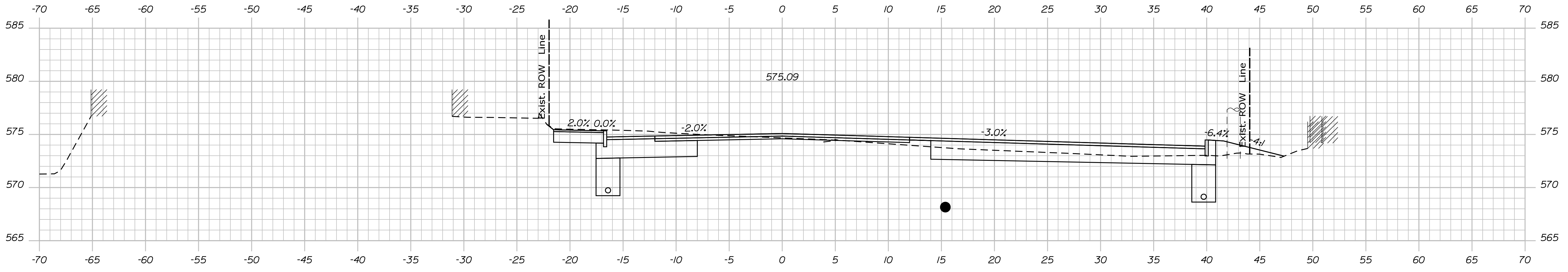

1020+50.00

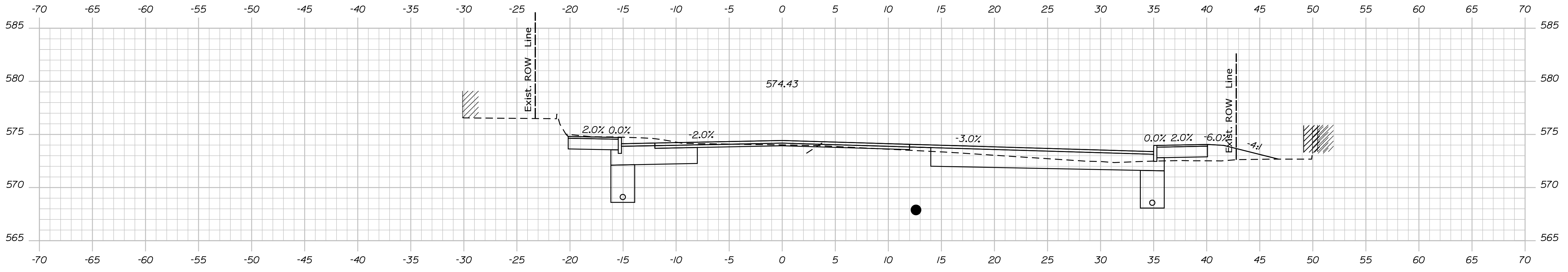

1020+00.00

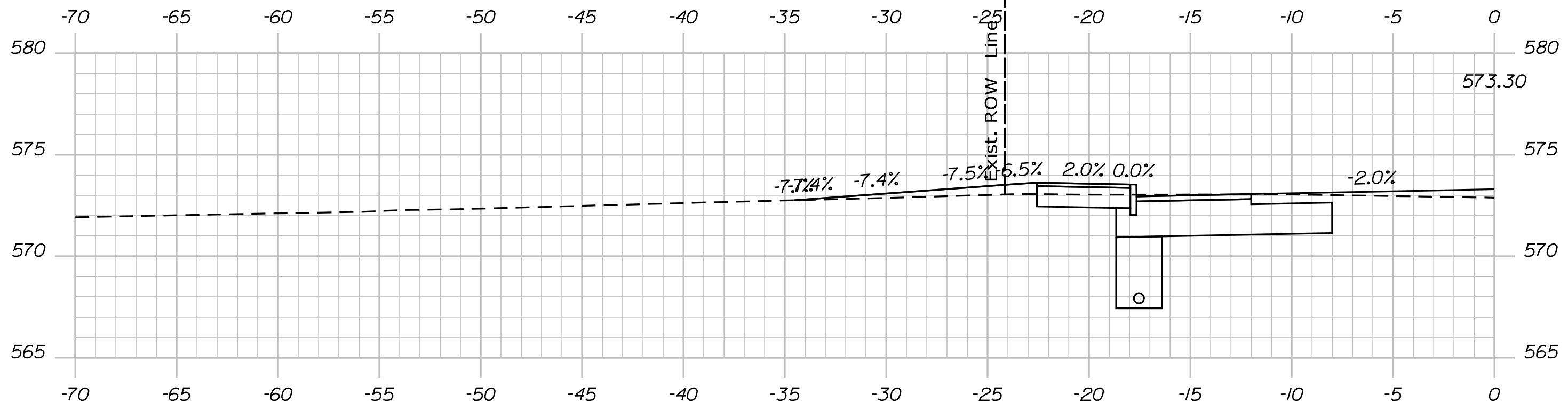

1019+62.00

STATE OF MAINE
 DEPARTMENT OF TRANSPORTATION
 STP-1824(500)
 WIN
 18245.00
 HIGHWAY PLANS

SIGNATURE
 P.E. NUMBER
 DATE

PROJ. MANAGER	DATE
DESIGN DETAILER	
CHECKED/REVIEWED	
DESIGN DETAILER	
DESIGN DETAILER	
REVISIONS 1	
REVISIONS 2	
REVISIONS 3	
REVISIONS 4	
FIELD CHANGES	

KINGFIELD
 ROUTE 16\27
 CROSS SECTIONS

SHEET NUMBER
Xse
 OF 175

Date: \$date\$

Username:

Division: HIGHWAY

Filename: ... \Bentley\ustrn\Xsect.dgn

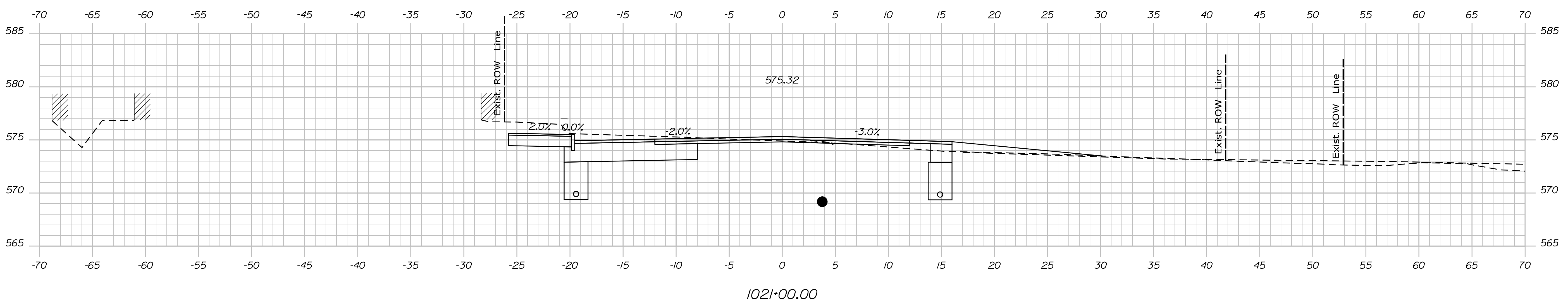
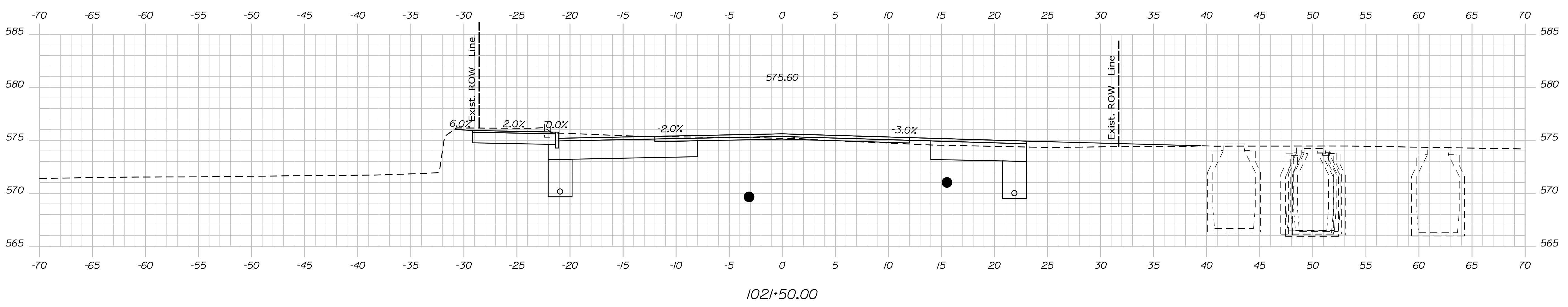
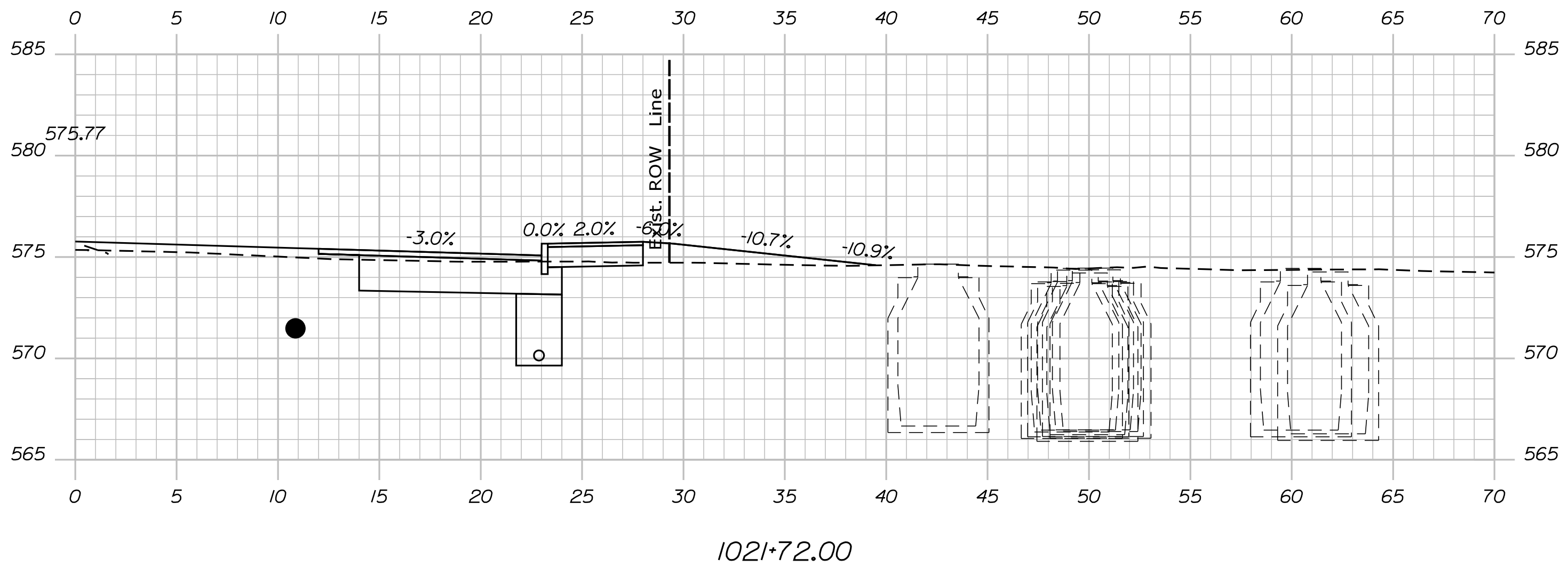

STATE OF MAINE
DEPARTMENT OF TRANSPORTATION
STP-1824(500)
WIN
18245.00
HIERARCHIC PLANS

SIGNATURE
P.E. NUMBER
DATE

PROJ. MANAGER	DATE
DESIGN DETAIL	
CHECKED/REVIEWED	
DESIGN DETAIL	
DESIGN DETAIL	
REVISIONS 1	
REVISIONS 2	
REVISIONS 3	
REVISIONS 4	
FIELD CHANGES	

KINGFIELD
ROUTE 16\27
CROSS SECTIONS

SHEET NUMBER
Xse
OF 175

Date: \$date\$

Username:

Division: HIGHWAY

Filename: ... \Bentley\ustrn\Xsect.dgn

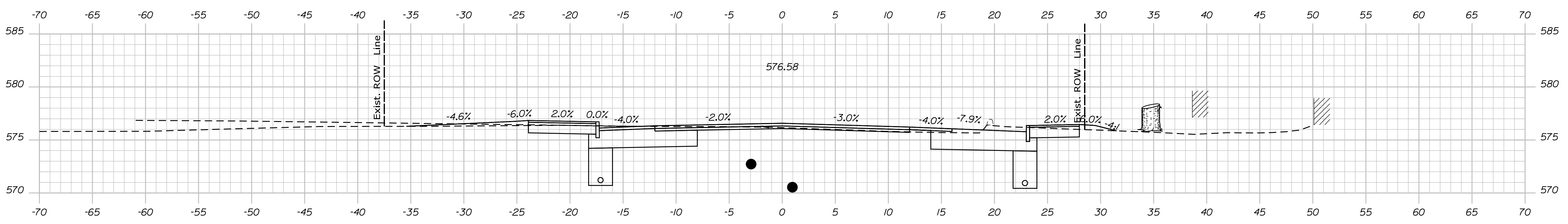

1023+00.00

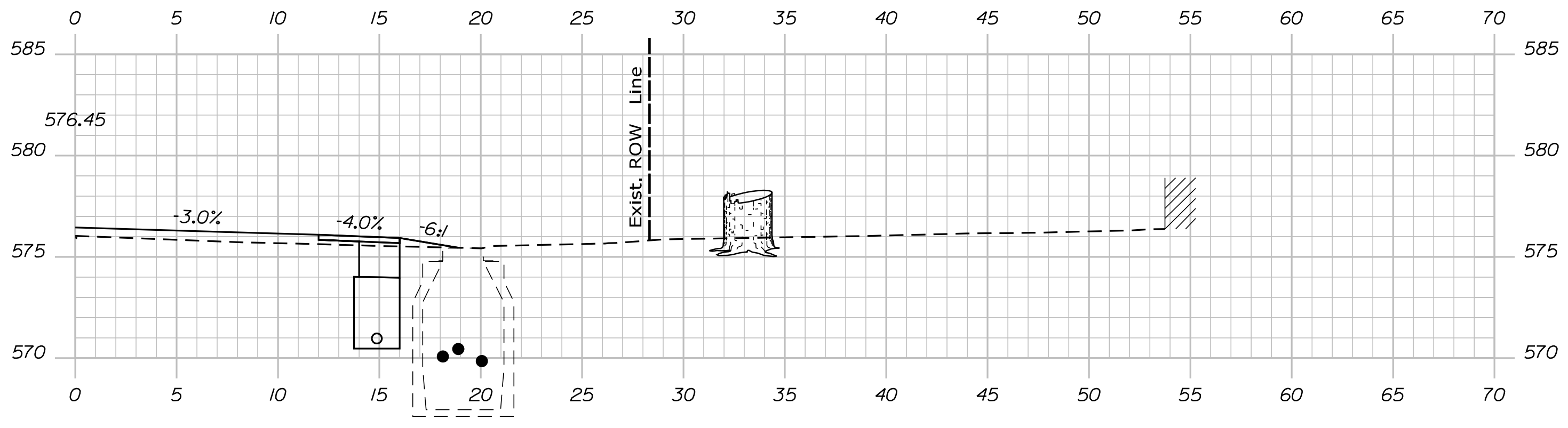

1022+72.00

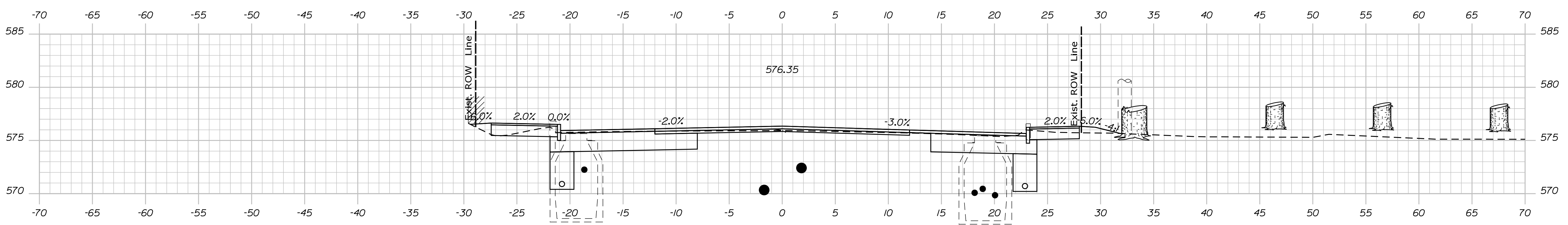

1022+50.00

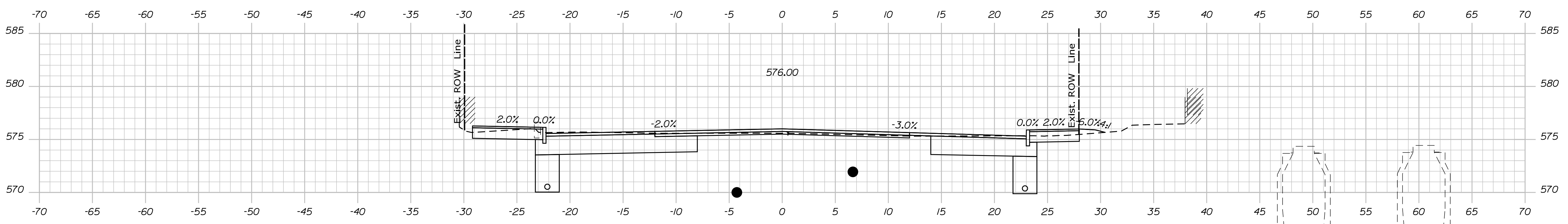

1022+00.00

STATE OF MAINE
DEPARTMENT OF TRANSPORTATION
STP-1824(500)
WIN
18245.00
HIERARCHIC PLANS

PROJ. MANAGER	DATE	BY	DATE
DESIGN DETAILED			
CHECKED/REVIEWED			
DESIGN DETAILED			
DESIGN DETAILED			
REVISIONS 1			
REVISIONS 2			
REVISIONS 3			
REVISIONS 4			
FIELD CHANGES			

KINGFIELD
ROUTE 16\27
CROSS SECTIONS

SHEET NUMBER
Xse
OF 175

Date: \$date\$

Username:

Division: HIGHWAY

Filename: ... \Bentley\ustrn\Xsect.dgn

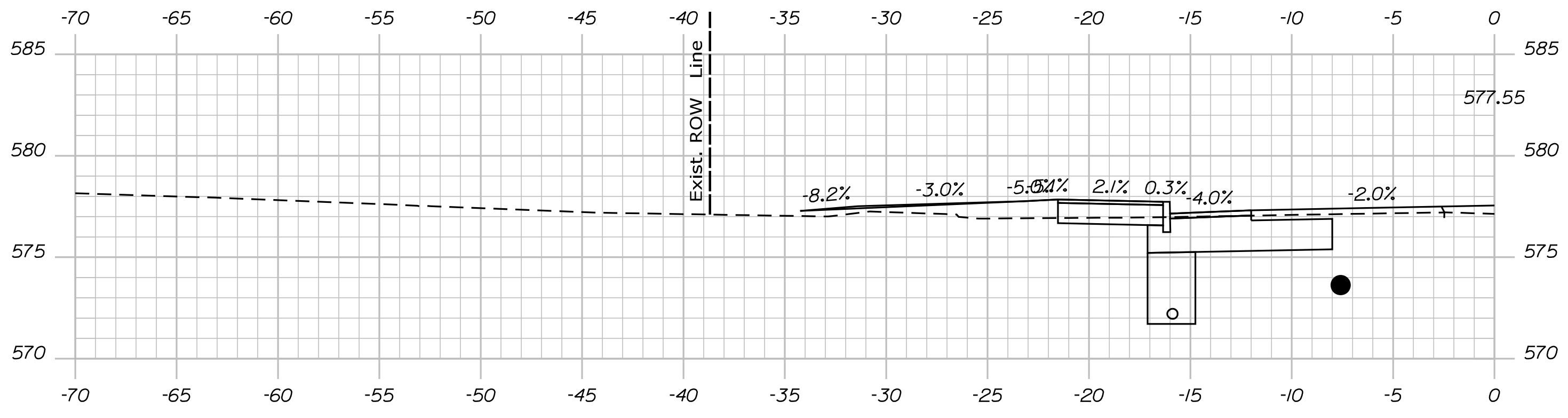

1024+46.00

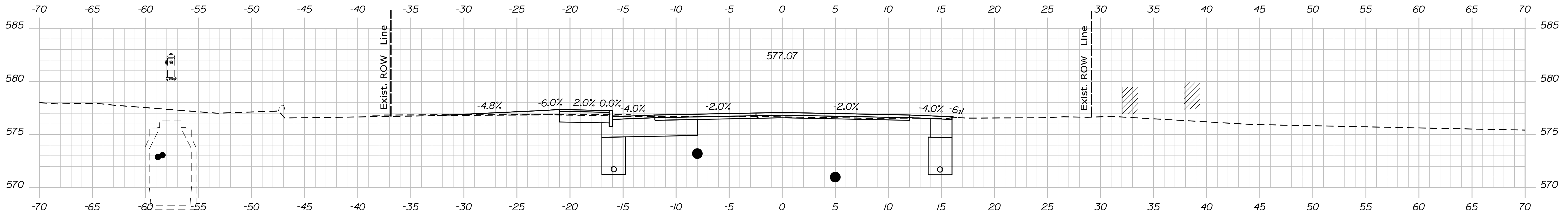

1024+00.00

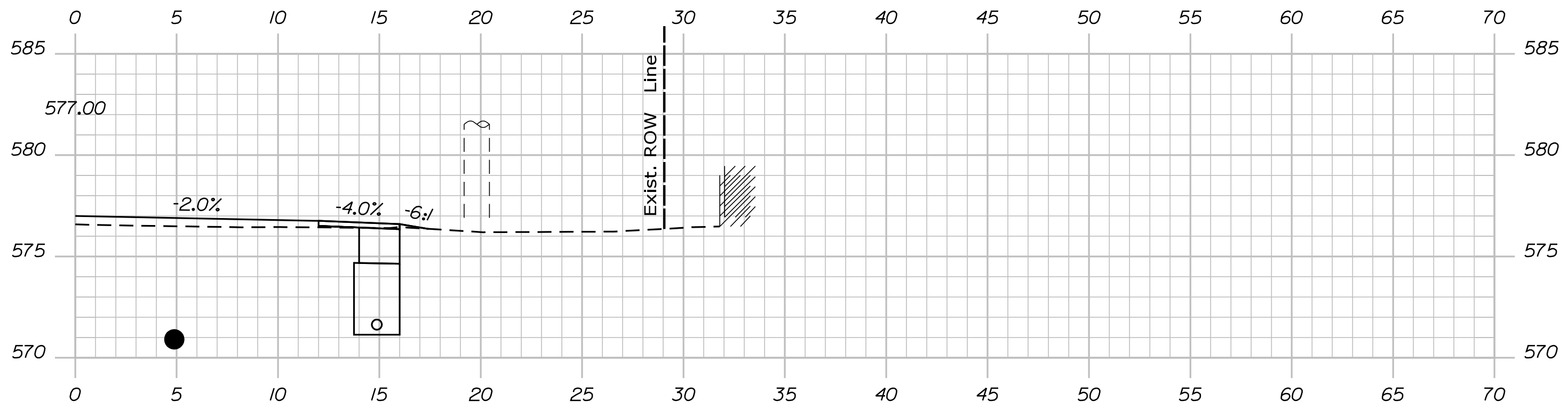

1023+88.00

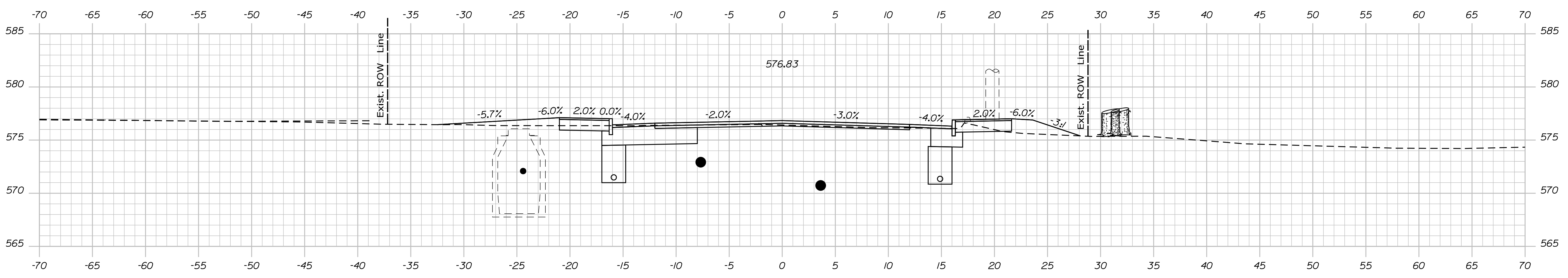

1023+50.00

STATE OF MAINE
DEPARTMENT OF TRANSPORTATION
STP-1824(500)
WIN
18245.00
HIERARCHIC PLANS

PROJ. MANAGER	DATE	BY	DATE
DESIGN/DETAILED			
CHECKED/REVIEWED			
DESIGN/DETAILED			
DESIGN/DETAILED			
REVISIONS 1			
REVISIONS 2			
REVISIONS 3			
REVISIONS 4			
FIELD CHANGES			

KINGFIELD
ROUTE 16\27
CROSS SECTIONS

SHEET NUMBER
Xse
OF 175

Date: \$date\$

Username:

Division: HIGHWAY

Filename: ... \Bentley\ustrn\Xsect.dgn

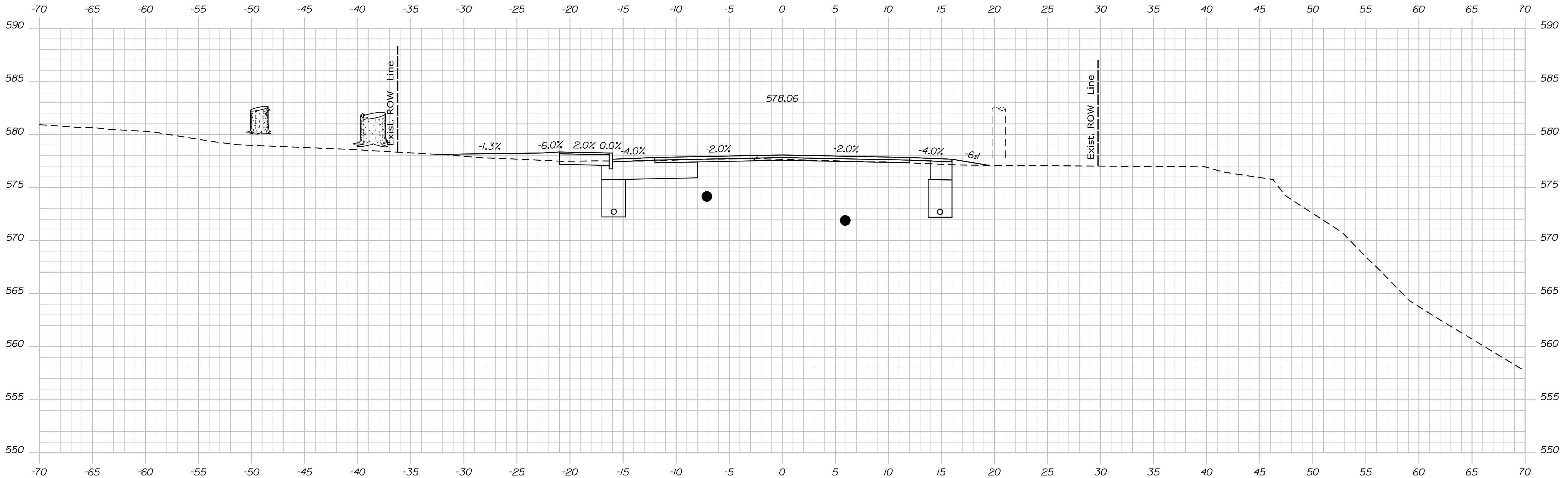

1025+00.00

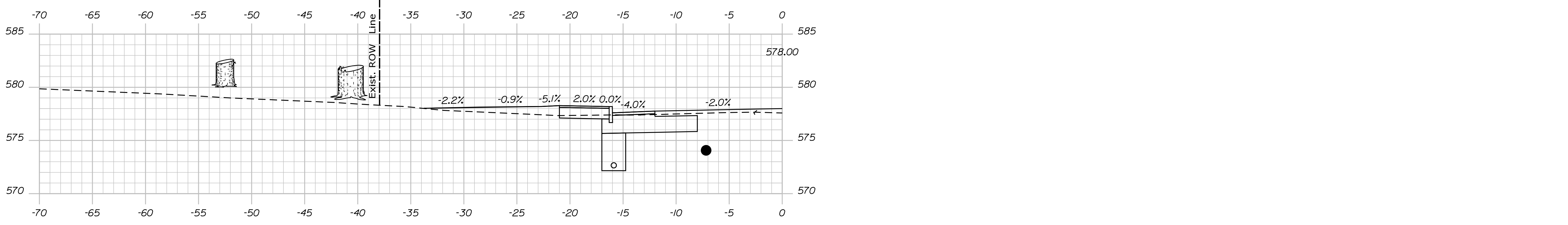

1024+92.00

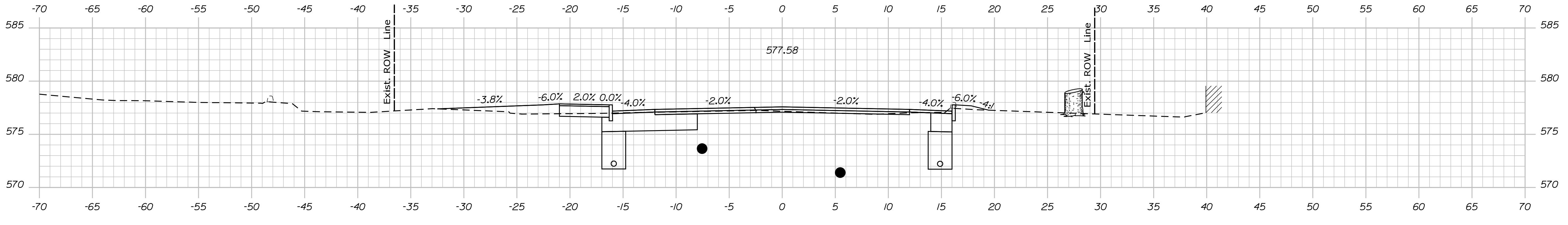

1024+50.00

STATE OF MAINE
 DEPARTMENT OF TRANSPORTATION
 STP-1824(500)
 WIN
 18245.00
 HIGHWAY PLANS

SIGNATURE
 P.E. NUMBER
 DATE

PROJ. MANAGER	DATE
DESIGN DETAILED	
CHECKED/REVIEWED	
DESIGN DETAILED	
DESIGN DETAILED	
REVISIONS 1	
REVISIONS 2	
REVISIONS 3	
REVISIONS 4	
FIELD CHANGES	

KINGFIELD
 ROUTE 16\27
 CROSS SECTIONS

SHEET NUMBER
Xse
 OF 175

Date: \$date\$

Username:

Division: HIGHWAY

Filename: ... \Bentley\ustrn\Xsect.dgn

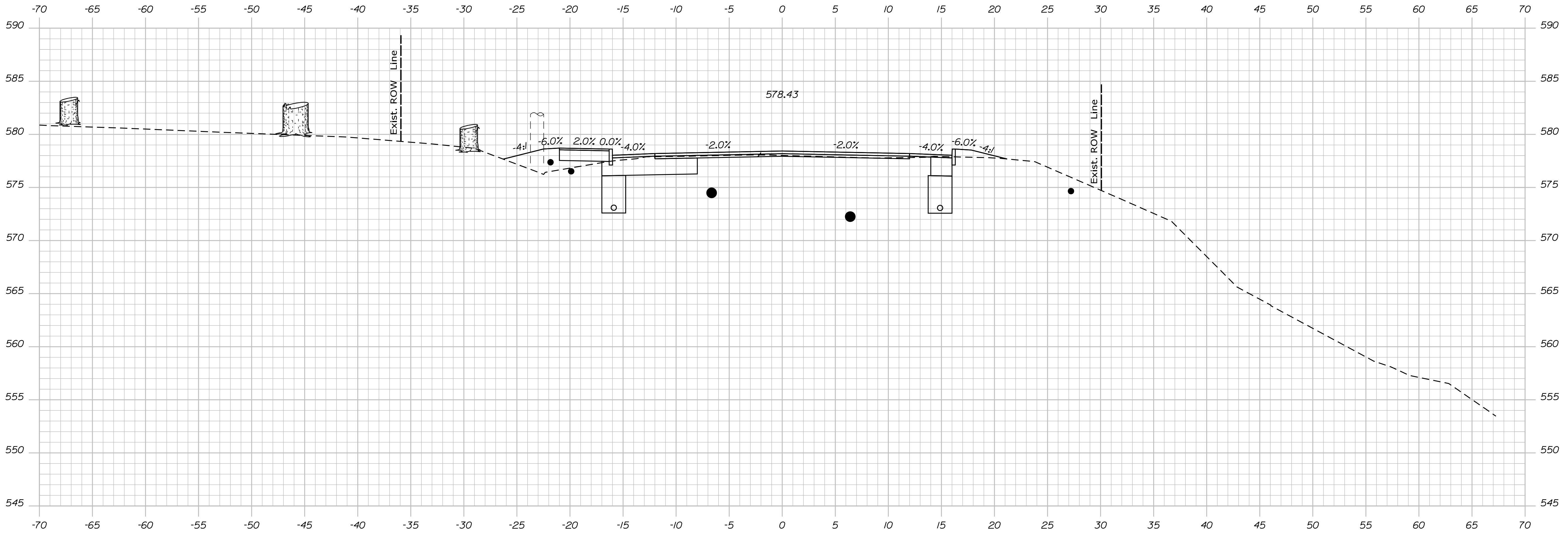

1025+50.00

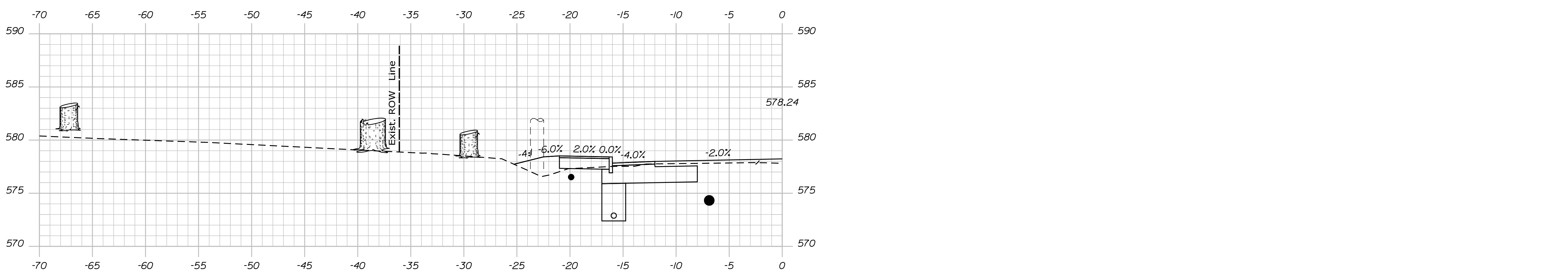

1025+25.00

STATE OF MAINE
DEPARTMENT OF TRANSPORTATION
STP-1824(500)
WIN
18245.00
HIERARCHIC PLANS

SIGNATURE
P.E. NUMBER
DATE

PROJ. MANAGER	DATE
DESIGN DETAIL	
CHECKED/REVIEWED	
DESIGN DETAIL	
DESIGN DETAIL	
REVISIONS 1	
REVISIONS 2	
REVISIONS 3	
REVISIONS 4	
FIELD CHANGES	

KINGFIELD
ROUTE 16\27
CROSS SECTIONS

SHEET NUMBER
Xse
OF 175

Date: \$date\$

Username:

Division: HIGHWAY

Filename: ... \Bentley\ustr\Xsect.dgn

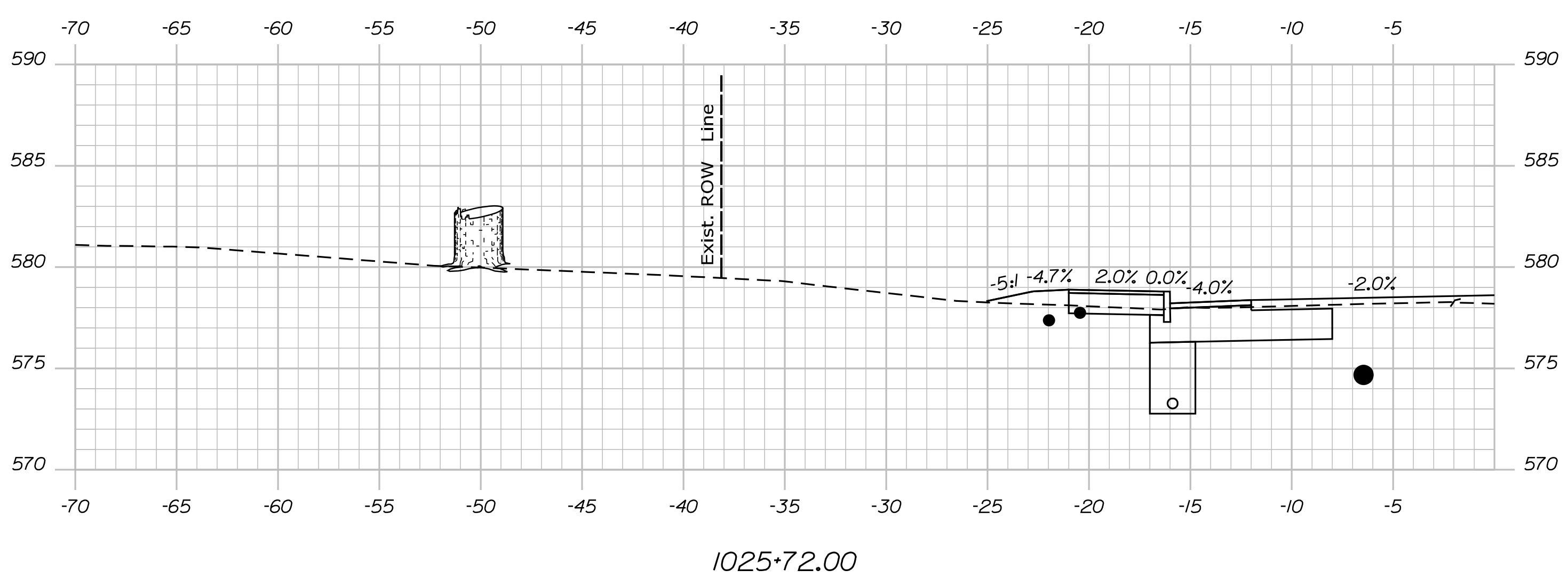
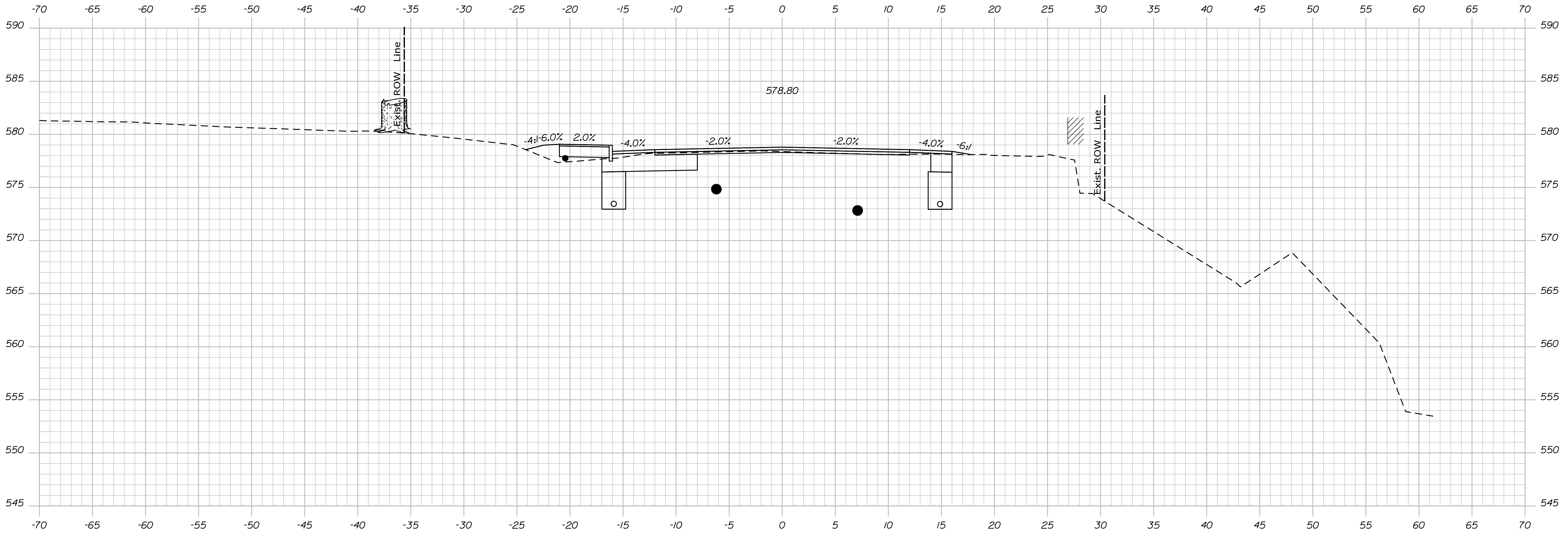

STATE OF MAINE
 DEPARTMENT OF TRANSPORTATION
STP-1824(500)
 WIN
 18245.00
 HIGHWAY PLANS

SIGNATURE
 P.E. NUMBER
 DATE

PROJ. MANAGER	DATE
DESIGN DETAIL	
CHECKED/REVIEWED	
DESIGN DETAIL	
DESIGN DETAIL	
REVISIONS 1	
REVISIONS 2	
REVISIONS 3	
REVISIONS 4	
FIELD CHANGES	

KINGFIELD
 ROUTE 16\27
 CROSS SECTIONS

SHEET NUMBER
Xse
 OF 175

Date: \$date\$

Username:

Division: HIGHWAY

Filename: ... \Bentley\ustrn\Xsect.dgn

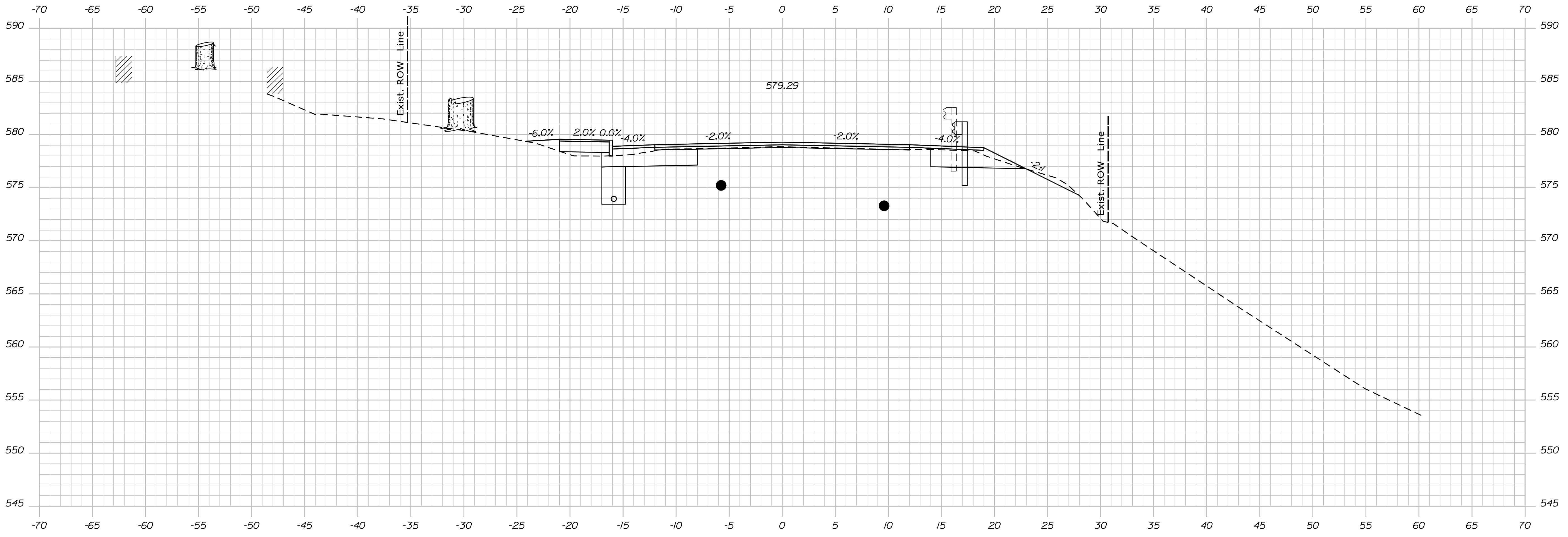

1026+50.00

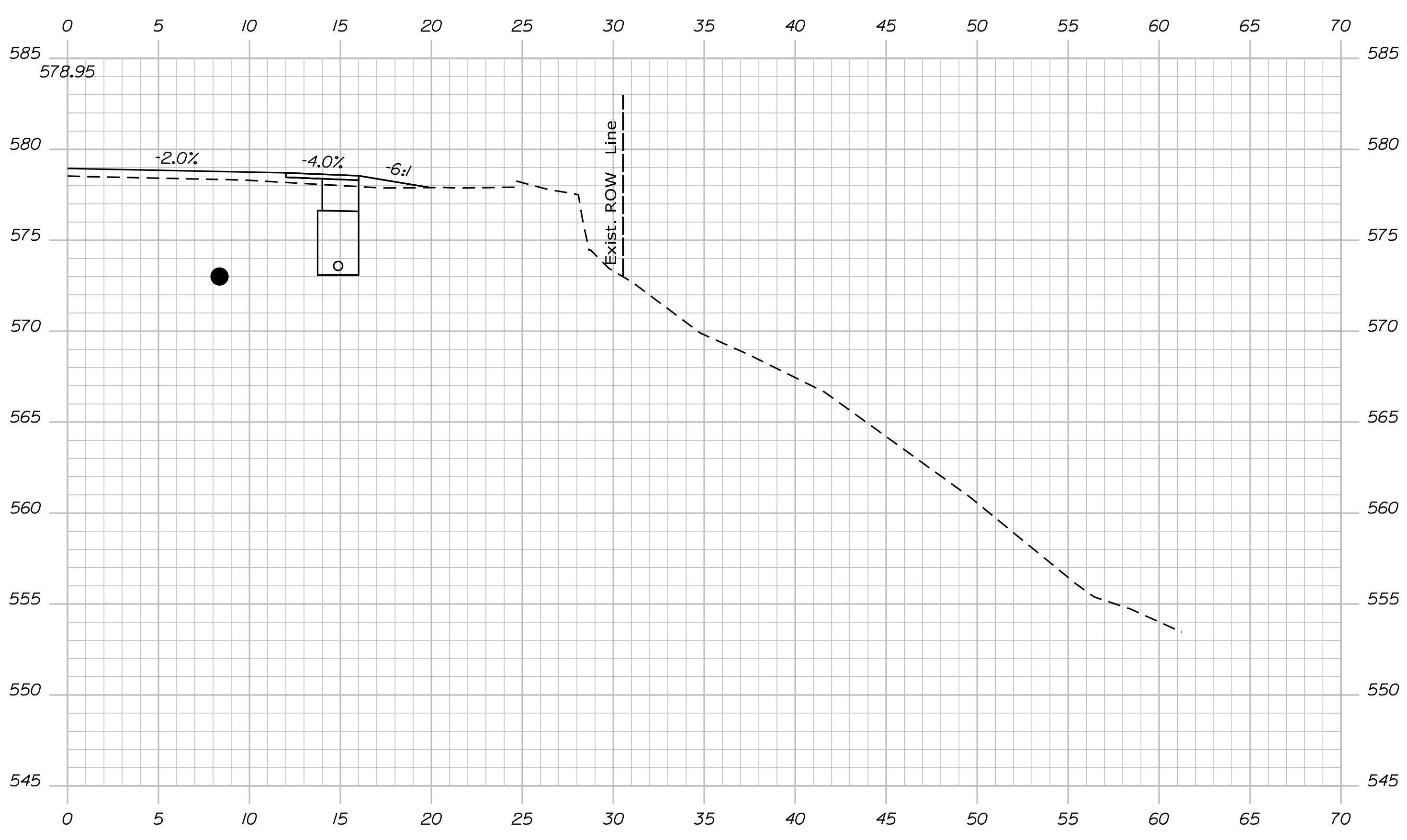

1026+25.00

STATE OF MAINE
DEPARTMENT OF TRANSPORTATION
STP-1824(500)
WIN
18245.00
HIGHWAY PLANS

SIGNATURE
P.E. NUMBER
DATE

PROJ. MANAGER	DATE
DESIGN DETAIL	
CHECKED/REVIEWED	
DESIGN DETAIL	
DESIGN DETAIL	
REVISIONS 1	
REVISIONS 2	
REVISIONS 3	
REVISIONS 4	
FIELD CHANGES	

KINGFIELD
ROUTE 16\27
CROSS SECTIONS

SHEET NUMBER
Xse
OF 175

Date: \$date\$

Username:

Division: HIGHWAY

Filename: ... \Bentley\ustr\Xsect.dgn

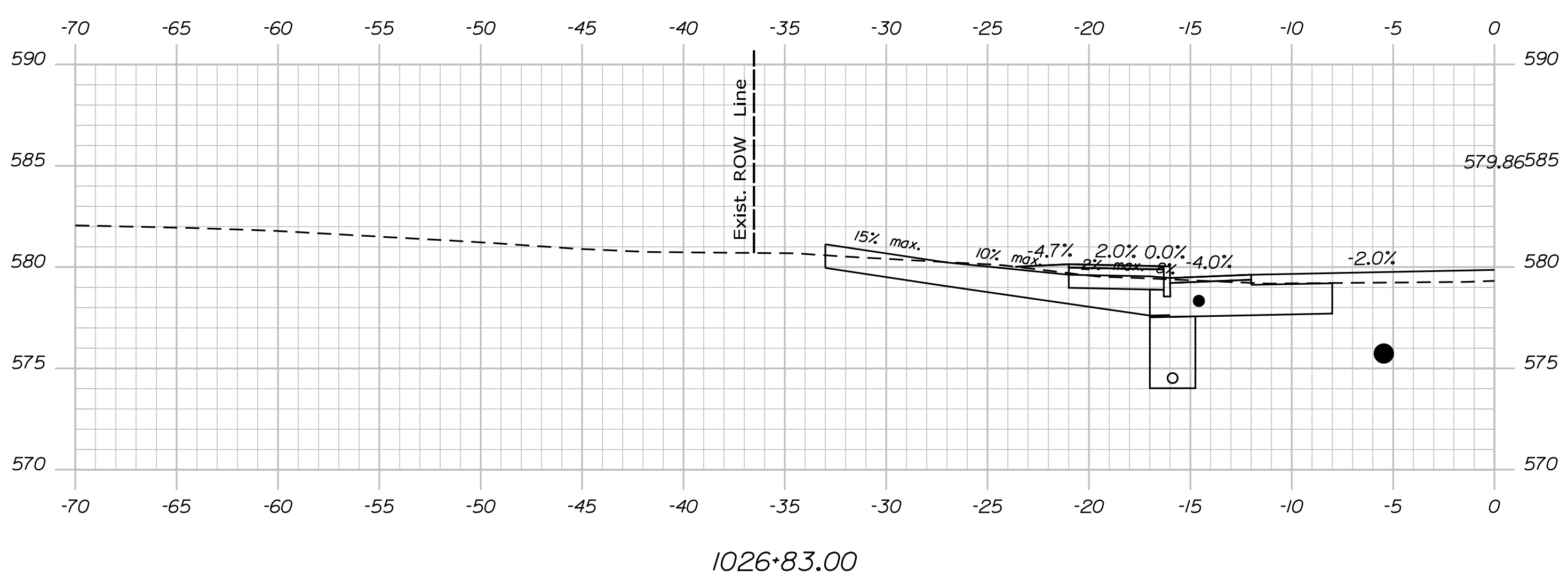
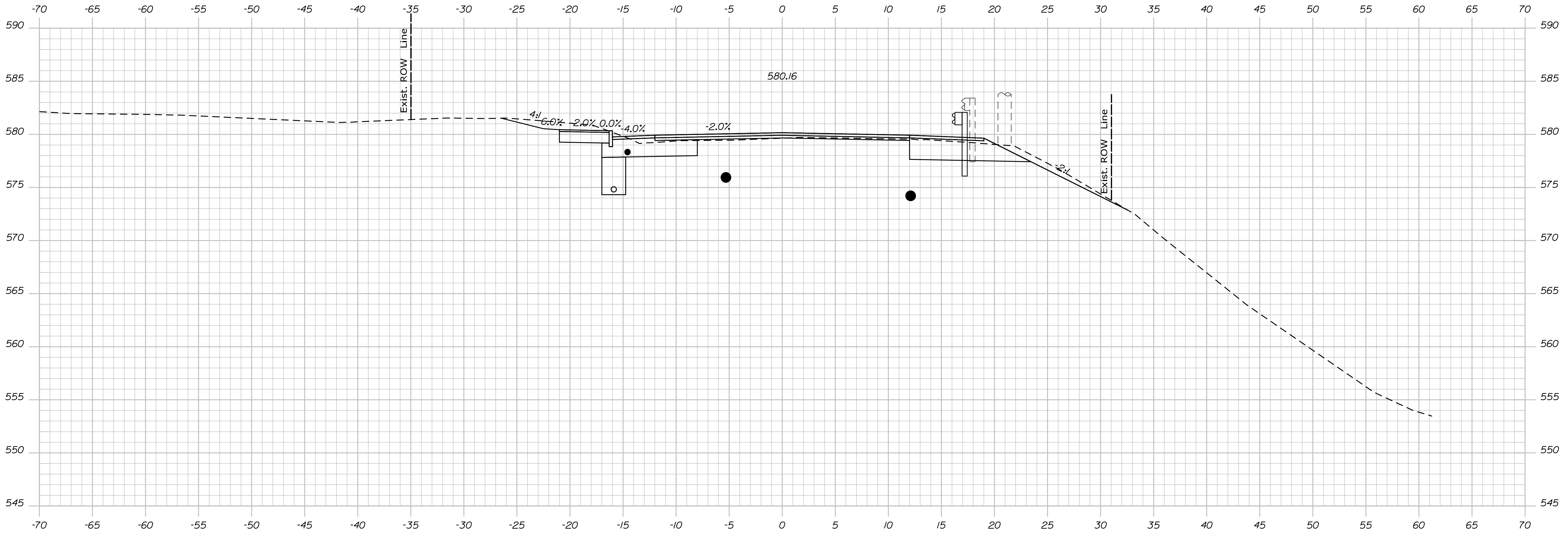

STATE OF MAINE
DEPARTMENT OF TRANSPORTATION
STP-1824(500)
WIN
18245.00
HIERARCHIC PLANS

SIGNATURE
P.E. NUMBER
DATE

PROJ. MANAGER	DATE
DESIGN DETAILED	
CHECKED/REVIEWED	
DESIGN DETAILED	
DESIGN DETAILED	
REVISIONS 1	
REVISIONS 2	
REVISIONS 3	
REVISIONS 4	
FIELD CHANGES	

KINGFIELD
ROUTE 16\27
CROSS SECTIONS

SHEET NUMBER
Xse
OF 175

Date: \$date\$

Username:

Division: HIGHWAY

Filename: ... \Bentley\ustrn\Xsect.dgn

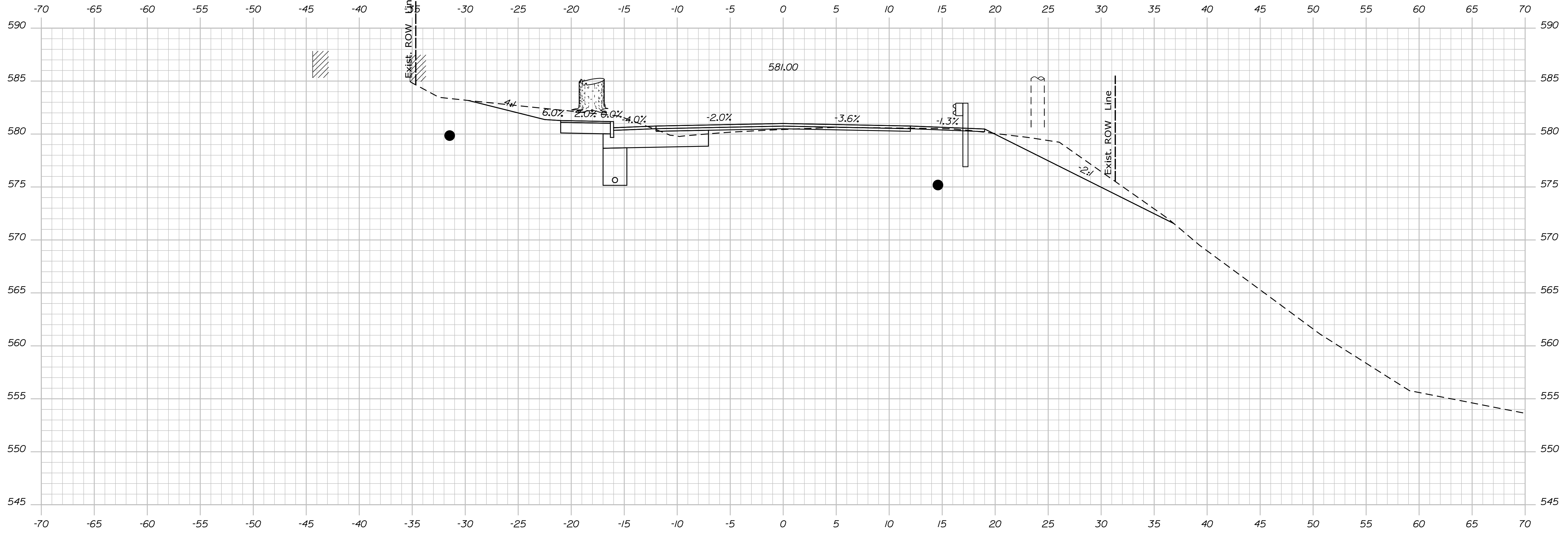

1027+50.00

STATE OF MAINE
 DEPARTMENT OF TRANSPORTATION
STP-1824(500)

WIN
 18245.00
 HIERARCHIC PLANS

PROJ. MANAGER	BY	DATE
DESIGN DETAIL		
CHECKED/REVISED		
DESIGN DETAIL		
DESIGN DETAIL		
REVISIONS 1		
REVISIONS 2		
REVISIONS 3		
REVISIONS 4		
FIELD CHANGES		

**KINGFIELD
 ROUTE 16\27
 CROSS SECTIONS**

SHEET NUMBER
Xse
 OF 175

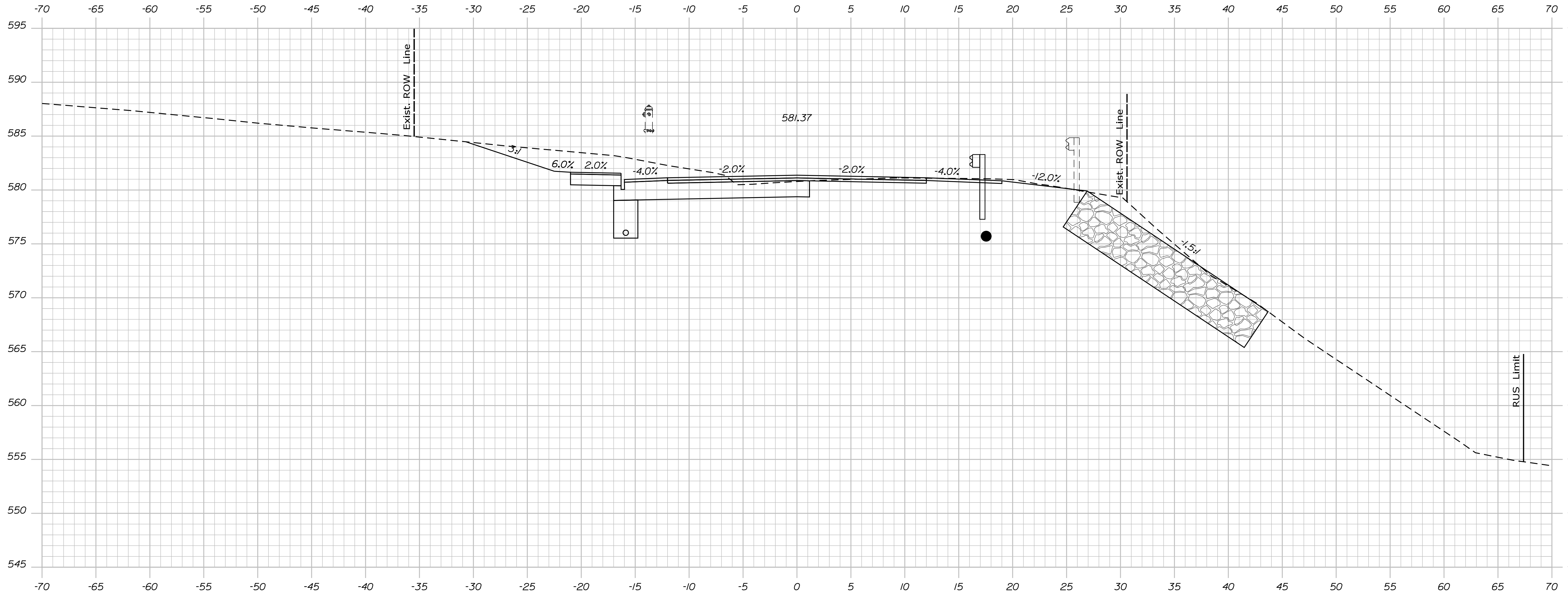

1028+00.00

Sta. 1028+00.00 to Sta. 1028+00.00

STATE OF MAINE
 DEPARTMENT OF TRANSPORTATION
STP-1824(500)

SIGNATURE
 P.E. NUMBER
 DATE

PROJ. MANAGER	DATE
DESIGN DETAIL	
CHECKED/REVIEWED	
DESIGN DETAIL	
DESIGN DETAIL	
REVISIONS 1	
REVISIONS 2	
REVISIONS 3	
REVISIONS 4	
FIELD CHANGES	

KINGFIELD
 ROUTE 16\27
 CROSS SECTIONS

SHEET NUMBER
Xse
 OF 175

WIN
 18245.00
 HIERARCHIC PLANS

Date: \$date\$

Username:

Division: HIGHWAY

Filename: ... \Bentley\ustrn\Xsect.dgn

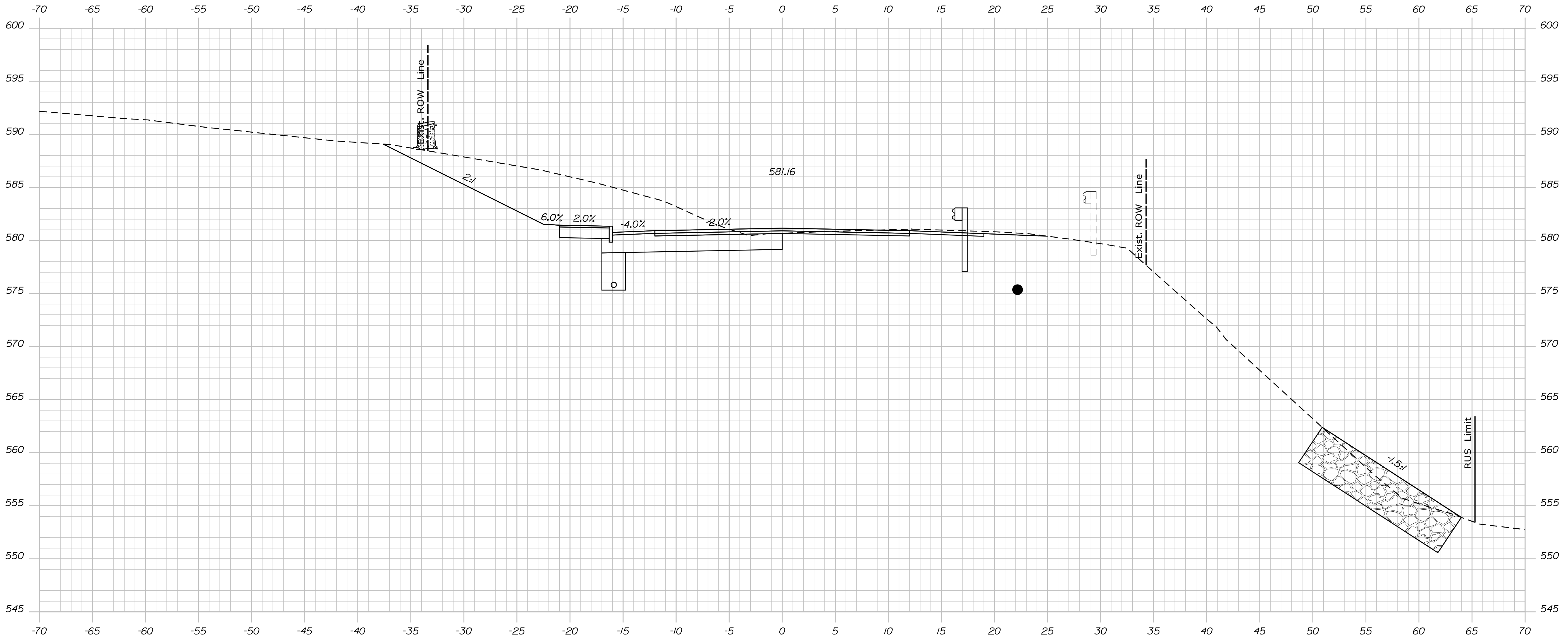

1028+50.00

Sta. 1028+50.00 to Sta. 1028+50.00

STATE OF MAINE
 DEPARTMENT OF TRANSPORTATION
STP-1824(500)

SIGNATURE
 P.E. NUMBER
 DATE

PROJ. MANAGER	BY	DATE
DESIGN/DETAILED		
CHECKED/REVIEWED		
DESIGN/DETAILED		
DESIGN/DETAILED		
REVISIONS 1		
REVISIONS 2		
REVISIONS 3		
REVISIONS 4		
FIELD CHANGES		

KINGFIELD
 ROUTE 16\27
 CROSS SECTIONS

SHEET NUMBER
Xse
 OF 175

WIN
 18245.00
 HIERARCHIC PLANS

Date: \$date\$

Username:

Division: HIGHWAY

Filename: ... \Bentley\ustrn\Xsect.dgn

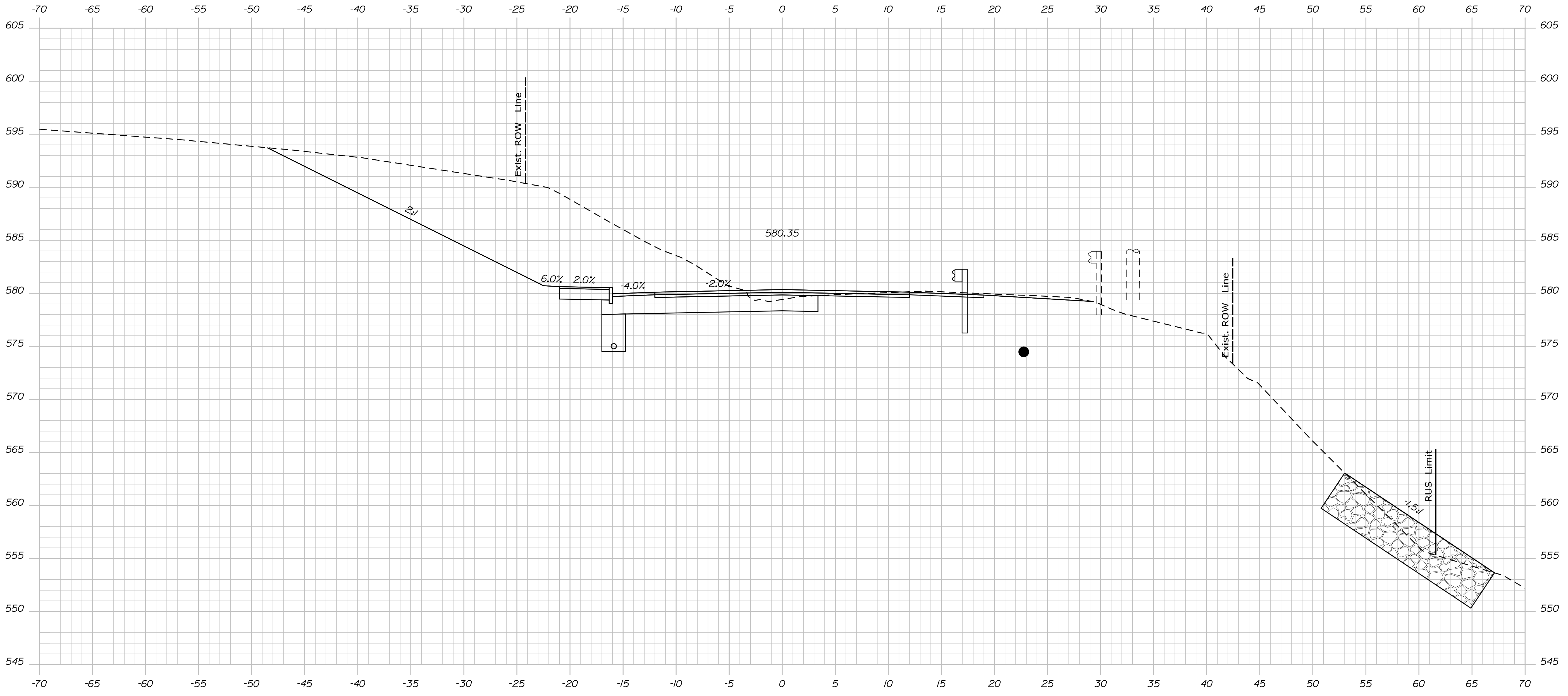

1029+00.00

Sta. 1029+00.00 to Sta. 1029+00.00

STATE OF MAINE
 DEPARTMENT OF TRANSPORTATION
STP-1824(500)

WIN
 18245.00
 HIERARCHIC PLANS

PROJ. MANAGER	BY	DATE
DESIGN DETAILED		
CHECKED/REVIEWED		
DESIGN DETAILED		
DESIGN DETAILED		
REVISIONS 1		
REVISIONS 2		
REVISIONS 3		
REVISIONS 4		
FIELD CHANGES		

**KINGFIELD
 ROUTE 16\27
 CROSS SECTIONS**

SHEET NUMBER
Xse
 OF 175

Date: \$date\$

Username:

Division: HIGHWAY

Filename: ... \Bentley\ustrn\Xsect.dgn

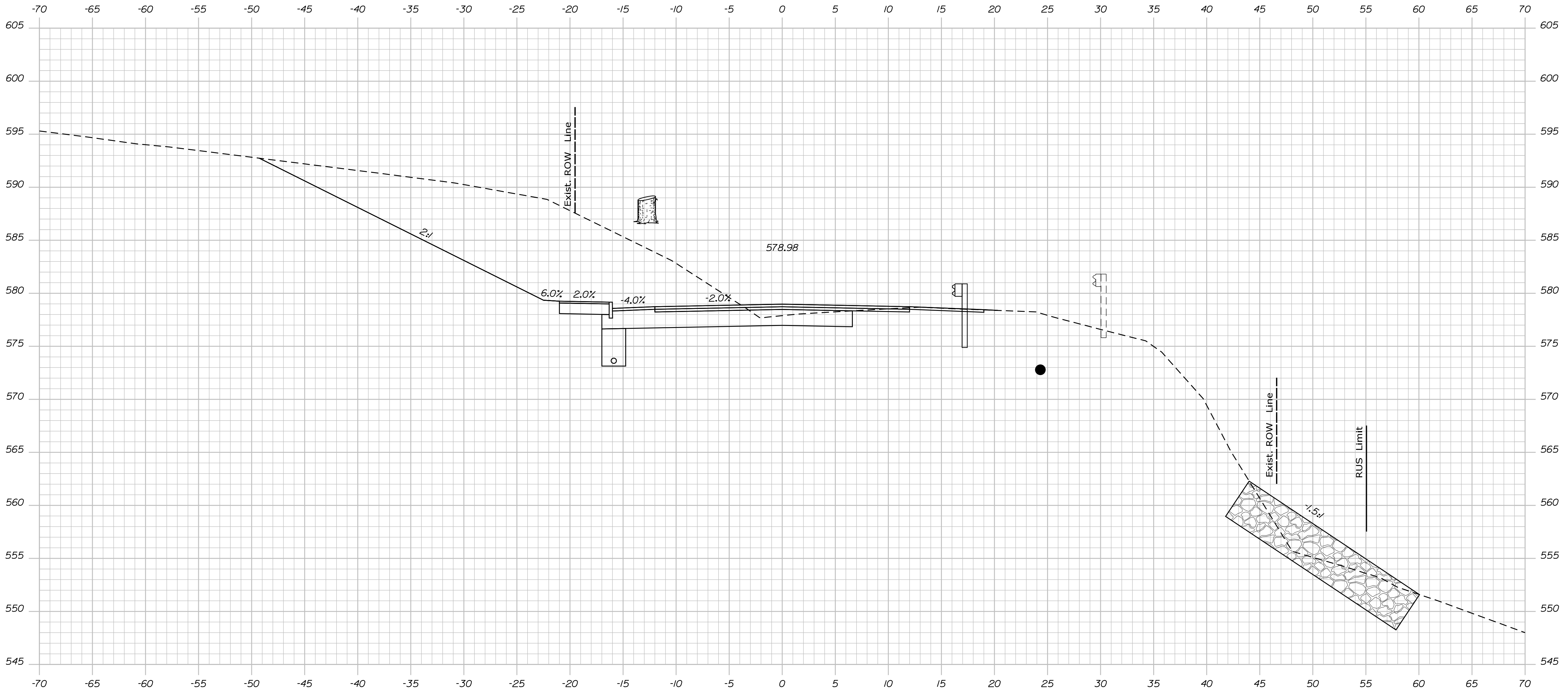

1029+50.00

Sta. 1029+50.00 to Sta. 1029+50.00

STATE OF MAINE
DEPARTMENT OF TRANSPORTATION
STP-1824(500)

WIN
18245.00
HIERARCHIC PLANS

PROJ. MANAGER	DATE
DESIGN DETAIL	
CHECKED/REVIEWED	
DESIGN DETAIL	
DESIGN DETAIL	
REVISIONS 1	
REVISIONS 2	
REVISIONS 3	
REVISIONS 4	
FIELD CHANGES	

KINGFIELD
ROUTE 16\27
CROSS SECTIONS

SHEET NUMBER
Xse
OF 175

Date: \$date\$

Username:

Division: HIGHWAY

Filename: ... \Bentley\ustrn\Xsect.dgn

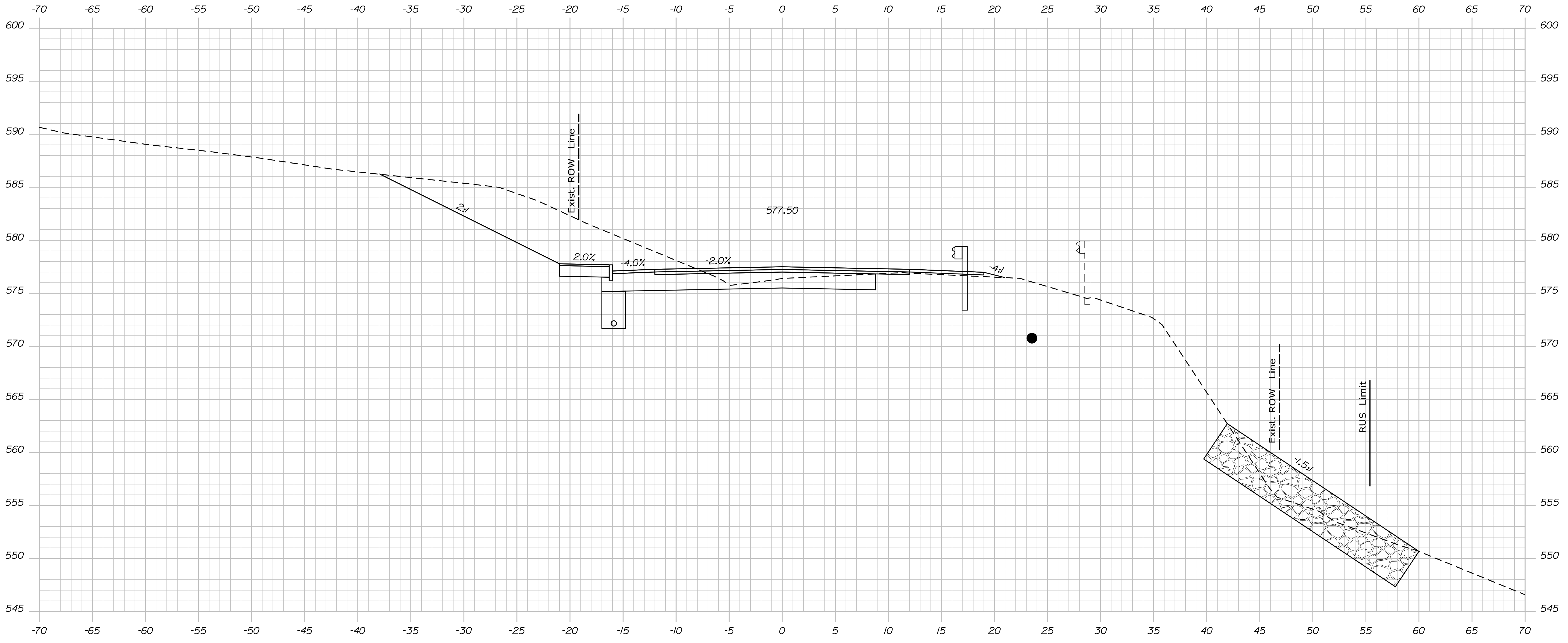

1030+00.00

Sta. 1030+00.00 to Sta. 1030+00.00

STATE OF MAINE
DEPARTMENT OF TRANSPORTATION
STP-1824(500)

SIGNATURE
P.E. NUMBER
DATE

PROJ. MANAGER	DATE
DESIGN DETAILED	
CHECKED/REVIEWED	
DESIGN DETAILED	
DESIGN DETAILED	
REVISIONS 1	
REVISIONS 2	
REVISIONS 3	
REVISIONS 4	
FIELD CHANGES	

**KINGFIELD
ROUTE 16\27
CROSS SECTIONS**

SHEET NUMBER
Xse
OF 175

WIN
18245.00
HIERARCHIC PLANS

Date: \$date\$

Username:

Division: HIGHWAY

Filename: ... \Bentley\ustrn\Xsect.dgn

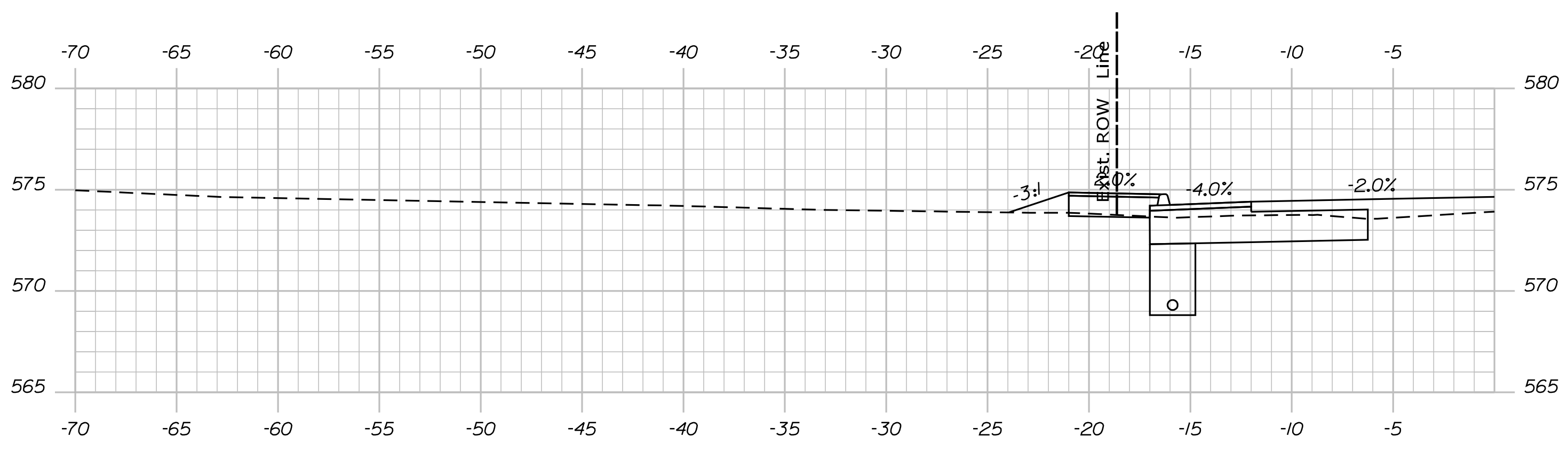

1030+94.00

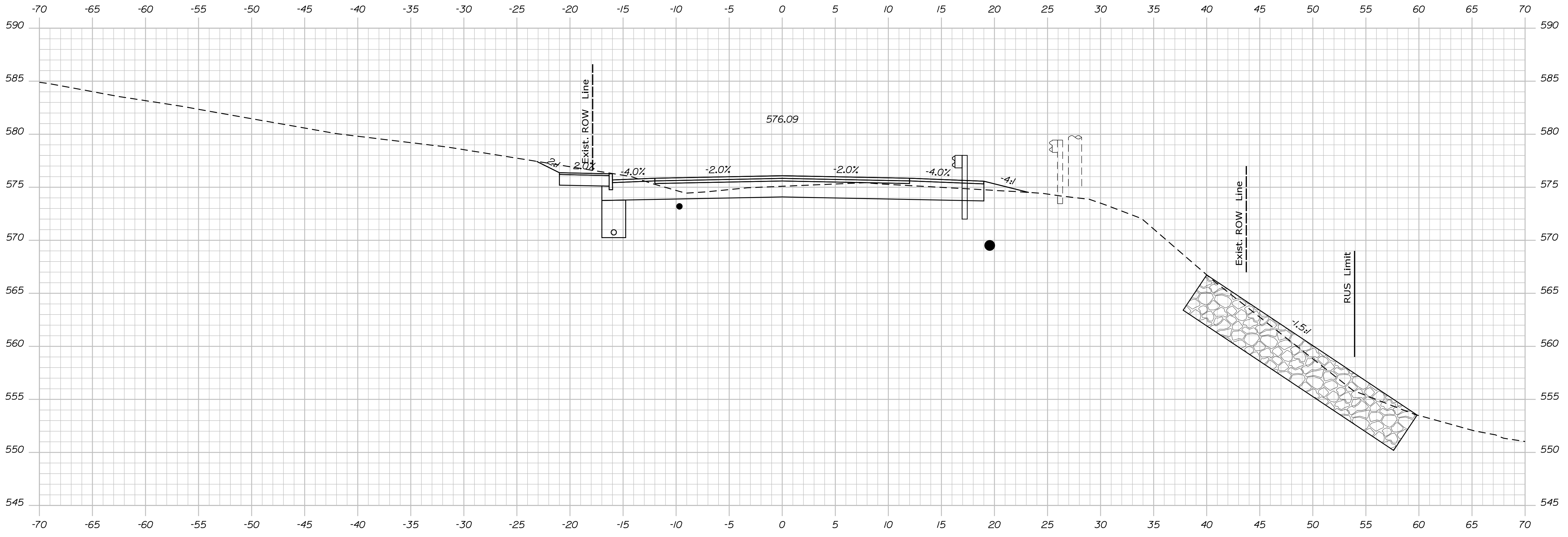

1030+50.00

STATE OF MAINE
DEPARTMENT OF TRANSPORTATION
STP-1824(500)

WIN
18245.00
HIERARCHIC PLANS

PROJ. MANAGER	DATE	BY	DATE
DESIGN DETAIL			
CHECKED/REVISED			
DESIGN DETAIL			
DESIGN DETAIL			
REVISIONS 1			
REVISIONS 2			
REVISIONS 3			
REVISIONS 4			
FIELD CHANGES			

KINGFIELD
ROUTE 16\27
CROSS SECTIONS

SHEET NUMBER
Xse
OF 175

Date: \$date\$

Username:

Division: HIGHWAY

Filename: ... \Bentley\ustrn\Xsect.dgn

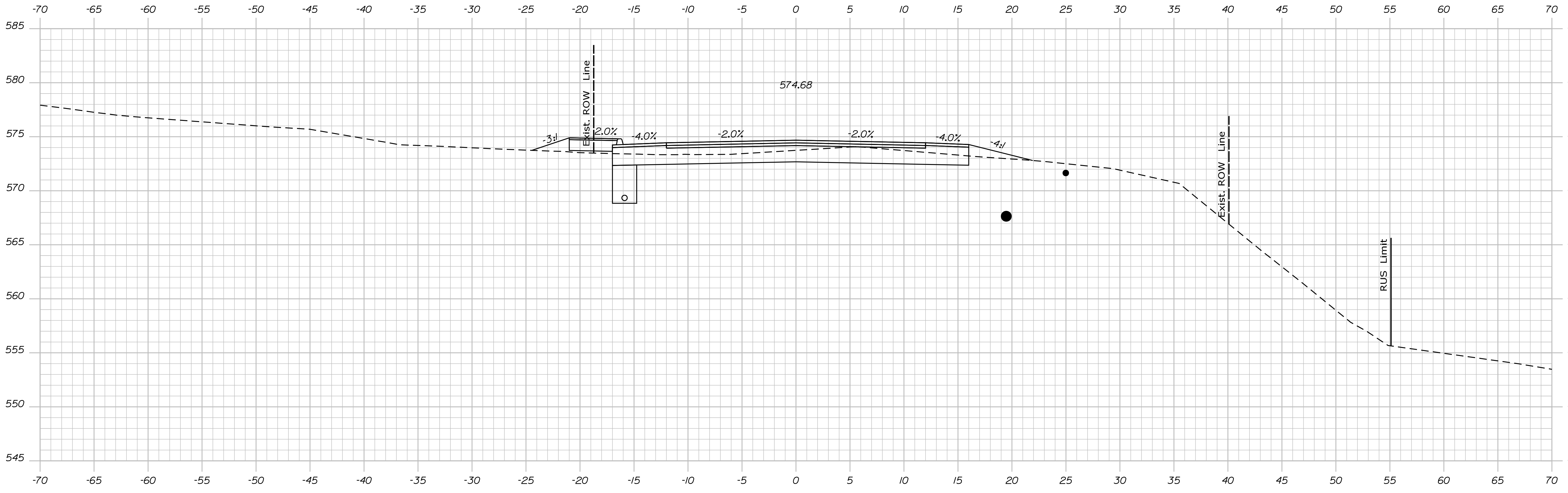
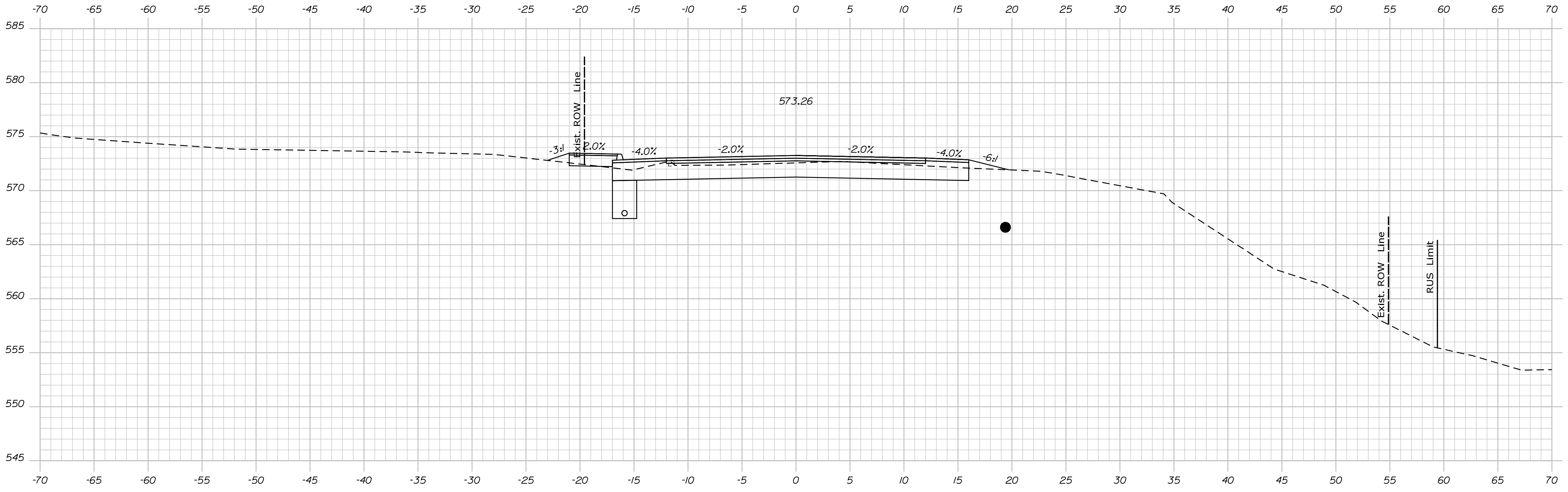

STATE OF MAINE
DEPARTMENT OF TRANSPORTATION
STP-1824(500)

WIN
18245.00
HIERARCHIC PLANS

PROJ. MANAGER	DATE
BY	DATE
DESIGN DETAIL	CHECKED/REVISED
DESIGN DETAIL	DESIGN DETAIL
REVISIONS 1	REVISIONS 2
REVISIONS 3	REVISIONS 4
FIELD CHANGES	

KINGFIELD
ROUTE 16\27
CROSS SECTIONS

SHEET NUMBER
Xse
OF 175

Date: \$date\$

Username:

Division: HIGHWAY

Filename: ... \Bentley\ustrn\Xsect.dgn

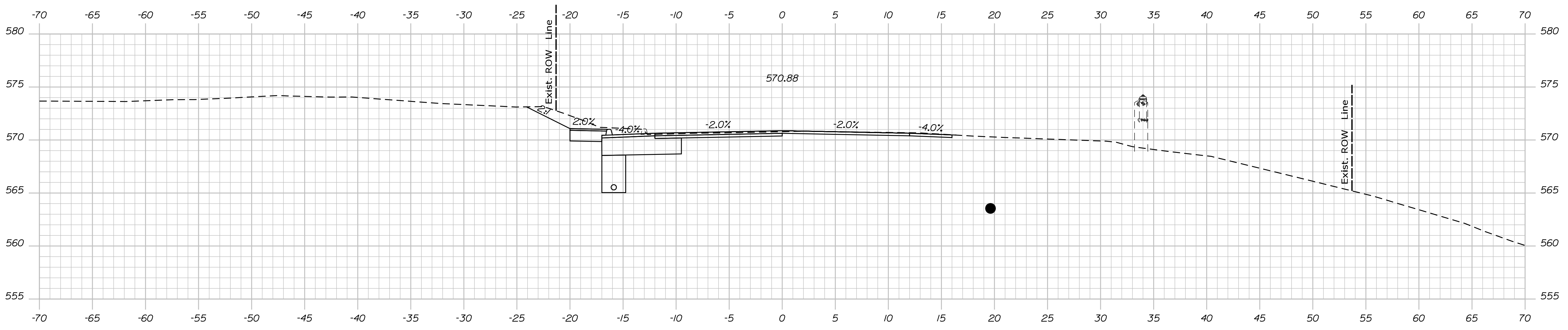

1032+50.00

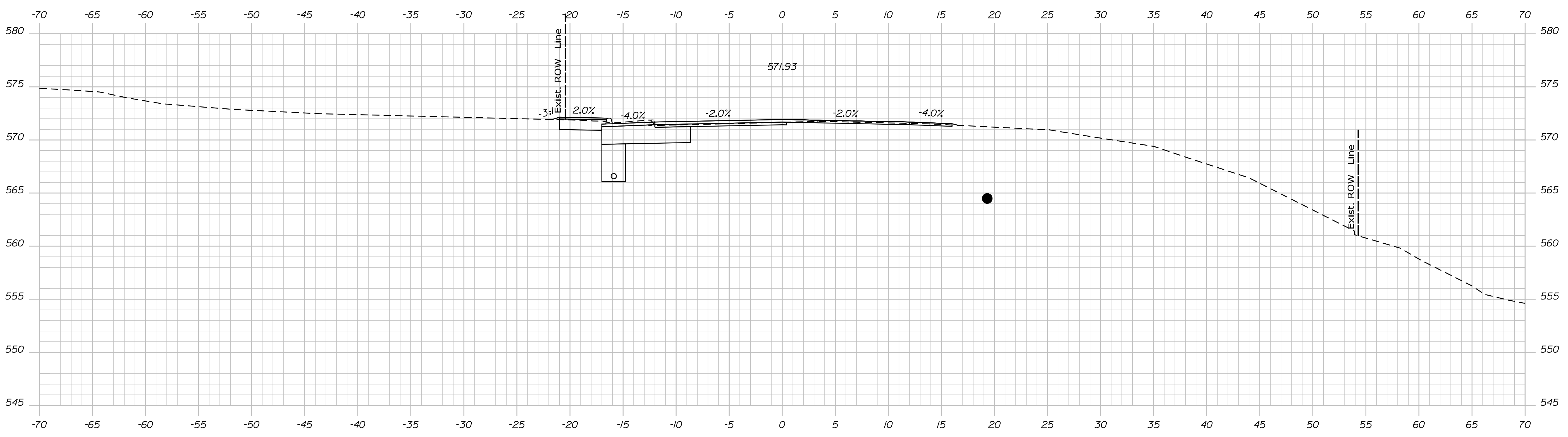

1032+00.00

STATE OF MAINE
 DEPARTMENT OF TRANSPORTATION
STP-1824(500)
 WIN
 18245.00
 HIERARCHIC PLANS

SIGNATURE
 P.E. NUMBER
 DATE

PROJ. MANAGER	DATE
DESIGN DETAILED	
CHECKED/REVIEWED	
DESIGN DETAILED	
DESIGN DETAILED	
REVISIONS 1	
REVISIONS 2	
REVISIONS 3	
REVISIONS 4	
FIELD CHANGES	

KINGFIELD
 ROUTE 16\27
 CROSS SECTIONS

SHEET NUMBER
Xse
 OF 175

Date: \$date\$

Username:

Division: HIGHWAY

Filename: ... \Bentley\ustrn\Xsect.dgn

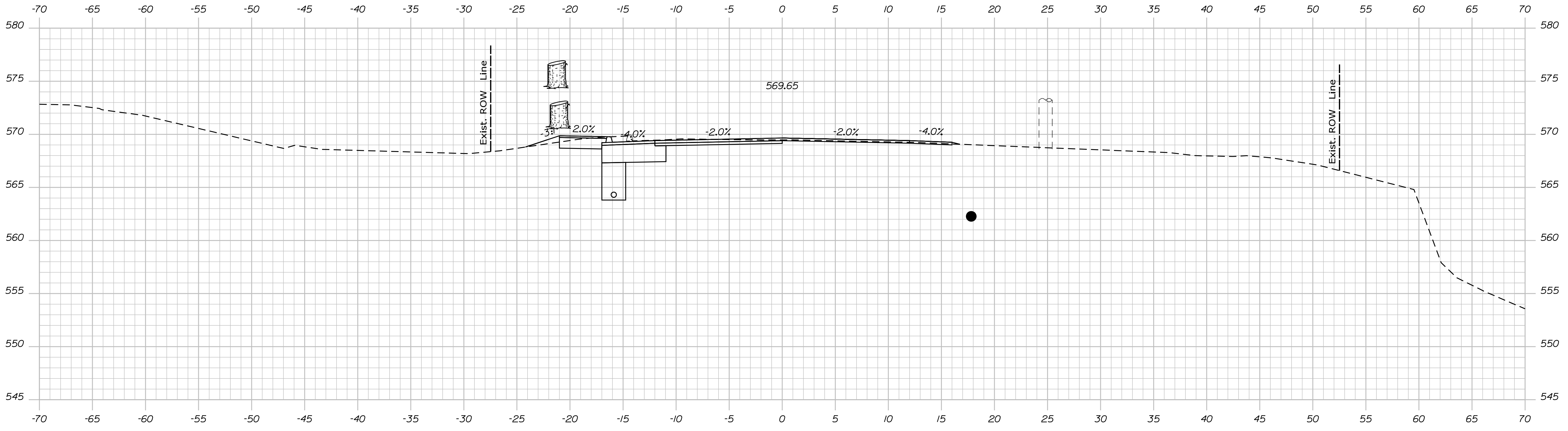

1033+50.00

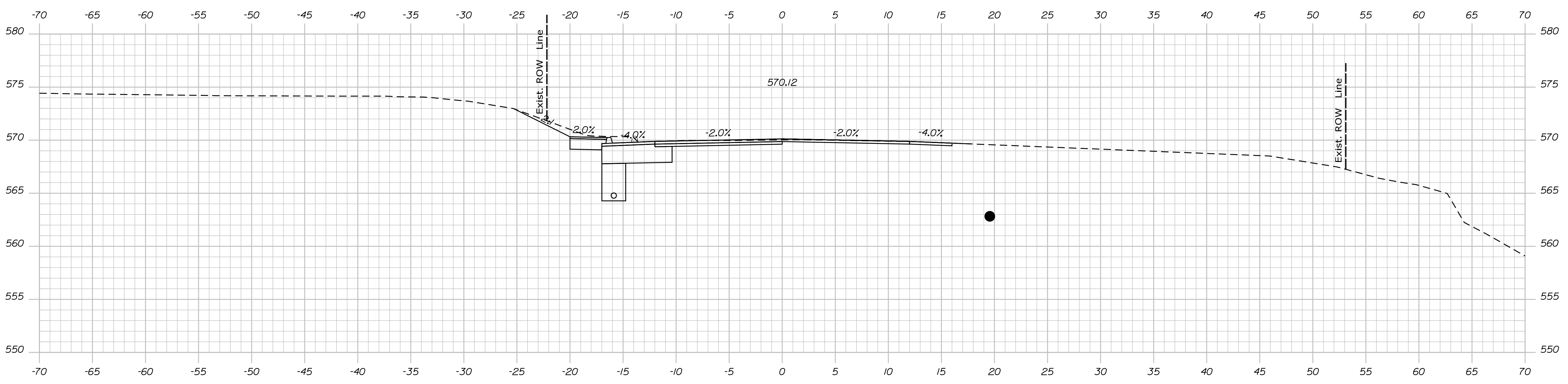

1033+00.00

STATE OF MAINE
DEPARTMENT OF TRANSPORTATION
STP-1824(500)
WIN
18245.00
HIERARCHIC PLANS

SIGNATURE
P.E. NUMBER
DATE

PROJ. MANAGER	DATE
DESIGN DETAILED	
CHECKED/REVIEWED	
DESIGN DETAILED	
DESIGN DETAILED	
REVISIONS 1	
REVISIONS 2	
REVISIONS 3	
REVISIONS 4	
FIELD CHANGES	

KINGFIELD
ROUTE 16\27
CROSS SECTIONS

SHEET NUMBER
Xse
OF 175

Date: \$date\$

Username:

Division: HIGHWAY

Filename: ... \Bentley\ustrn\Xsect.dgn

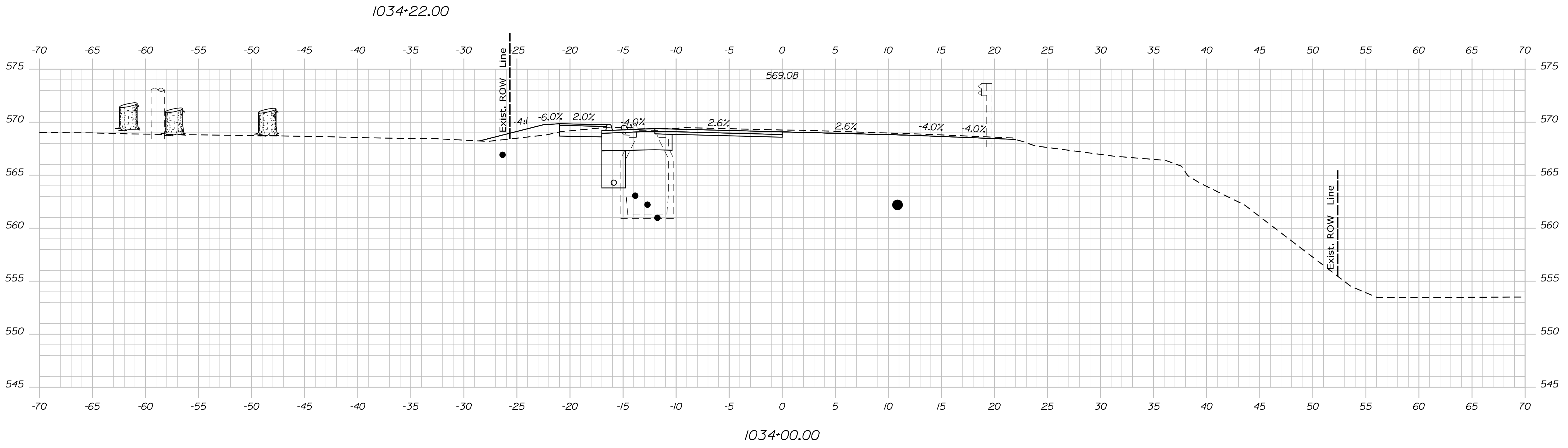
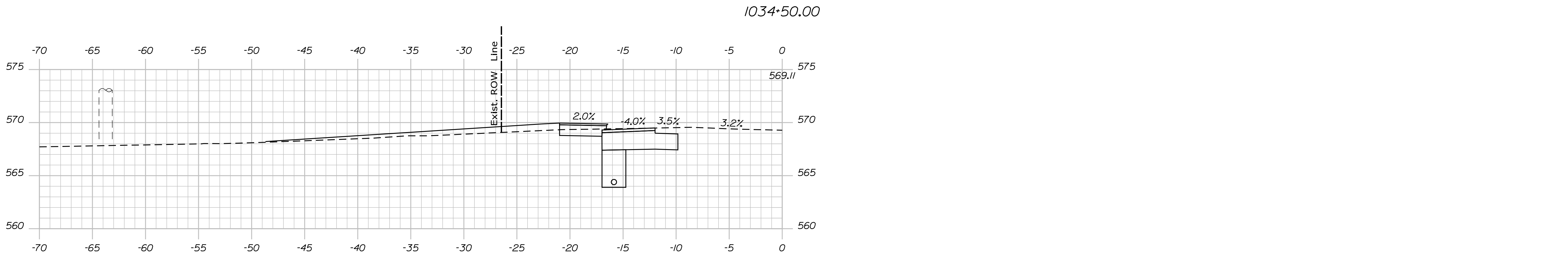
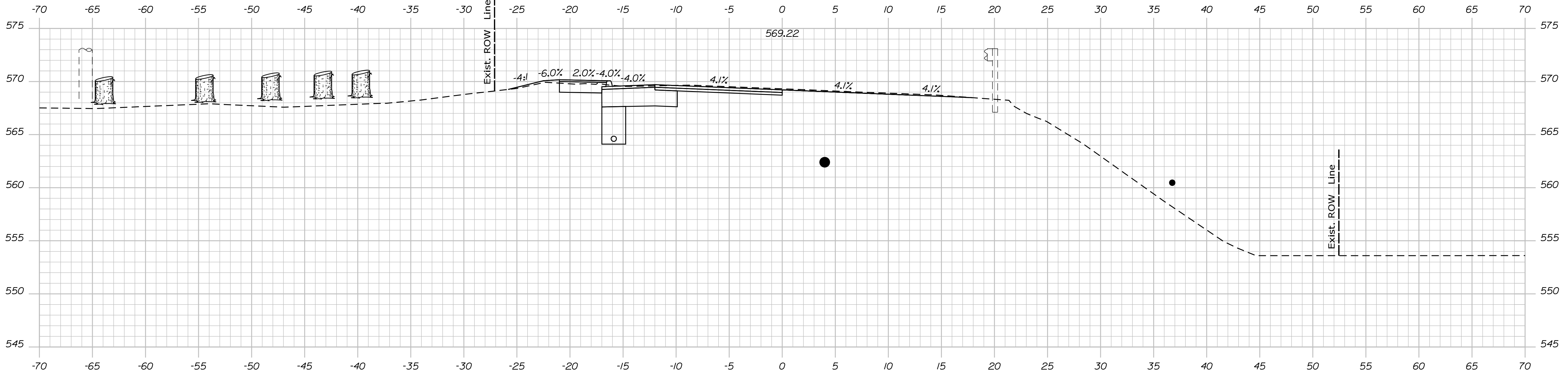

STATE OF MAINE
DEPARTMENT OF TRANSPORTATION
STP-1824(500)
WIN
18245.00
HIERARCHIC PLANS

PROJ. MANAGER	DATE
DESIGN DETAIL	BY
CHECKED/REVISED	DATE
DESIGN DETAIL	SIGNATURE
DESIGN DETAIL	P.E. NUMBER
REVISIONS 1	DATE
REVISIONS 2	
REVISIONS 3	
REVISIONS 4	
FIELD CHANGES	

PROJ. MANAGER	DATE
DESIGN DETAIL	BY
CHECKED/REVISED	DATE
DESIGN DETAIL	SIGNATURE
DESIGN DETAIL	P.E. NUMBER
REVISIONS 1	DATE
REVISIONS 2	
REVISIONS 3	
REVISIONS 4	
FIELD CHANGES	

KINGFIELD
ROUTE 16\27
CROSS SECTIONS

SHEET NUMBER
Xse
OF 175

Date: \$date\$

Username:

Division: HIGHWAY

Filename: ... \Bentley\ustrn\Xsect.dgn

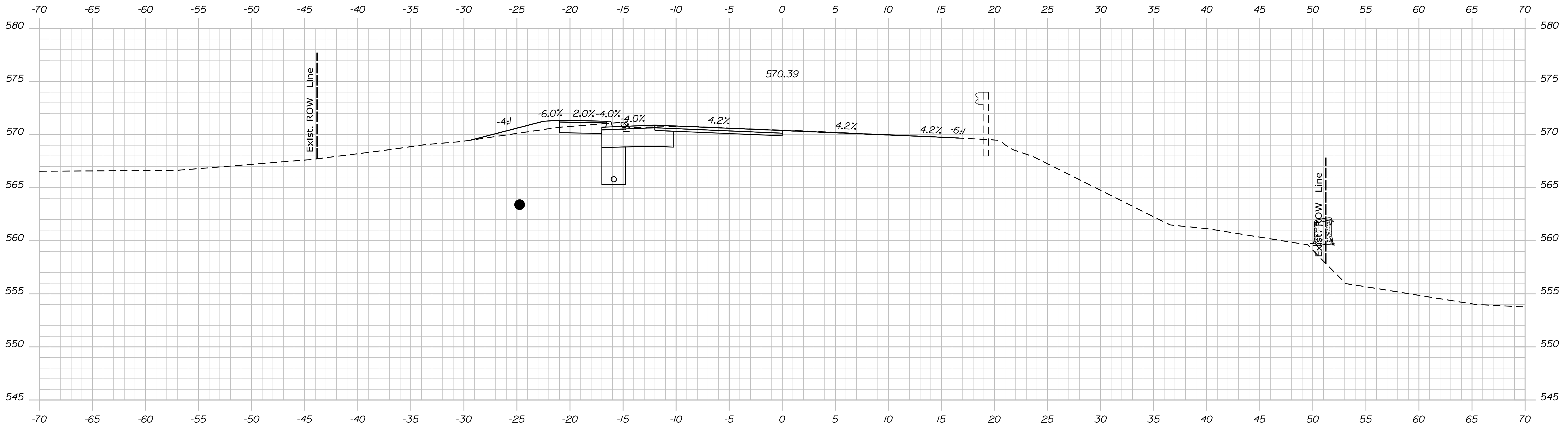

1035+50.00

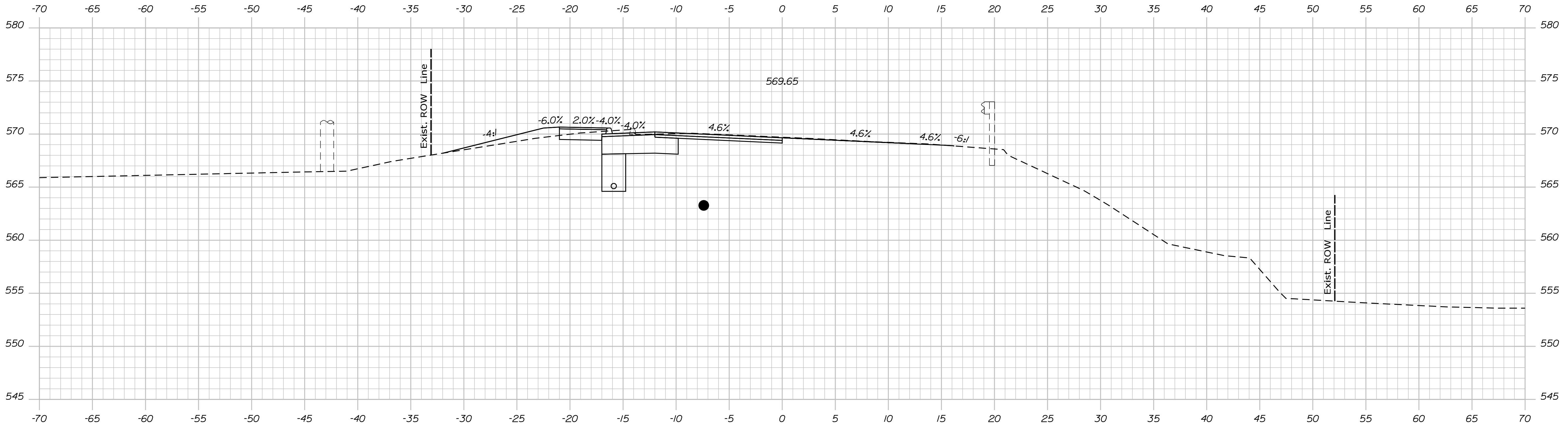

1035+00.00

STATE OF MAINE
DEPARTMENT OF TRANSPORTATION
STP-1824(500)
WIN
18245.00
HIERARCHIC PLANS

SIGNATURE
P.E. NUMBER
DATE

PROJ. MANAGER	DATE
DESIGN DETAILED	
CHECKED/REVISED	
DESIGN DETAILED	
DESIGN DETAILED	
REVISIONS 1	
REVISIONS 2	
REVISIONS 3	
REVISIONS 4	
FIELD CHANGES	

KINGFIELD
ROUTE 16\27
CROSS SECTIONS

SHEET NUMBER
Xse
OF 175

Date: \$date\$

Username:

Division: HIGHWAY

Filename: ... \Bentley\ustrn\Xsect.dgn

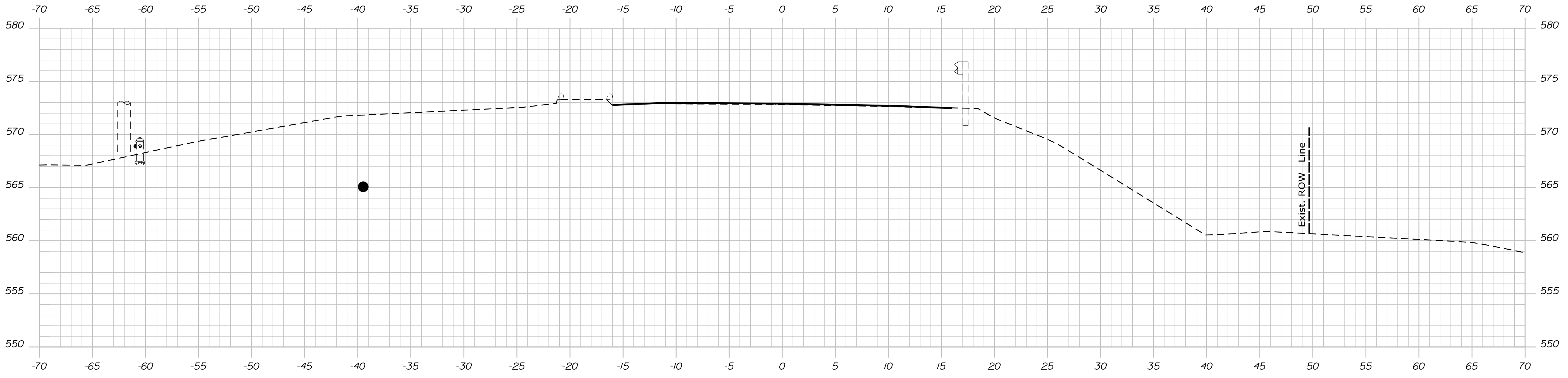

1036+50.00

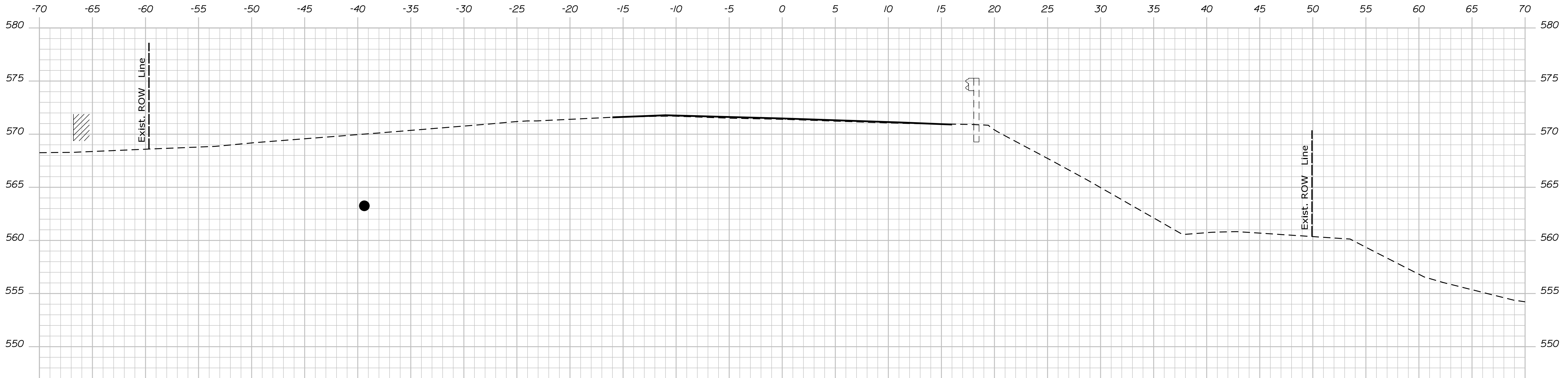

1036+00.00

STATE OF MAINE
DEPARTMENT OF TRANSPORTATION
STP-1824(500)

WIN
18245.00
HIERARCHIC PLANS

PROJ. MANAGER	DATE
DESIGN DETAILED	
CHECKED/REVIEWED	
DESIGN DETAILED	
DESIGN DETAILED	
REVISIONS 1	
REVISIONS 2	
REVISIONS 3	
REVISIONS 4	
FIELD CHANGES	

KINGFIELD
ROUTE 16\27
CROSS SECTIONS

SHEET NUMBER
Xse
OF 175

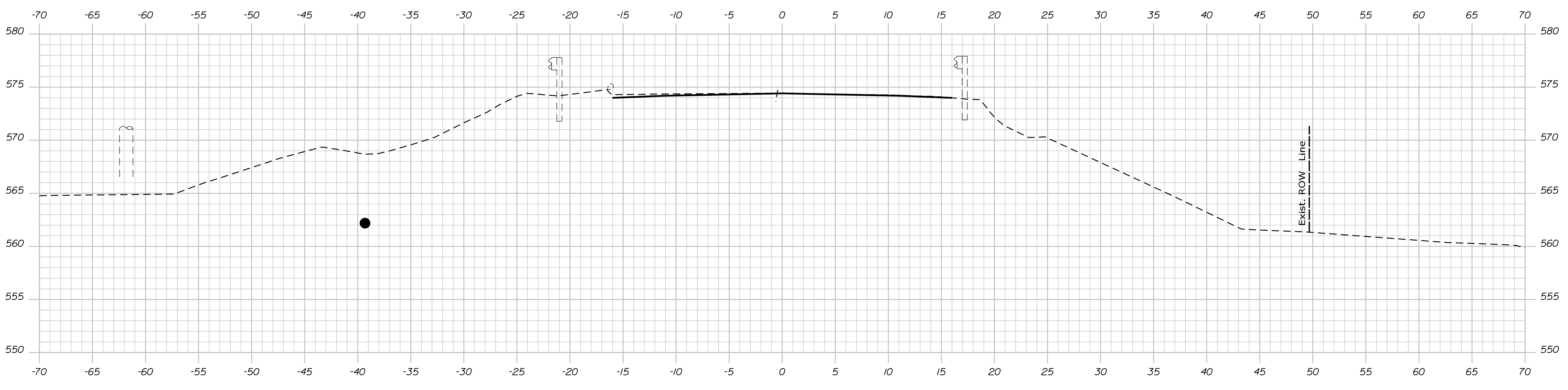
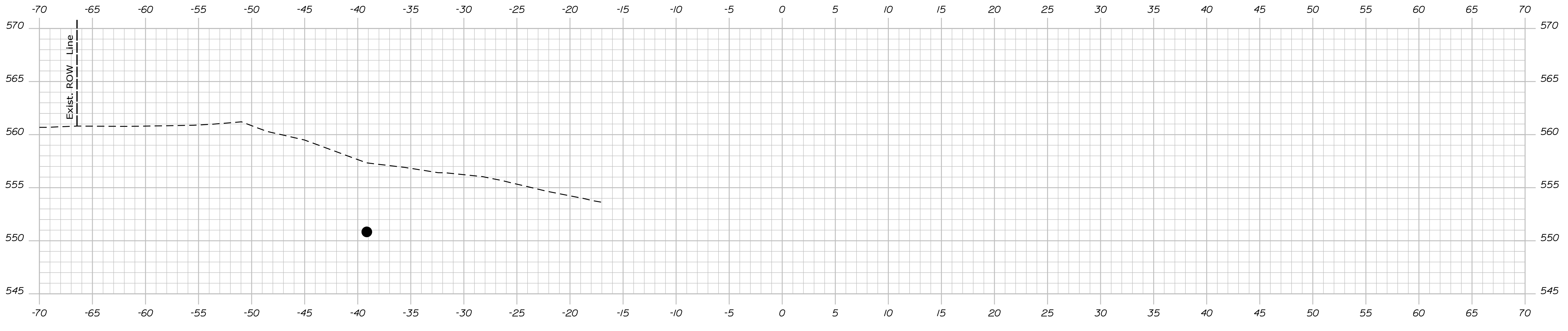
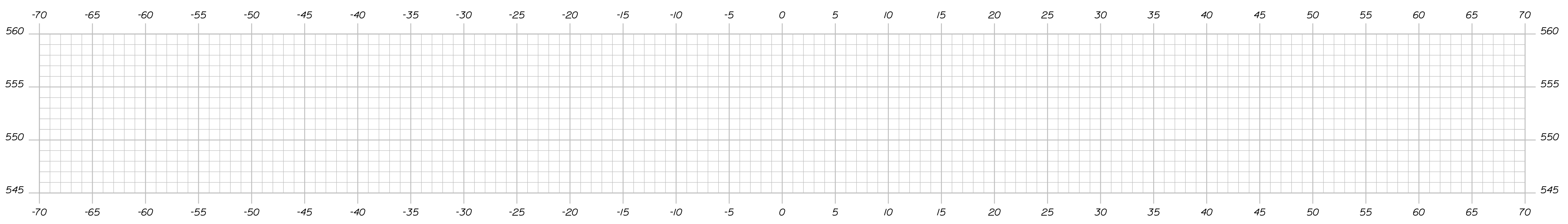

STATE OF MAINE
DEPARTMENT OF TRANSPORTATION
STP-1824(500)
WIN
18245.00
HIERARCHIC PLANS

PROJ. MANAGER	DATE	BY	DATE
DESIGN DETAILED			
CHECKED/REVIEWED			
DESIGN DETAILED			
DESIGN DETAILED			
REVISIONS 1			
REVISIONS 2			
REVISIONS 3			
REVISIONS 4			
FIELD CHANGES			

KINGFIELD
ROUTE 16\27
CROSS SECTIONS

SHEET NUMBER
Xse
OF 175

Date: \$date\$

Username:

Division: HIGHWAY

Filename: ... \Bentley\ustrn\Xsect.dgn

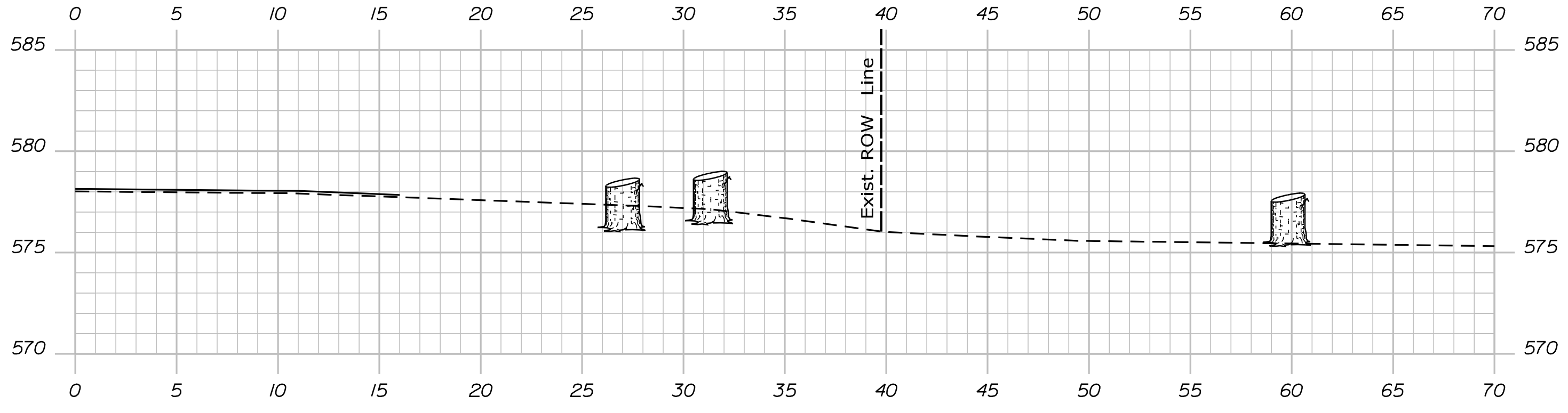

1039+22.00

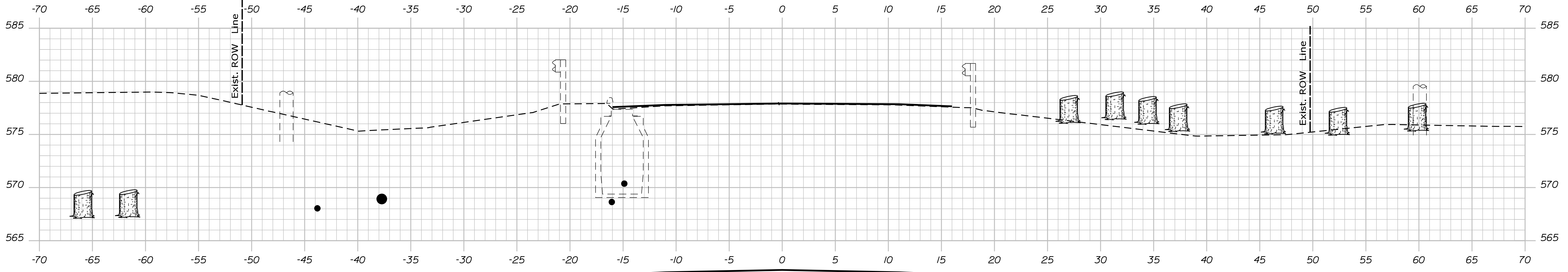

1039+00.00

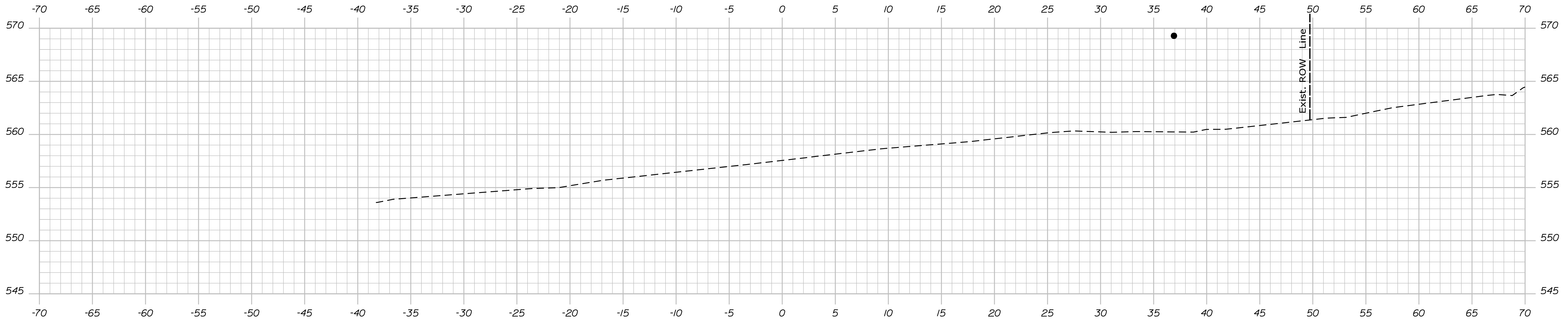

1038+50.00

STATE OF MAINE
DEPARTMENT OF TRANSPORTATION
STP-1824(500)

WIN
18245.00
HIERARCHIC PLANS

PROJ. MANAGER	BY	DATE

SIGNATURE	P.E. NUMBER	DATE

DESIGN DETAILED	CHECKED/REVIEWED	DESIGN DETAILED	DESIGN DETAILED	REVISIONS 1	REVISIONS 2	REVISIONS 3	REVISIONS 4	FIELD CHANGES

KINGFIELD
ROUTE 16\27
CROSS SECTIONS

SHEET NUMBER
Xse
OF 175

Date: \$date\$

Username:

Division: HIGHWAY

Filename: ... \Bentley\ustrn\Xsect.dgn

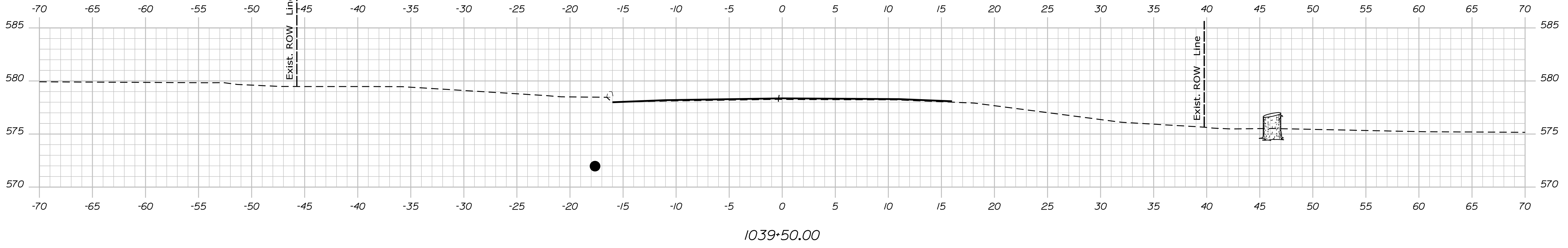
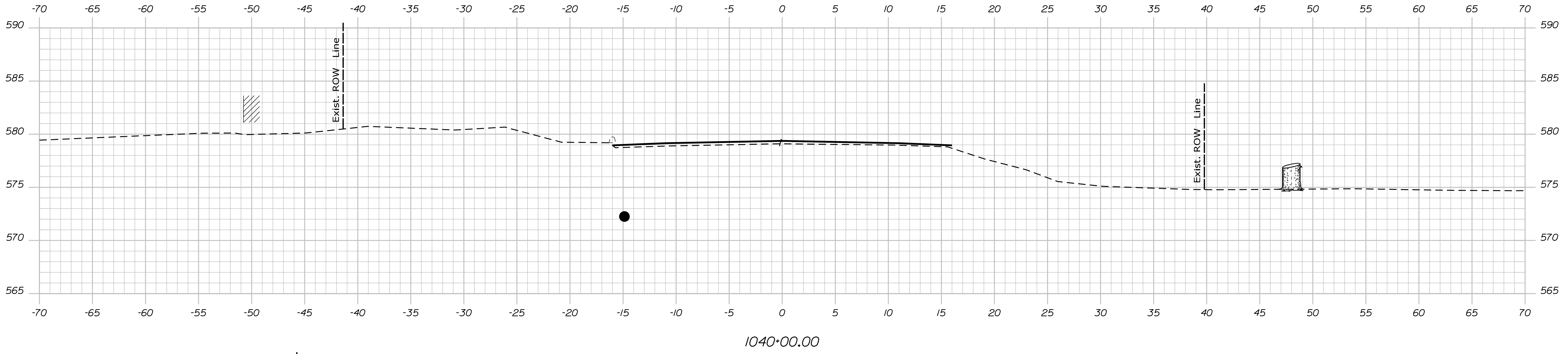
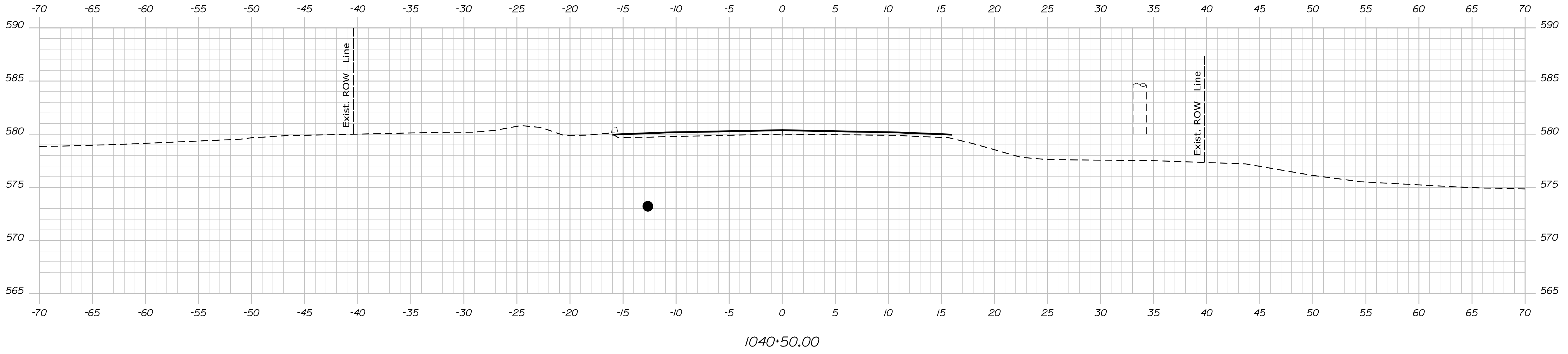

STATE OF MAINE
DEPARTMENT OF TRANSPORTATION
STP-1824(500)
WIN
18245.00
HIERARCHIC PLANS

SIGNATURE	DATE
P.E. NUMBER	

PROJ. MANAGER	BY	DATE
DESIGN/DETAILED		
CHECKED/REVIEWED		
DESIGN/DETAILED		
DESIGN/DETAILED		
REVISIONS 1		
REVISIONS 2		
REVISIONS 3		
REVISIONS 4		
FIELD CHANGES		

KINGFIELD
ROUTE 16\27
CROSS SECTIONS

SHEET NUMBER
Xse
OF 175

Date: \$date\$

Username:

Division: HIGHWAY

Filename: ... \Bentley\ustrn\Xsect.dgn

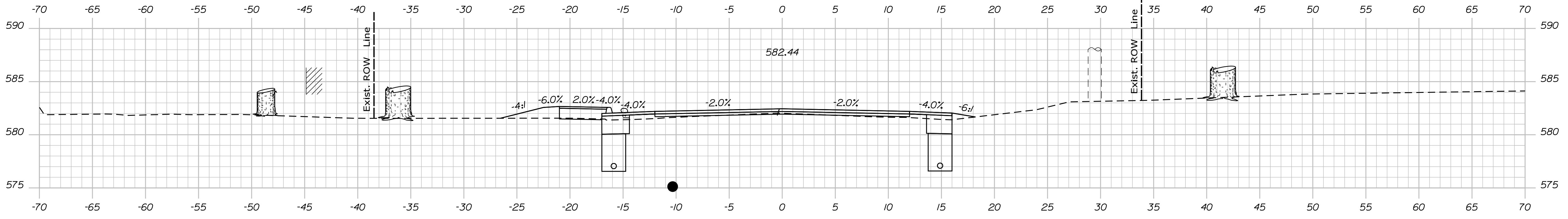

1041+50.00

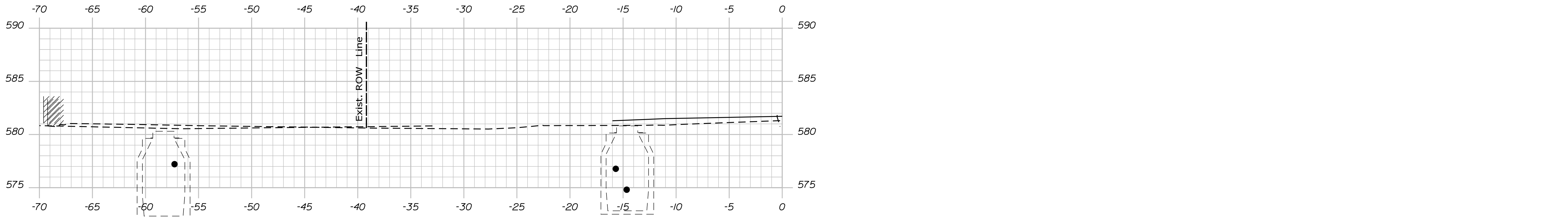

1041+13.00

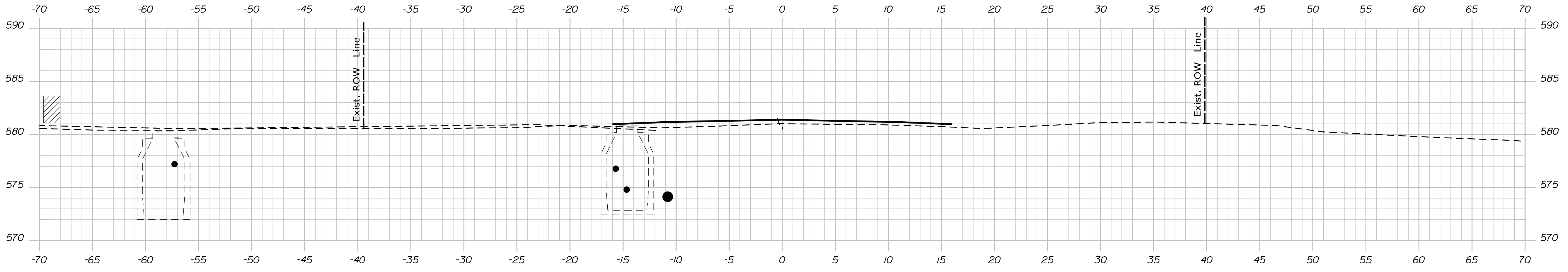

1041+00.00

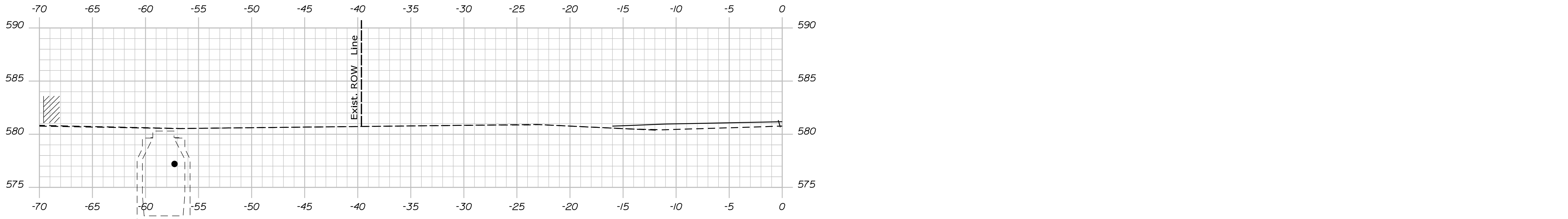

1040+89.00

STATE OF MAINE
DEPARTMENT OF TRANSPORTATION
STP-1824(500)
WIN
18245.00
HIERARCHIC PLANS

PROJ. MANAGER	DATE
CHECKED/REVIEWED	SIGNATURE
DESIGN DETAILER	P.E. NUMBER
DESIGN DETAILER	DATE
REVISIONS 1	
REVISIONS 2	
REVISIONS 3	
REVISIONS 4	
FIELD CHANGES	

PROJ. MANAGER \$PROJMANAGER\$
BY
DATE

KINGFIELD
ROUTE 16\27
CROSS SECTIONS

SHEET NUMBER
Xse
OF 175

Date: \$date\$

Username:

Division: HIGHWAY

Filename: ... \Bentley\ustrn\Xsect.dgn

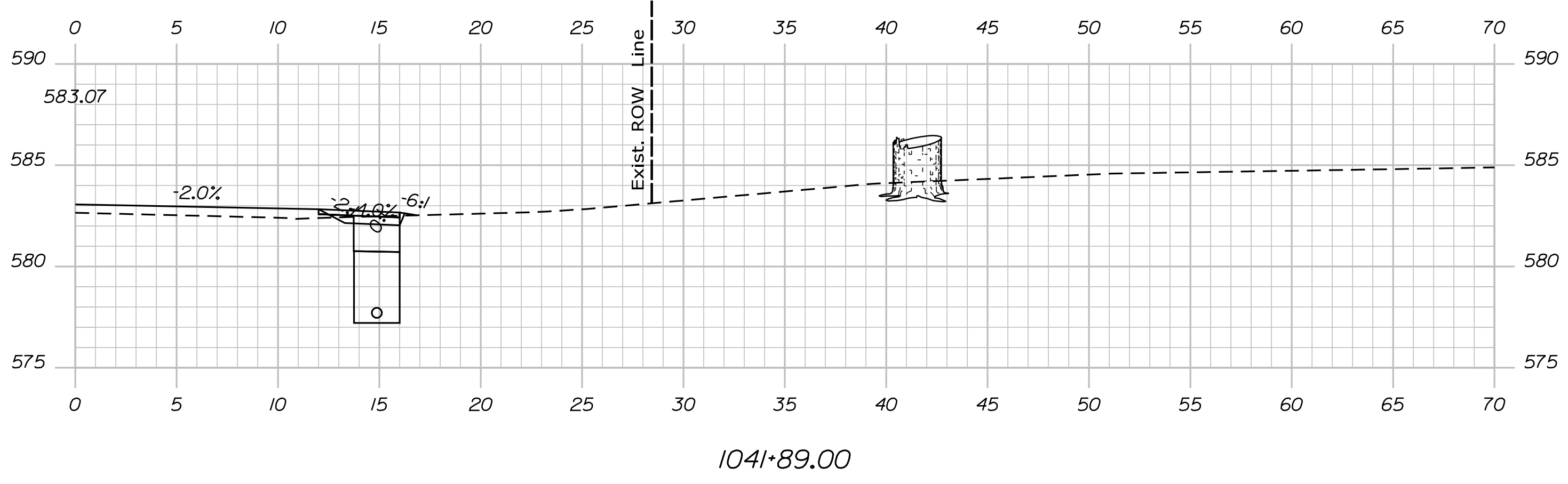
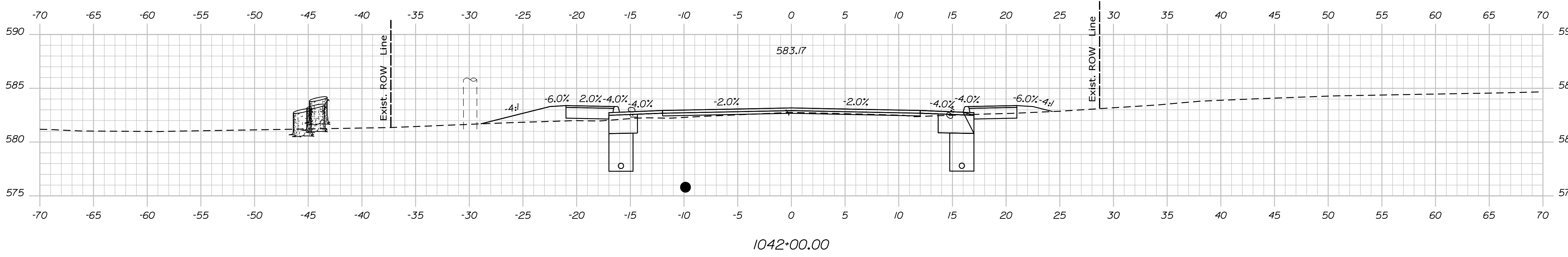
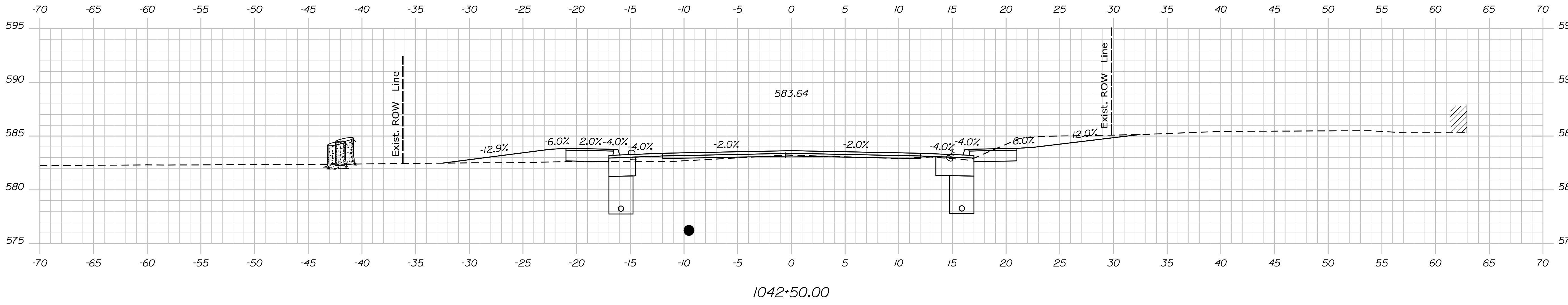
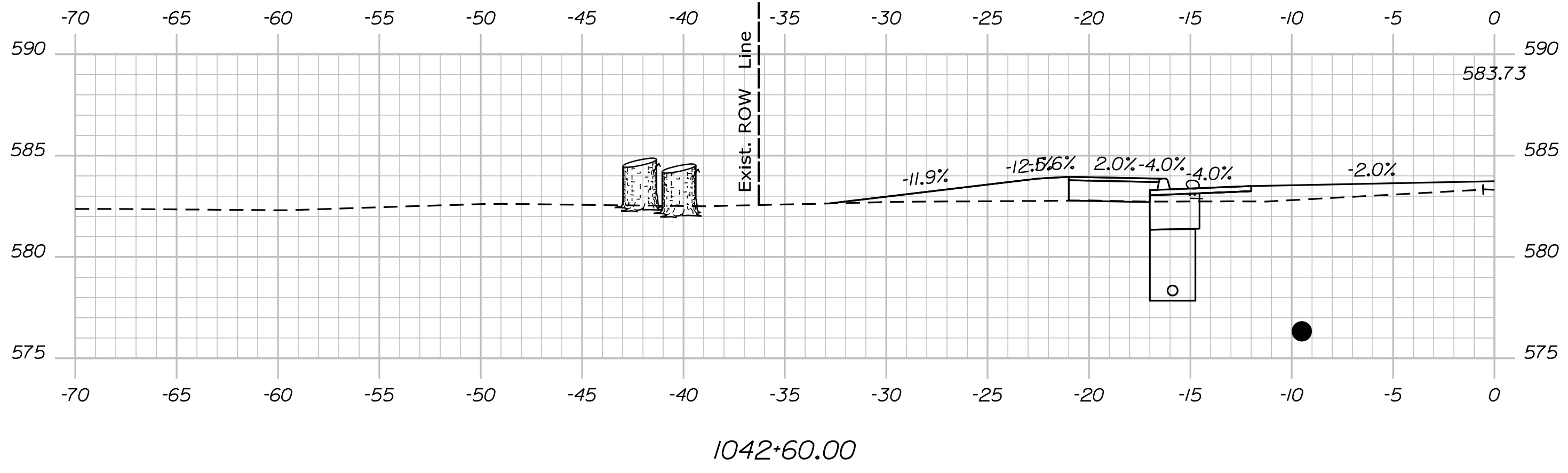

STATE OF MAINE
DEPARTMENT OF TRANSPORTATION
STP-1824(500)
WIN
18245.00
HIERARCHIC PLANS

SIGNATURE
P.E. NUMBER
DATE

PROJ. MANAGER	DATE
DESIGN DETAILED	
CHECKED/REVIEWED	
DESIGN DETAILED	
DESIGN DETAILED	
REVISIONS 1	
REVISIONS 2	
REVISIONS 3	
REVISIONS 4	
FIELD CHANGES	

KINGFIELD
ROUTE 16\27
CROSS SECTIONS

SHEET NUMBER
Xse
OF 175

Date: \$date\$

Username:

Division: HIGHWAY

Filename: ... \Bentley\ustrn\Xsect.dgn

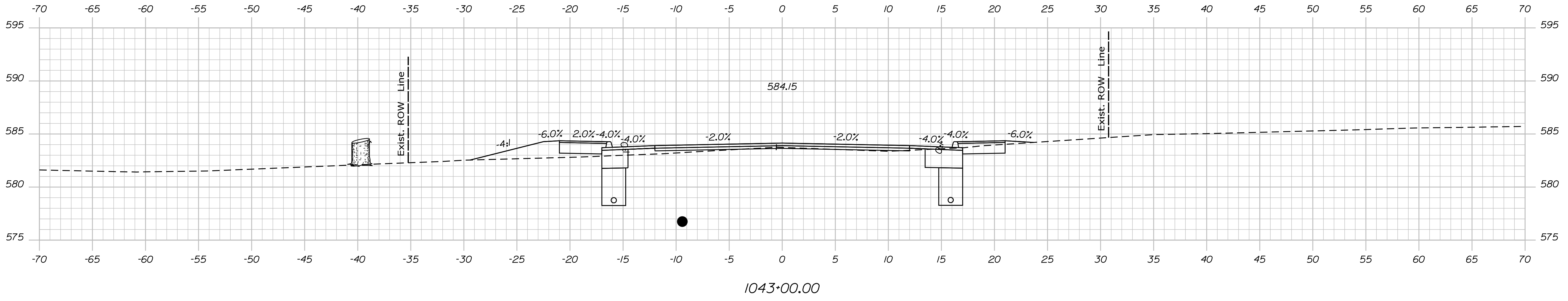
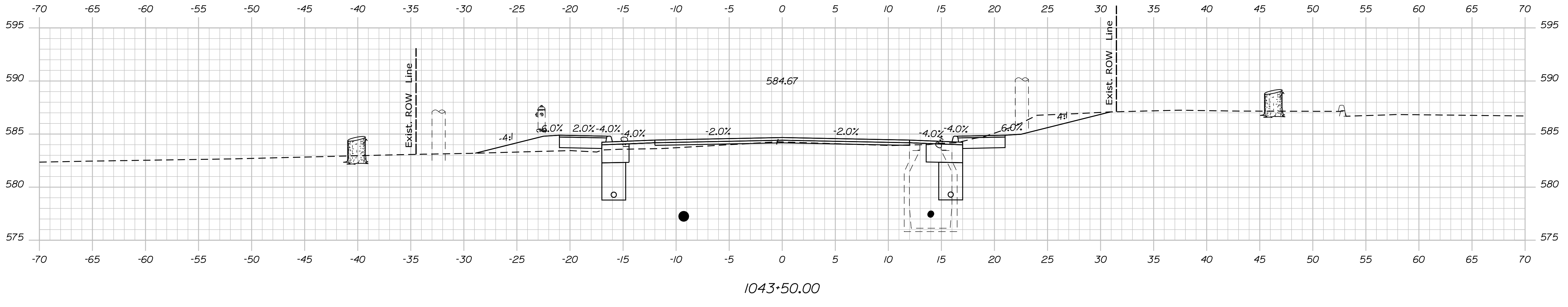
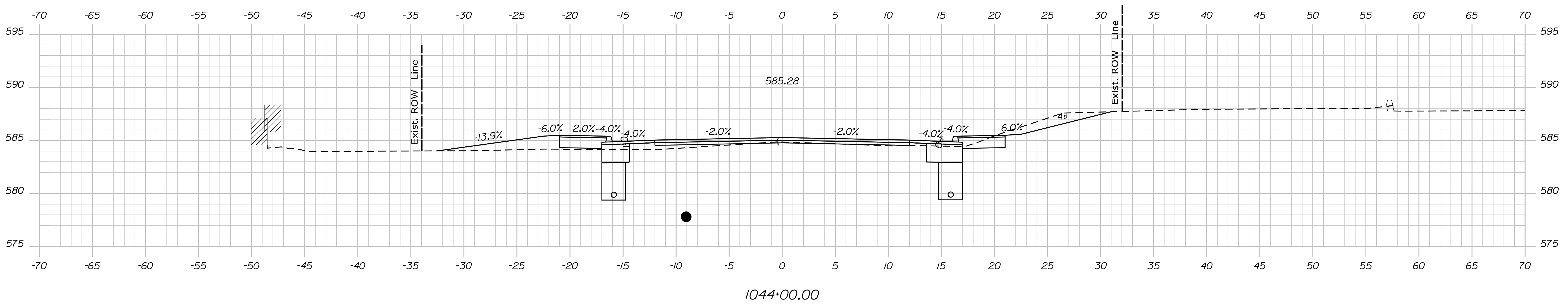

STATE OF MAINE
DEPARTMENT OF TRANSPORTATION
STP-1824(500)
WIN
18245.00
HIERARCHIC PLANS

SIGNATURE
P.E. NUMBER
DATE

PROJ. MANAGER	DATE
DESIGN/DETAILED	
CHECKED/REVIEWED	
DESIGN/DETAILED	
DESIGN/DETAILED	
REVISIONS 1	
REVISIONS 2	
REVISIONS 3	
REVISIONS 4	
FIELD CHANGES	

KINGFIELD
ROUTE 16\27
CROSS SECTIONS

SHEET NUMBER
Xse
OF 175

Date: \$date\$

Username:

Division: HIGHWAY

Filename: ... \Bentley\ustrn\Xsect.dgn

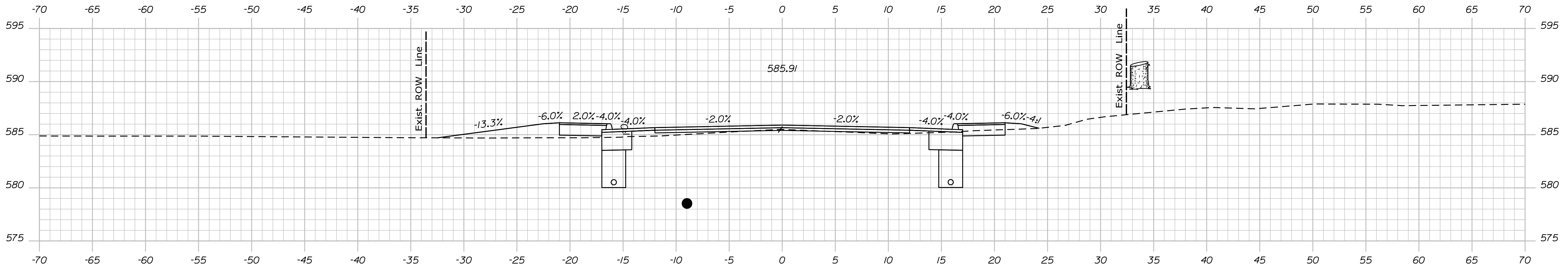

1044+50.00

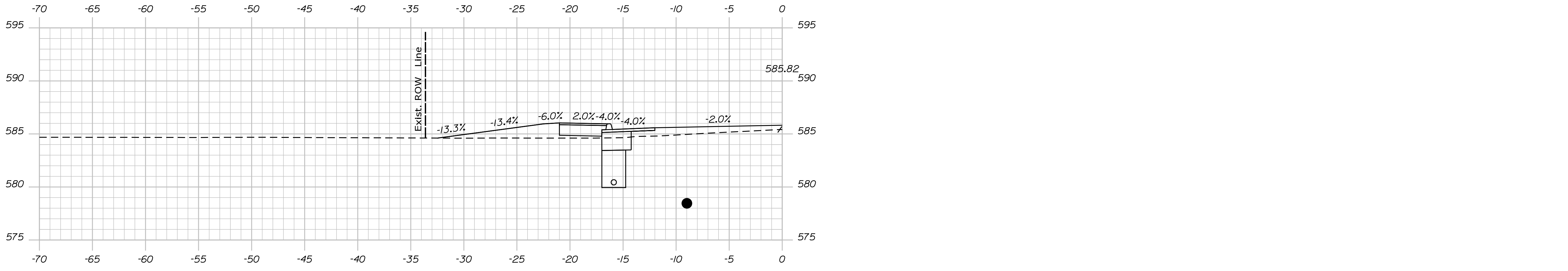

1044+43.00

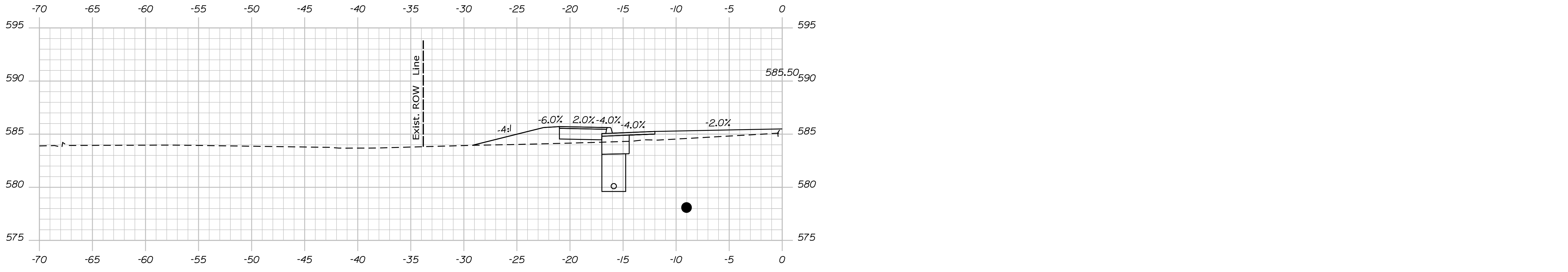

1044+16.00

STATE OF MAINE
DEPARTMENT OF TRANSPORTATION
STP-1824(500)
WIN
18245.00
HIERARCHIC PLANS

SIGNATURE
P.E. NUMBER
DATE

PROJ. MANAGER	DATE
DESIGN/DETAILED	
CHECKED/REVIEWED	
DESIGN/DETAILED	
DESIGN/DETAILED	
REVISIONS 1	
REVISIONS 2	
REVISIONS 3	
REVISIONS 4	
FIELD CHANGES	

KINGFIELD
ROUTE 16\27
CROSS SECTIONS

SHEET NUMBER
Xse
OF 175

Date: \$date\$

Username:

Division: HIGHWAY

Filename: ... \Bentley\ustrn\Xsect.dgn

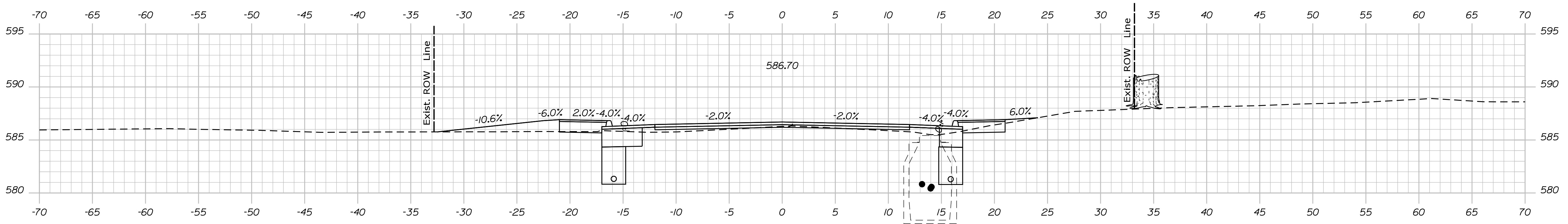

1045+50.00

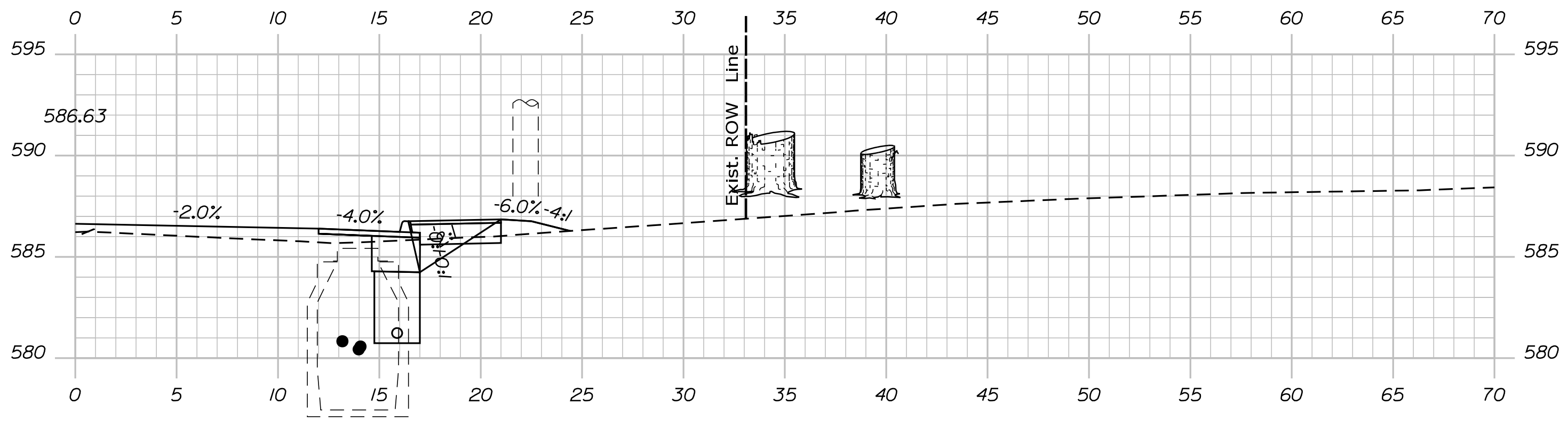

1045+36.00

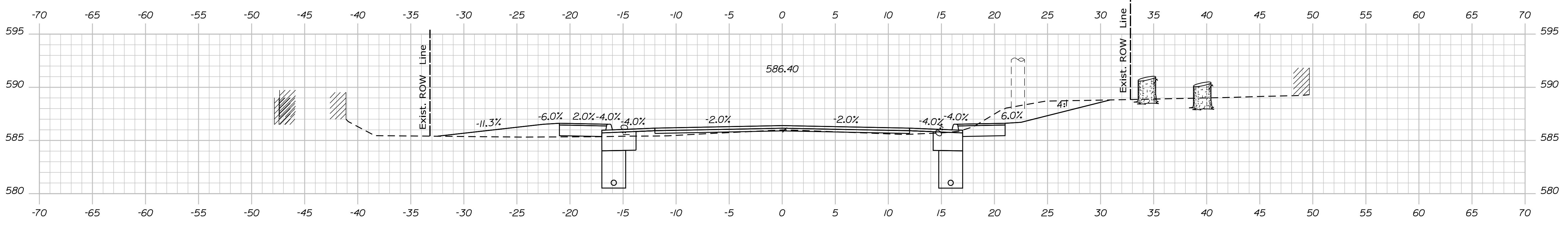

1045+00.00

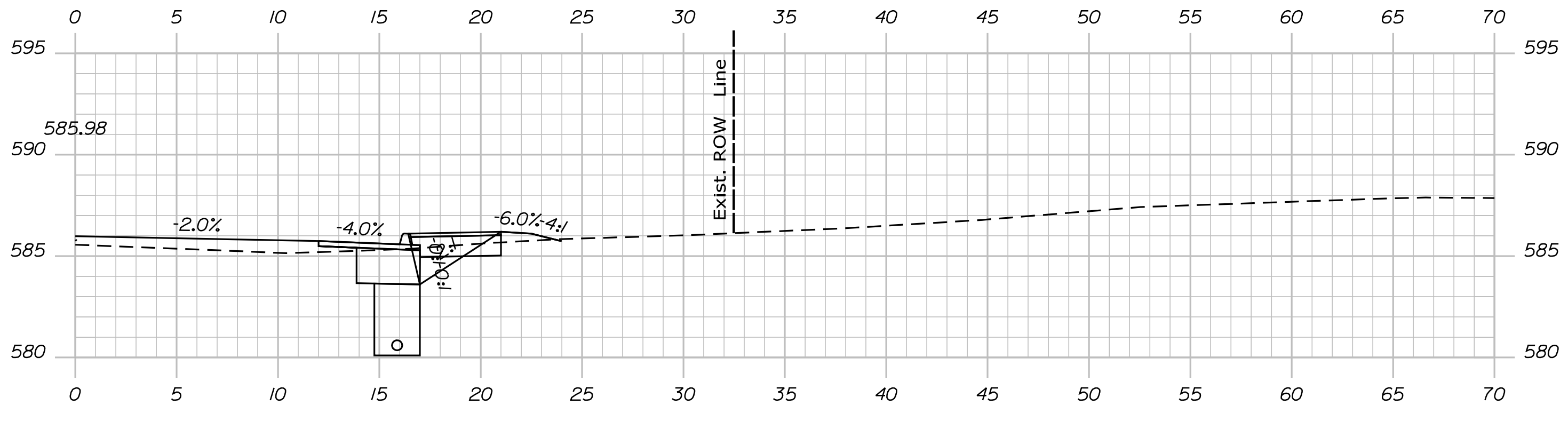

1044+56.00

STATE OF MAINE
 DEPARTMENT OF TRANSPORTATION
 STP-1824(500)
 WIN
 18245.00
 HIGHWAY PLANS

PROJ. MANAGER	DATE
DESIGN DETAILED	
CHECKED/REVIEWED	
DESIGN DETAILED	
DESIGN DETAILED	
REVISIONS 1	
REVISIONS 2	
REVISIONS 3	
REVISIONS 4	
FIELD CHANGES	

KINGFIELD
 ROUTE 16\27
 CROSS SECTIONS

SHEET NUMBER
Xse
 OF 175

Date: \$date\$

Username:

Division: HIGHWAY

Filename: ... \Bentley\ustrn\Xsect.dgn

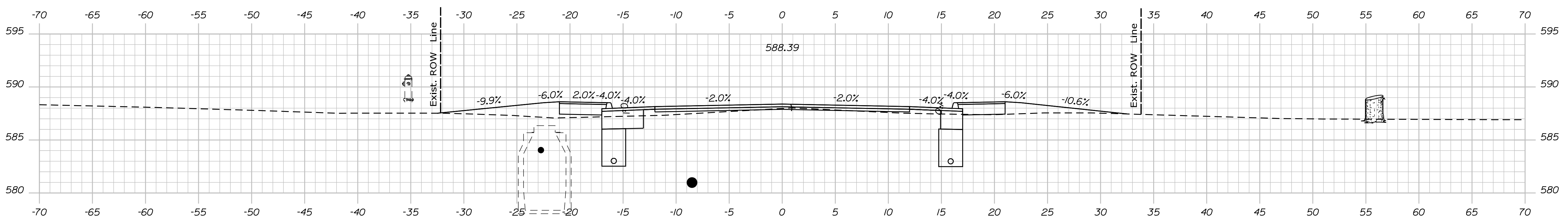

1047+00.00

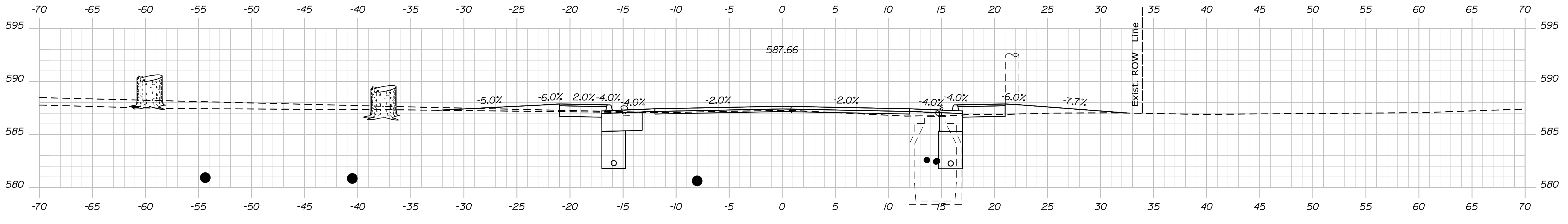

1046+50.00

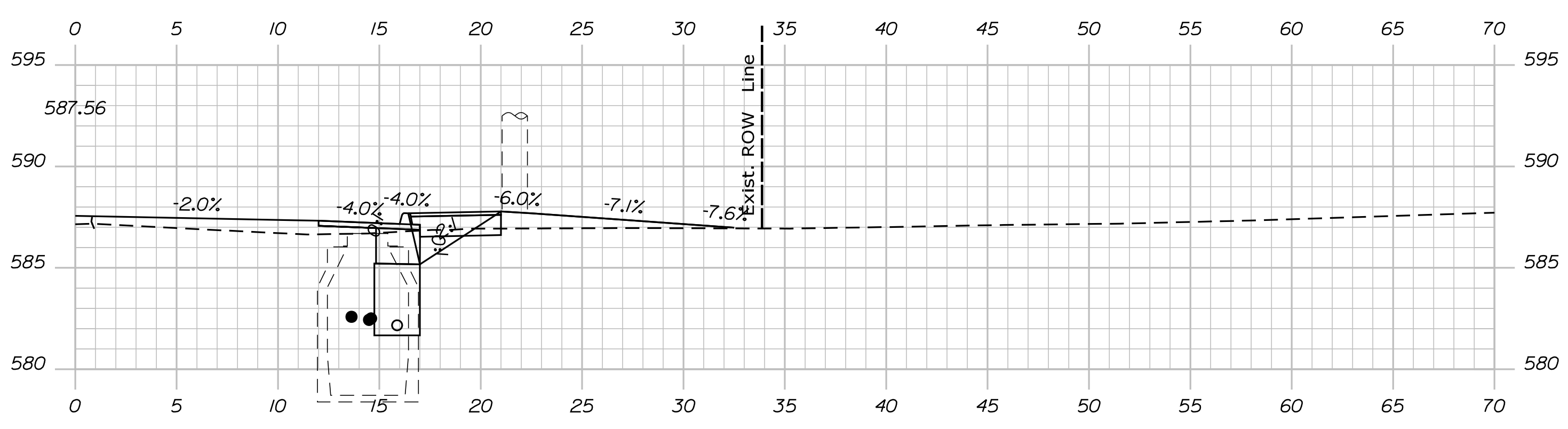

1046+41.00

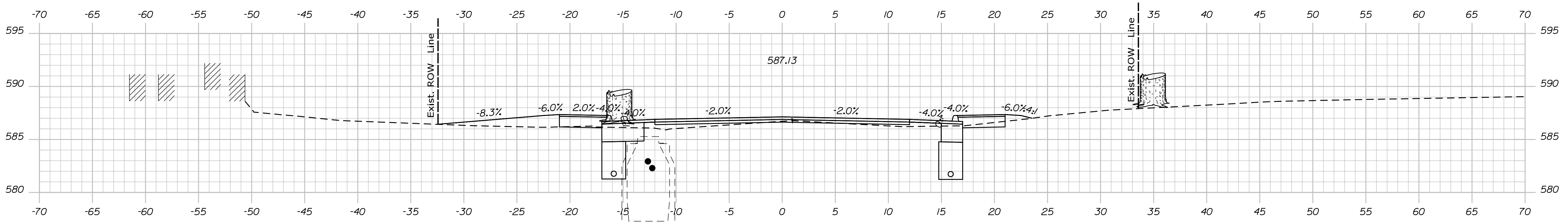

1046+00.00

STATE OF MAINE
 DEPARTMENT OF TRANSPORTATION
 STP-1824(500)
 WIN
 18245.00
 HIGHWAY PLANS

PROJ. MANAGER	DATE	BY	DATE
DESIGN/DETAILED			
CHECKED/REVIEWED			
DESIGN/DETAILED			
DESIGN/DETAILED			
REVISIONS 1			
REVISIONS 2			
REVISIONS 3			
REVISIONS 4			
FIELD CHANGES			

KINGFIELD
 ROUTE 16\27
 CROSS SECTIONS

SHEET NUMBER
Xse
 OF 175

Date: \$date\$

Username:

Division: HIGHWAY

Filename: ... \Bentley\ustrn\Xsect.dgn

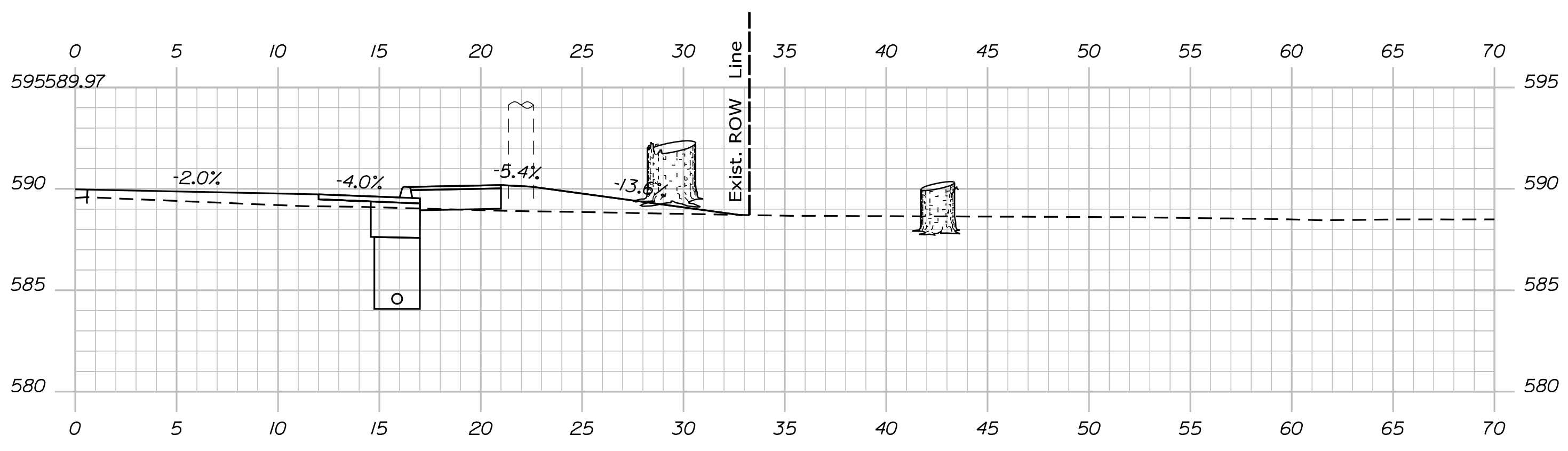

1048+00.00

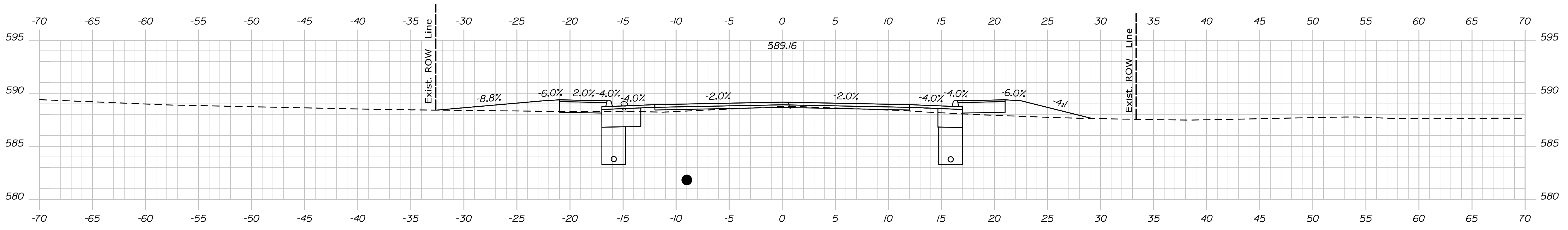

1047+50.00

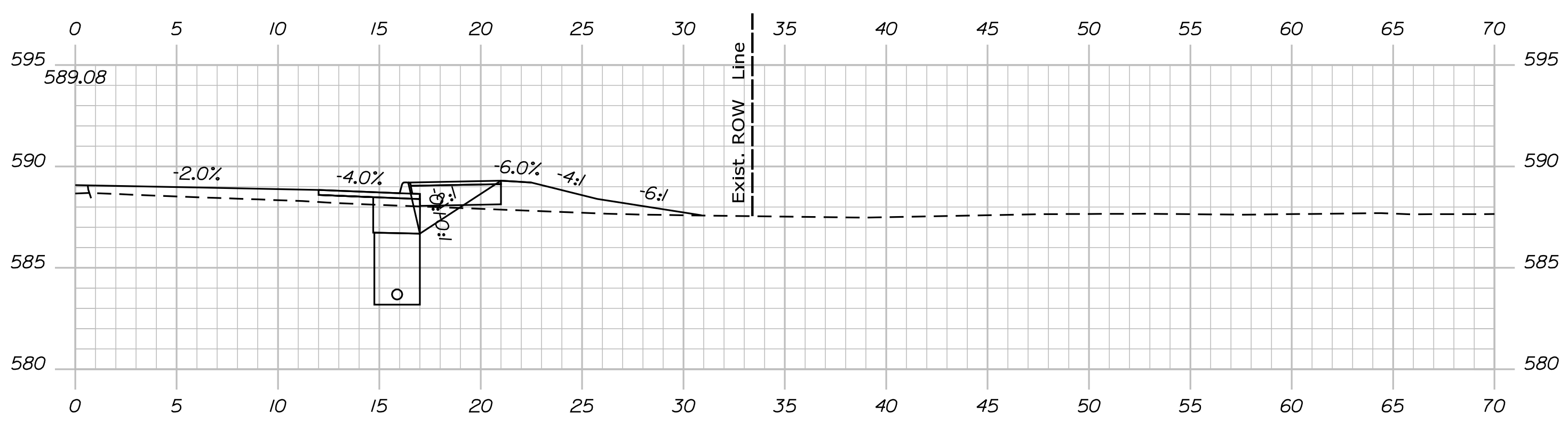

1047+45.00

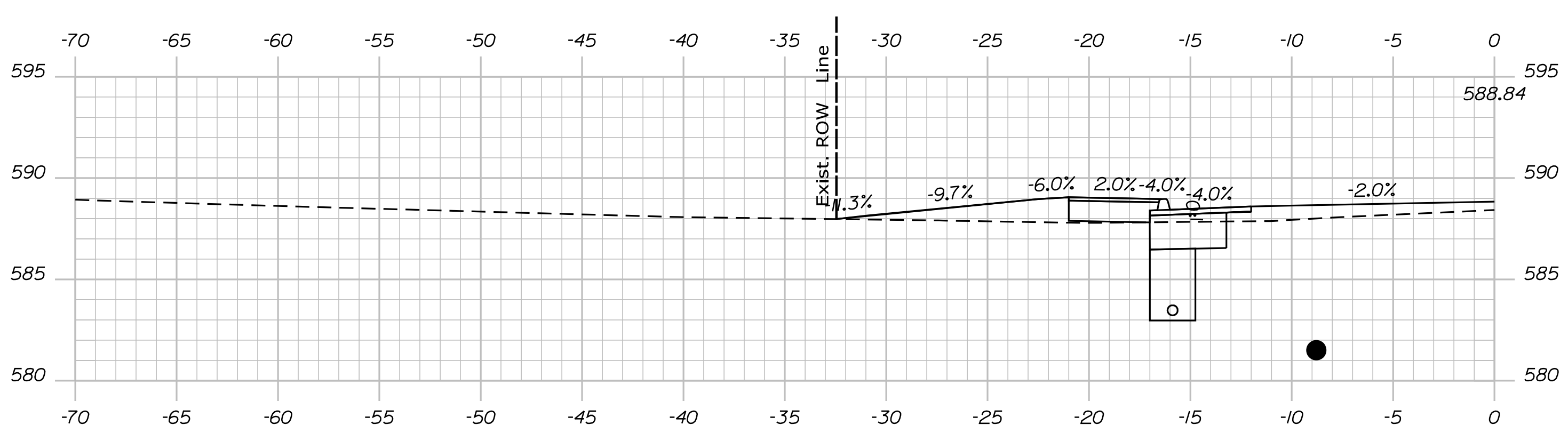

1047+29.00

STATE OF MAINE
DEPARTMENT OF TRANSPORTATION
STP-1824(500)
WIN
18245.00
HIERARCHIC PLANS

PROJ. MANAGER	DATE	BY	DATE
DESIGN/DETAILED			
CHECKED/REVIEWED			
DESIGN/DETAILED			
DESIGN/DETAILED			
REVISIONS 1			
REVISIONS 2			
REVISIONS 3			
REVISIONS 4			
FIELD CHANGES			

KINGFIELD
ROUTE 16\27
CROSS SECTIONS

SHEET NUMBER
Xse
OF 175

Date: \$date\$

Username:

Division: HIGHWAY

Filename: ... \Bentley\ustrn\Xsect.dgn

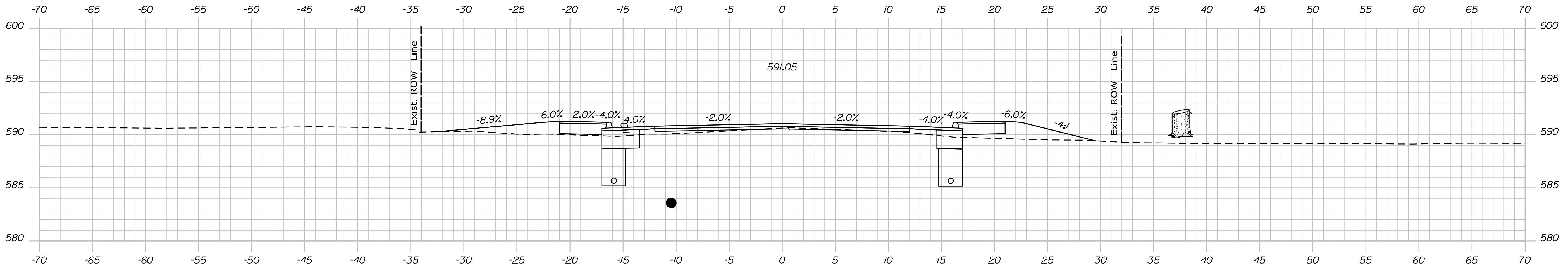

1049+00.00

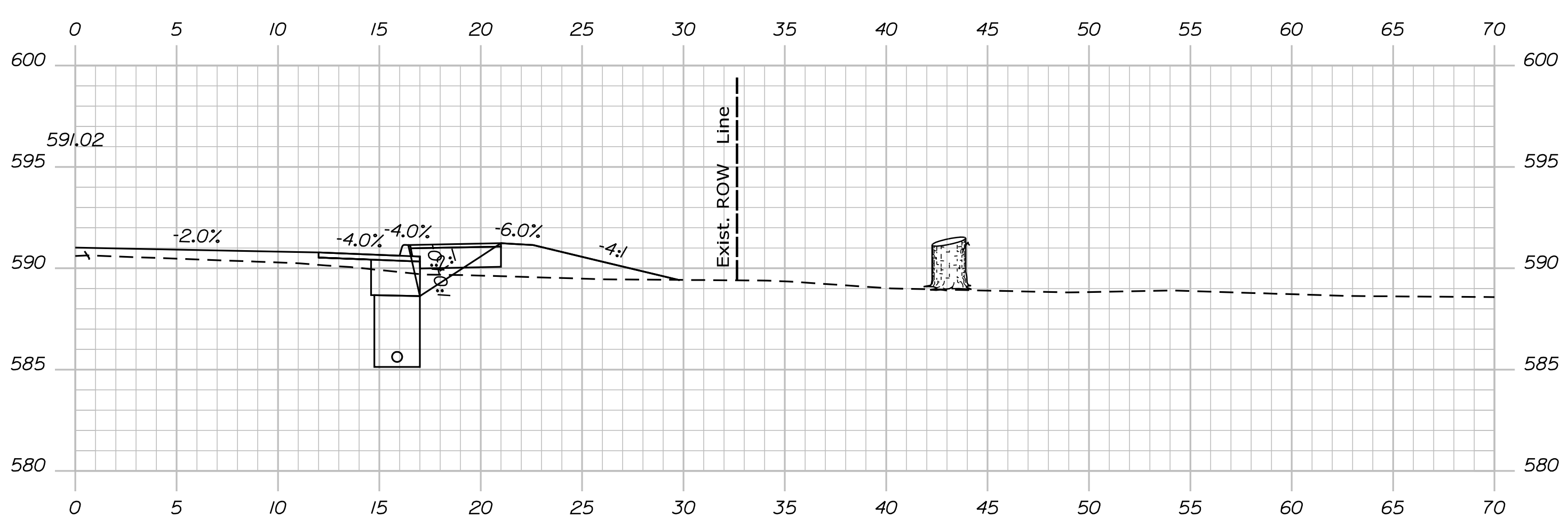

1048+97.00

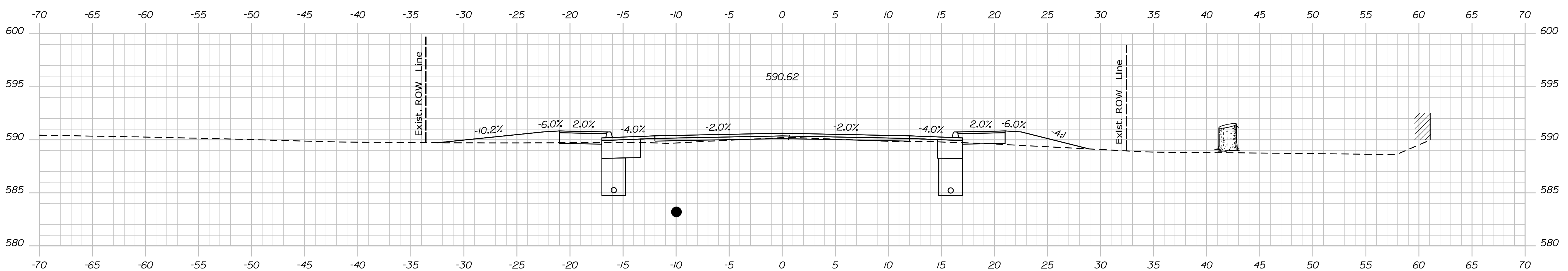

1048+50.00

STATE OF MAINE
DEPARTMENT OF TRANSPORTATION
STP-1824(500)
WIN
18245.00
HIERARCHIC PLANS

SIGNATURE	P.E. NUMBER	DATE
-----------	-------------	------

PROJ. MANAGER	BY	DATE
DESIGN DETAIL		
CHECKED/REVIEWED		
DESIGN DETAIL		
DESIGN DETAIL		
REVISIONS 1		
REVISIONS 2		
REVISIONS 3		
REVISIONS 4		
FIELD CHANGES		

KINGFIELD
ROUTE 16\27
CROSS SECTIONS

SHEET NUMBER
Xse
OF 175

Date: \$date\$

Username:

Division: HIGHWAY

Filename: ... \Bentley\ustrn\Xsect.dgn

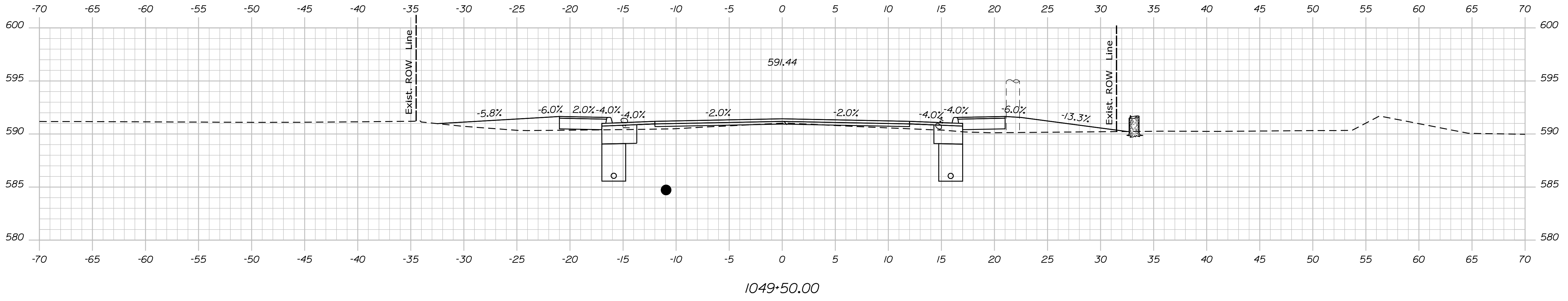
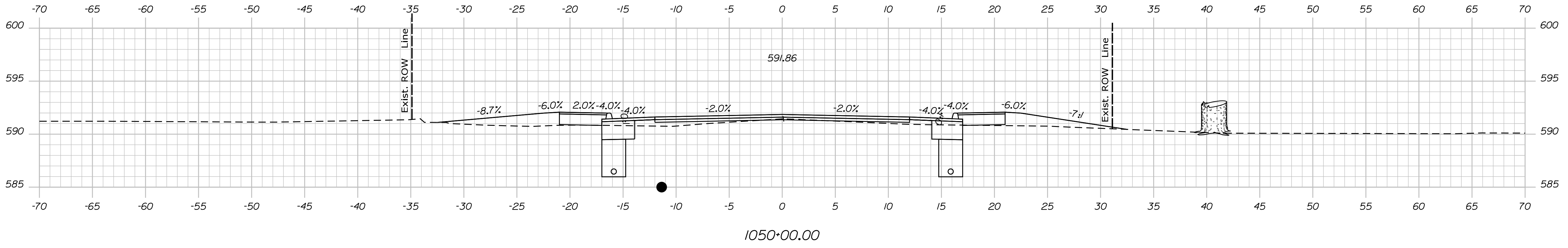
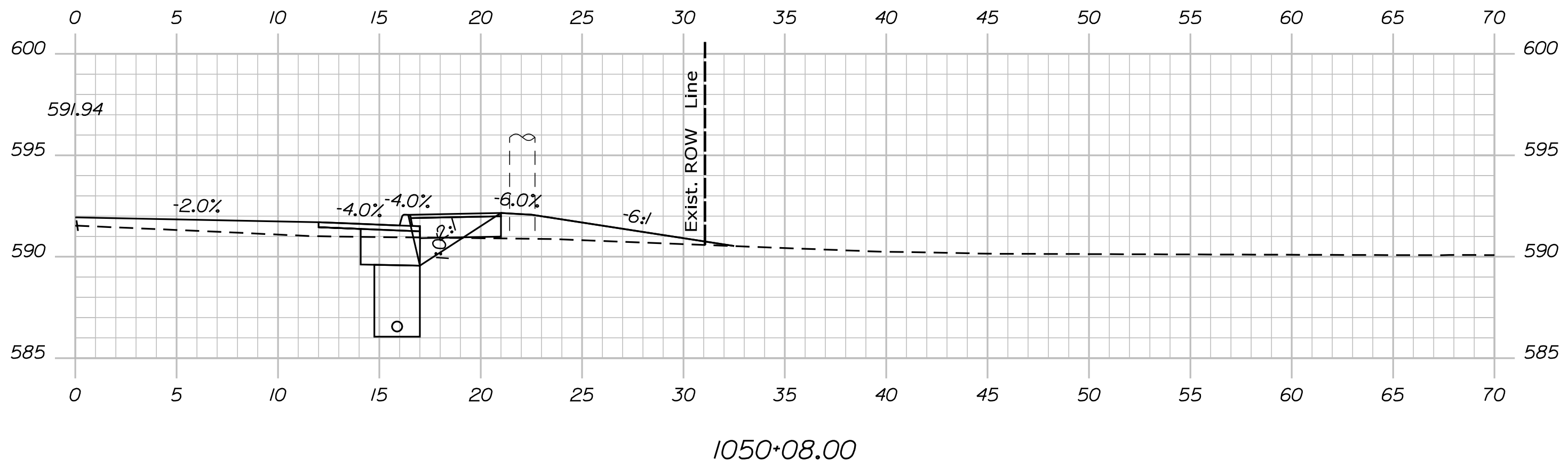
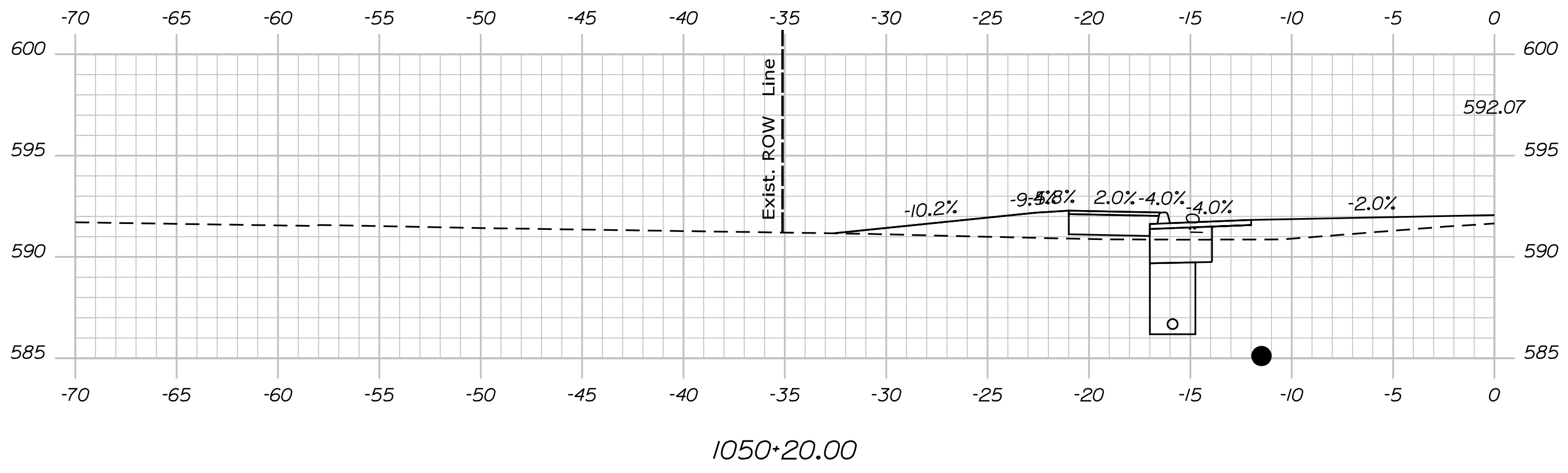

STATE OF MAINE
DEPARTMENT OF TRANSPORTATION
STP-1824(500)
WIN
18245.00
HIERARCHIC PLANS

PROJ. MANAGER	DATE	BY	DATE
DESIGN DETAILED			
CHECKED/REVISED			
DESIGN DETAILED			
DESIGN DETAILED			
REVISIONS 1			
REVISIONS 2			
REVISIONS 3			
REVISIONS 4			
FIELD CHANGES			

KINGFIELD
ROUTE 16\27
CROSS SECTIONS

SHEET NUMBER
Xse
OF 175

Date: \$date\$

Username:

Division: HIGHWAY

Filename: ... \Bentley\ustrn\Xsect.dgn

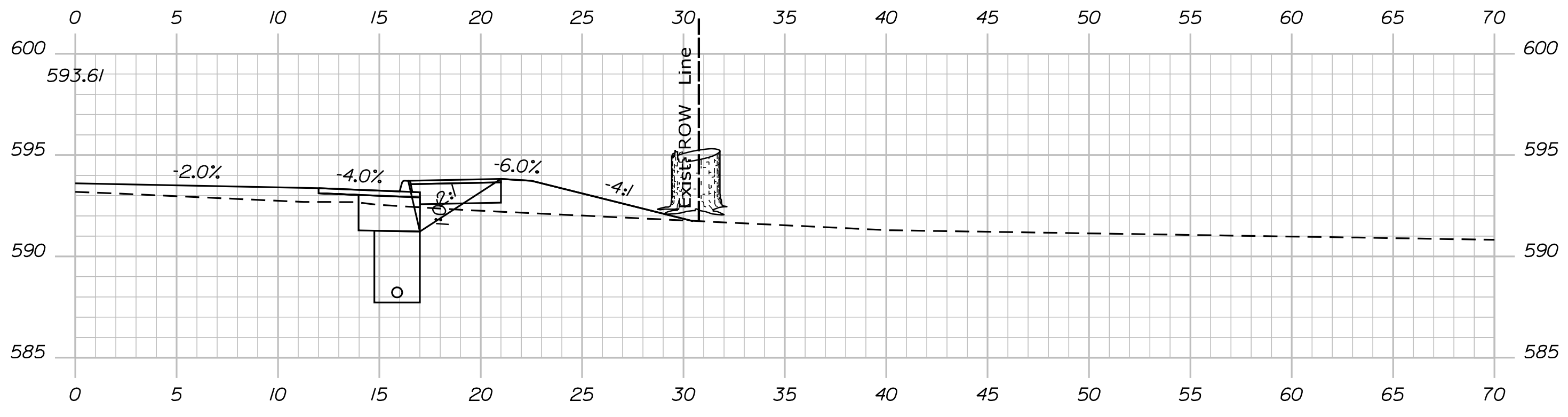

1051+35.00

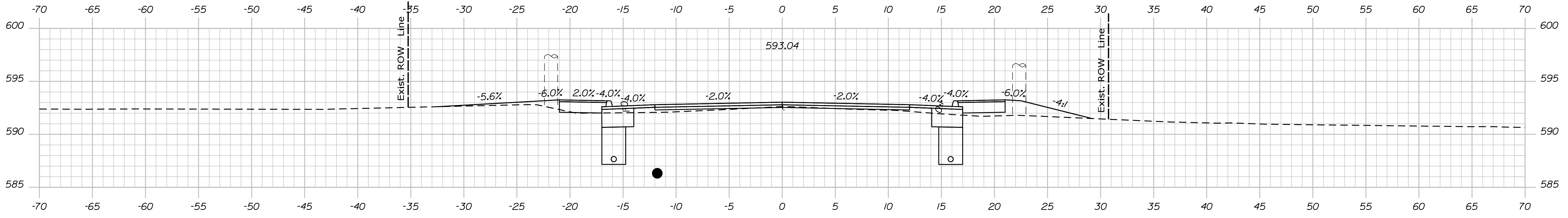

1051+00.00

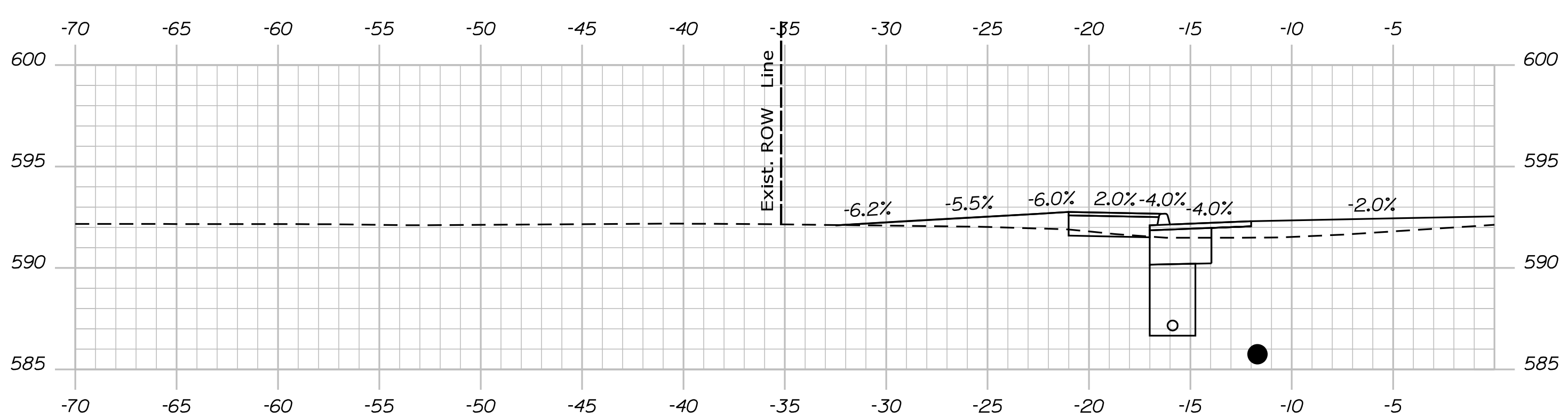

1050+64.00

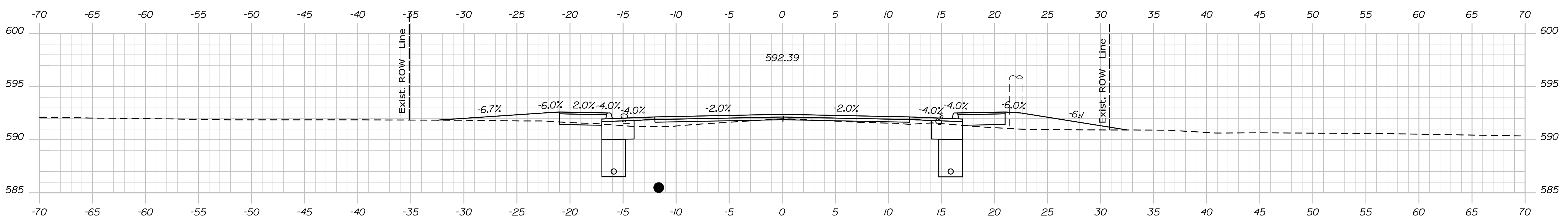

1050+50.00

STATE OF MAINE
DEPARTMENT OF TRANSPORTATION
STP-1824(500)
WIN
18245.00
HIERARCHIC PLANS

PROJ. MANAGER \$PROJMANAGER\$
DESIGN DETAILED
CHECKED/REVIEWED
DESIGN DETAILED
DESIGN DETAILED
REVISIONS 1
REVISIONS 2
REVISIONS 3
REVISIONS 4
FIELD CHANGES

BY	DATE	SIGNATURE	P.E. NUMBER	DATE

KINGFIELD
ROUTE 16\27
CROSS SECTIONS

SHEET NUMBER
Xse
OF 175

Date: \$date\$

Username:

Division: HIGHWAY

Filename: ... \Bentley\ustrn\Xsect.dgn

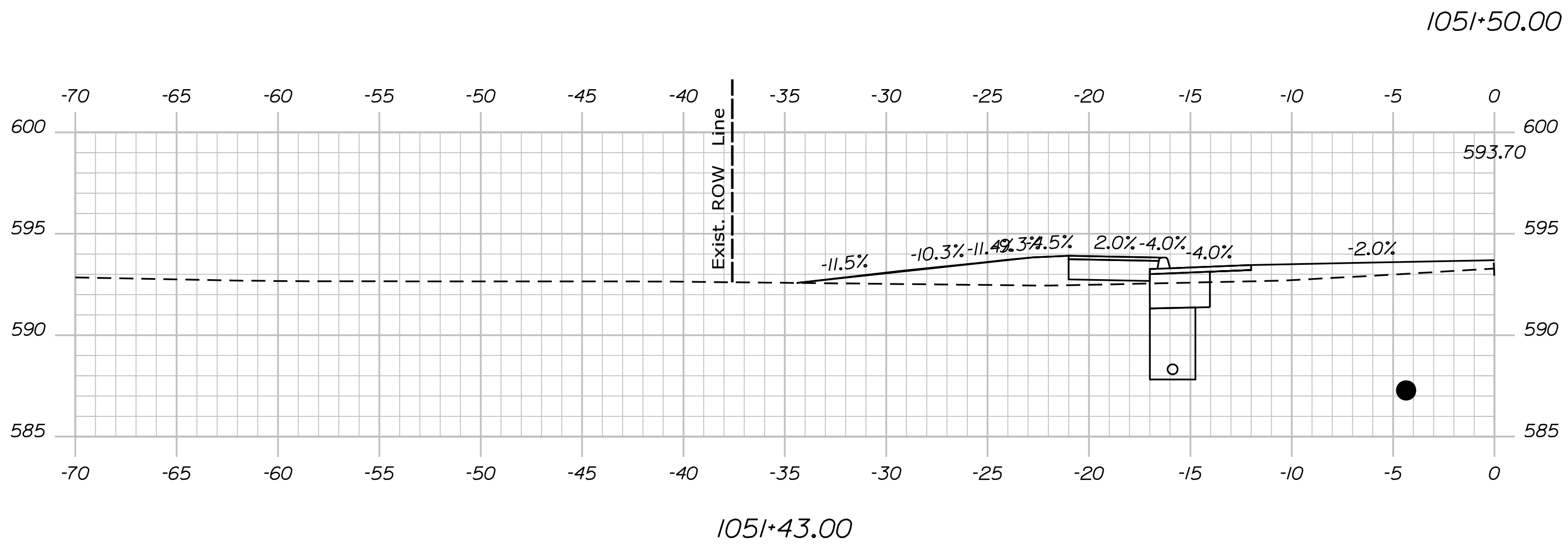
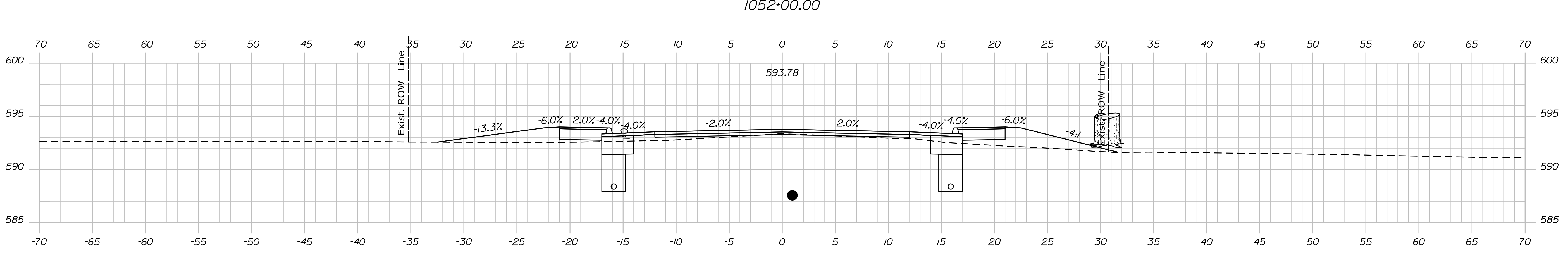
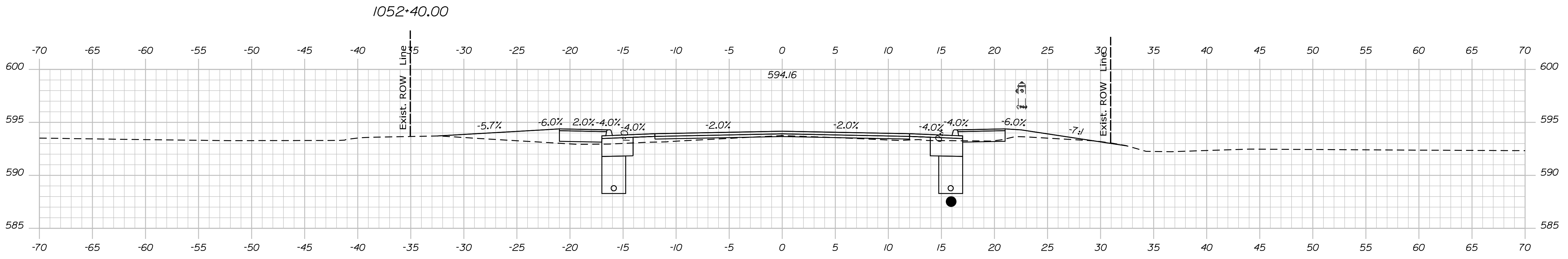
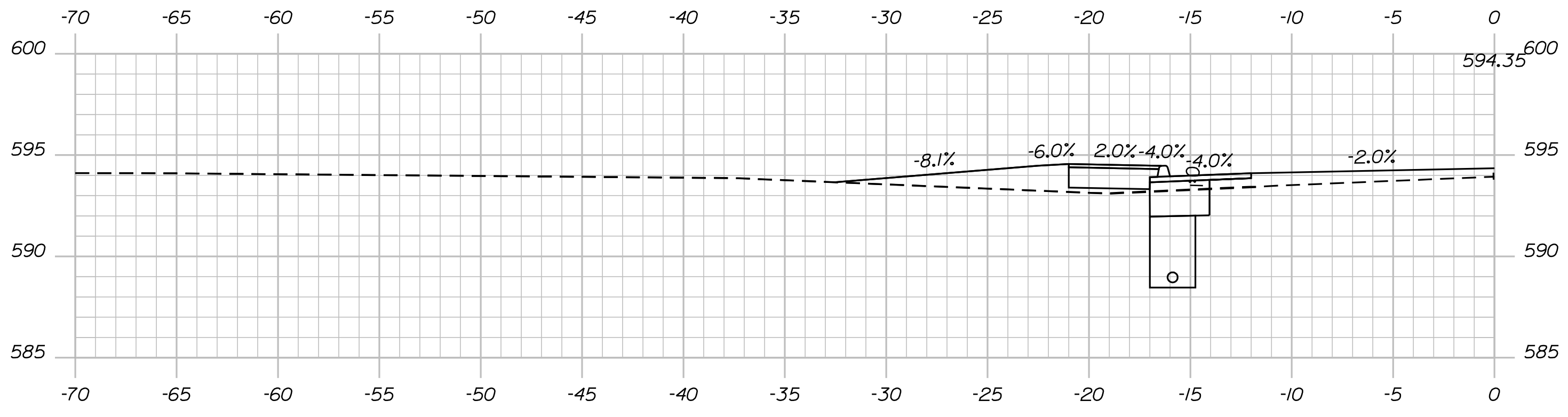

STATE OF MAINE
DEPARTMENT OF TRANSPORTATION
STP-1824(500)
WIN
18245.00
HIERARCHIC PLANS

SIGNATURE
P.E. NUMBER
DATE

PROJ. MANAGER	DATE
DESIGN DETAIL	
CHECKED/REVIEWED	
DESIGN DETAIL	
DESIGN DETAIL	
REVISIONS 1	
REVISIONS 2	
REVISIONS 3	
REVISIONS 4	
FIELD CHANGES	

KINGFIELD
ROUTE 16\27
CROSS SECTIONS

SHEET NUMBER
Xse
OF 175

Date: \$date\$

Username:

Division: HIGHWAY

Filename: ... \Bentley\ustrn\Xsect.dgn

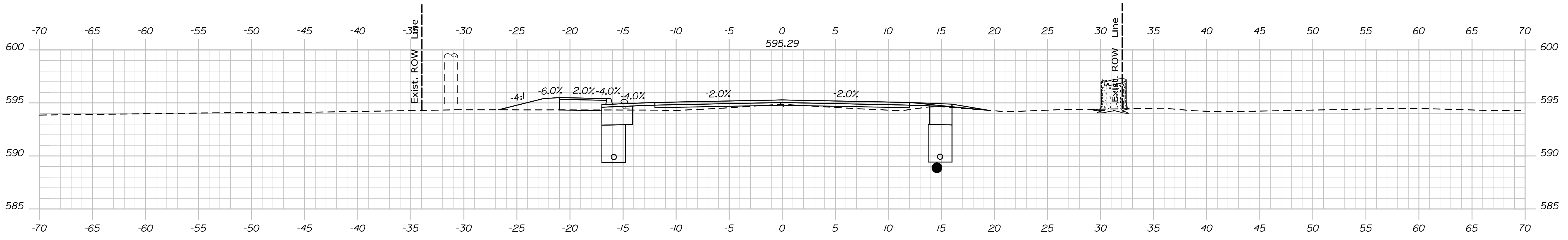

1053+50.00

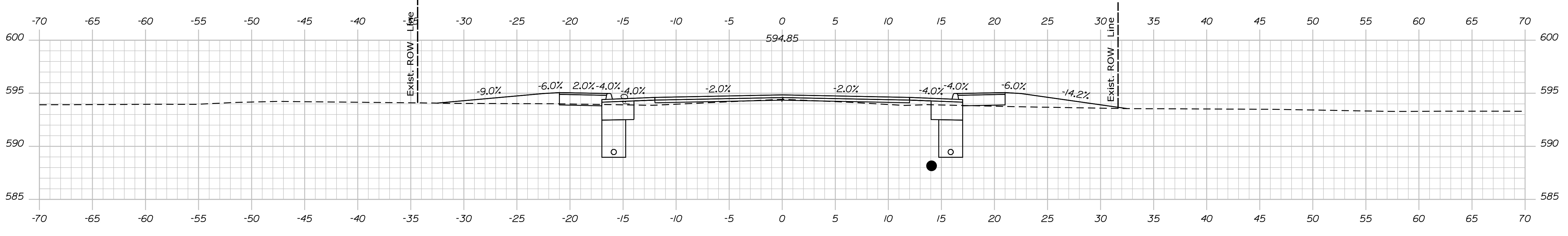

1053+00.00

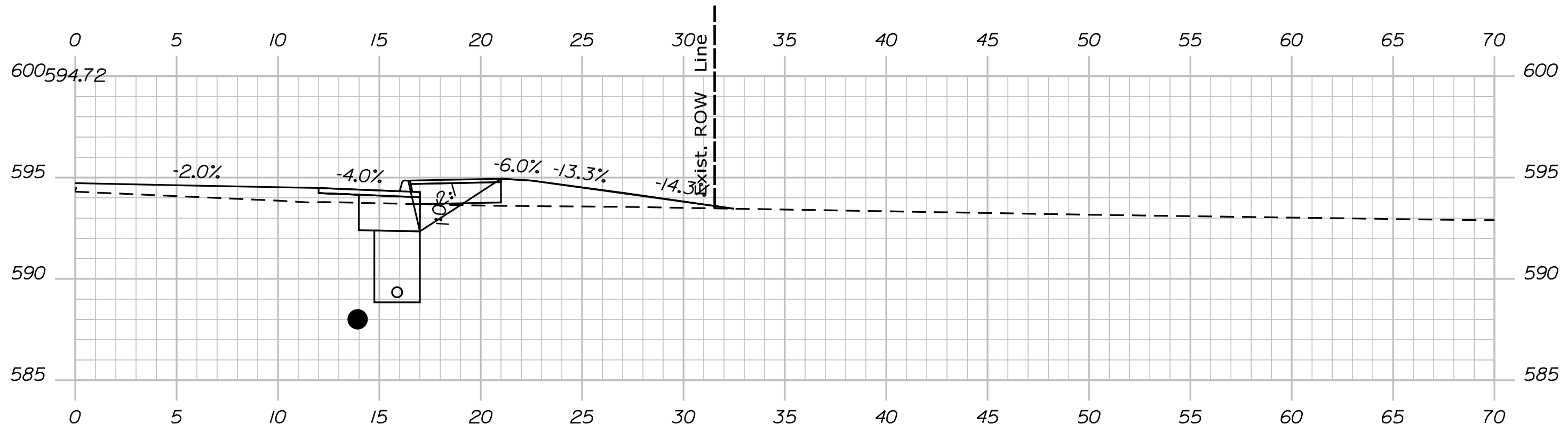

1052+86.00

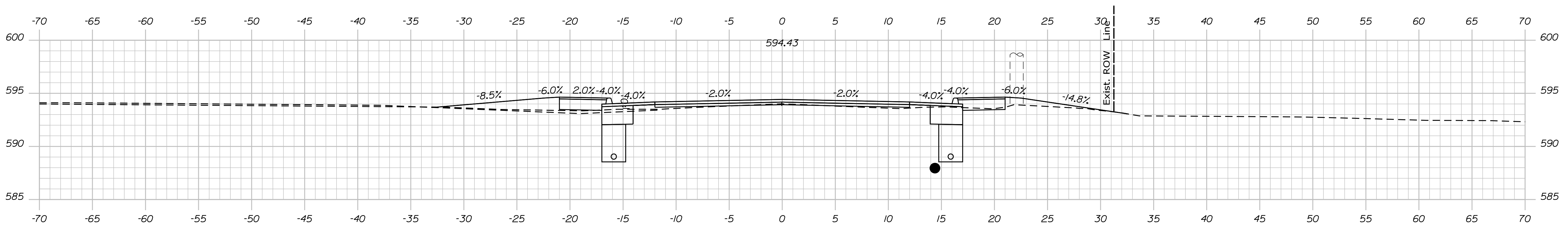

1052+50.00

STATE OF MAINE
 DEPARTMENT OF TRANSPORTATION
 STP-1824(500)
 WIN
 18245.00
 HIGHWAY PLANS

PROJ. MANAGER	DATE
DESIGN DETAIL	SIGNATURE
CHECKED/REVISED	P.E. NUMBER
DESIGN DETAIL	DATE
DESIGN DETAIL	
REVISIONS 1	
REVISIONS 2	
REVISIONS 3	
REVISIONS 4	
FIELD CHANGES	

KINGFIELD
 ROUTE 16\27
 CROSS SECTIONS

SHEET NUMBER
Xse
 OF 175

Date: \$date\$

Username:

Division: HIGHWAY

Filename: ... \Bentley\ustrn\Xsect.dgn

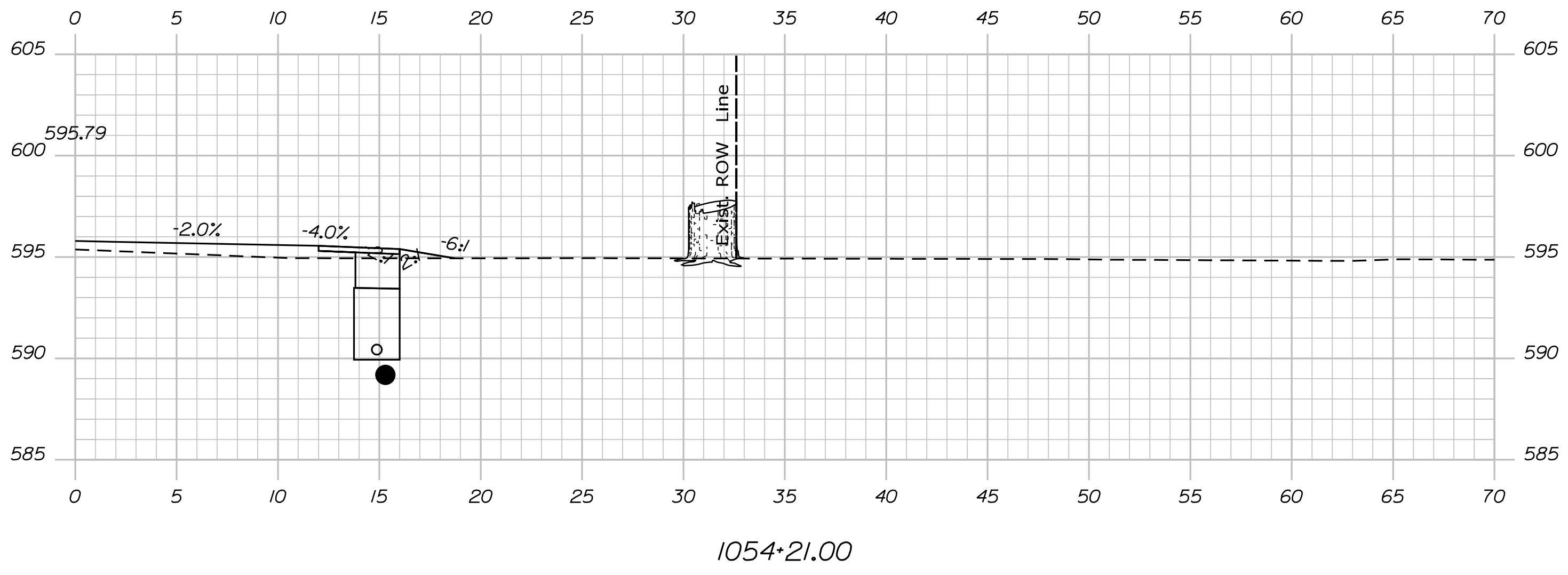

1054+21.00

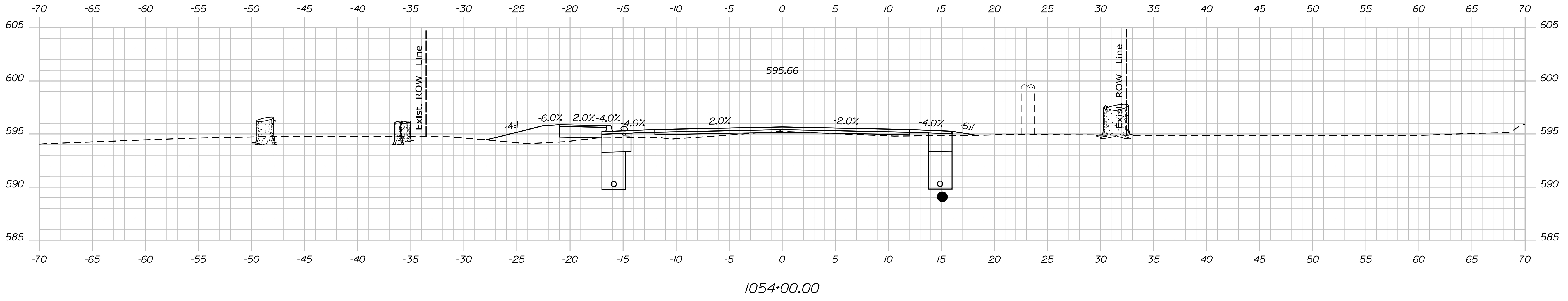

1054+00.00

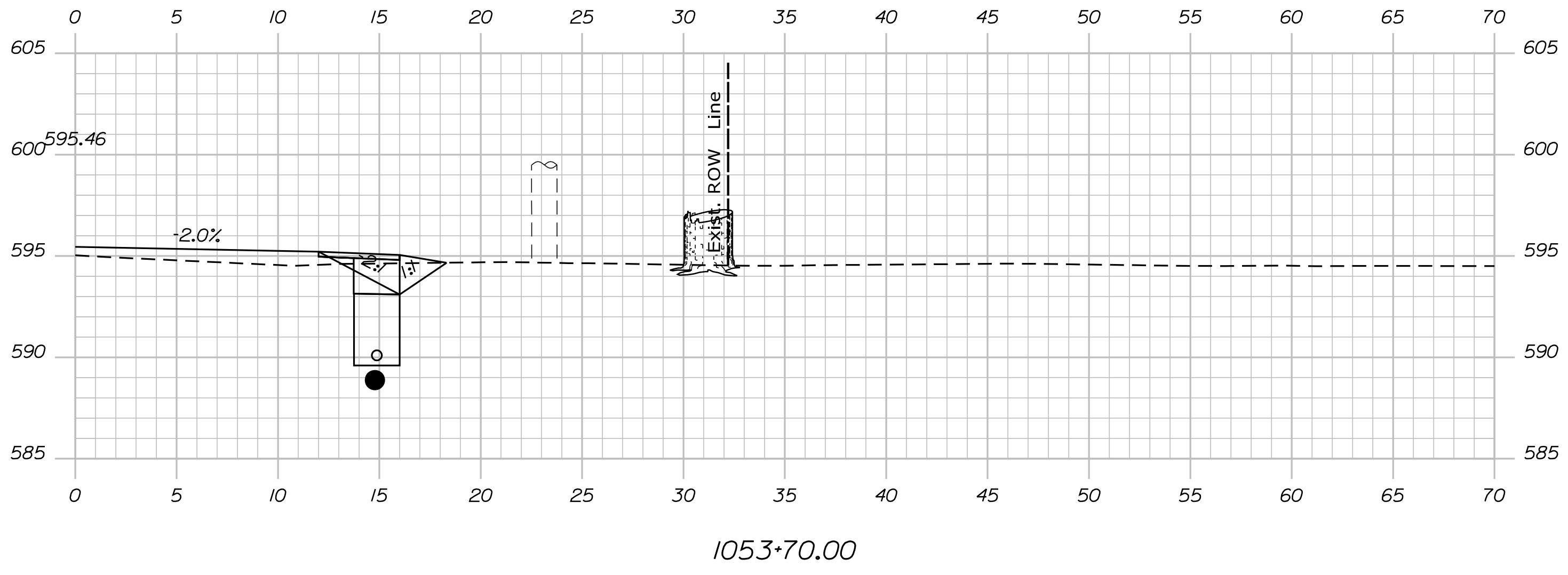

1053+70.00

STATE OF MAINE
DEPARTMENT OF TRANSPORTATION
STP-1824(500)
WIN
18245.00
HIERARCHIC PLANS

SIGNATURE
P.E. NUMBER
DATE

PROJ. MANAGER	DATE
DESIGN DETAILED	
CHECKED/REVIEWED	
DESIGN DETAILED	
DESIGN DETAILED	
REVISIONS 1	
REVISIONS 2	
REVISIONS 3	
REVISIONS 4	
FIELD CHANGES	

KINGFIELD
ROUTE 16\27
CROSS SECTIONS

SHEET NUMBER
Xse
OF 175

Date: \$date\$

Username:

Division: HIGHWAY

Filename: ... \Bentley\ustrn\Xsect.dgn

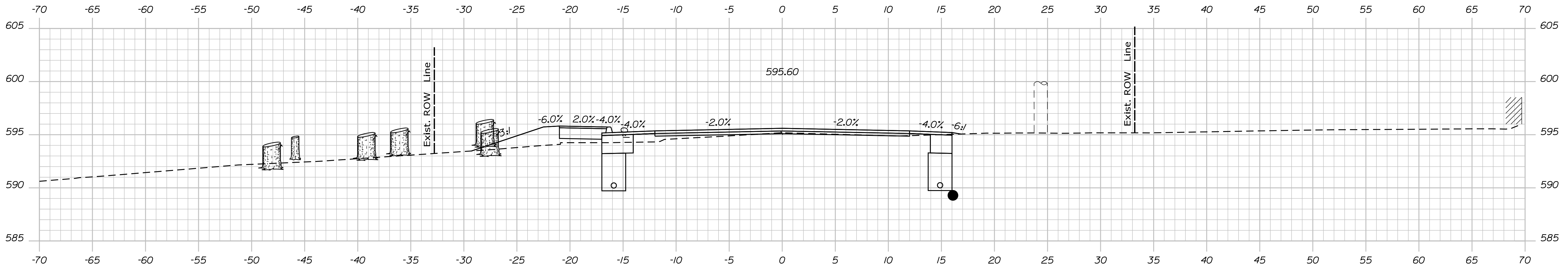

1055+00.00

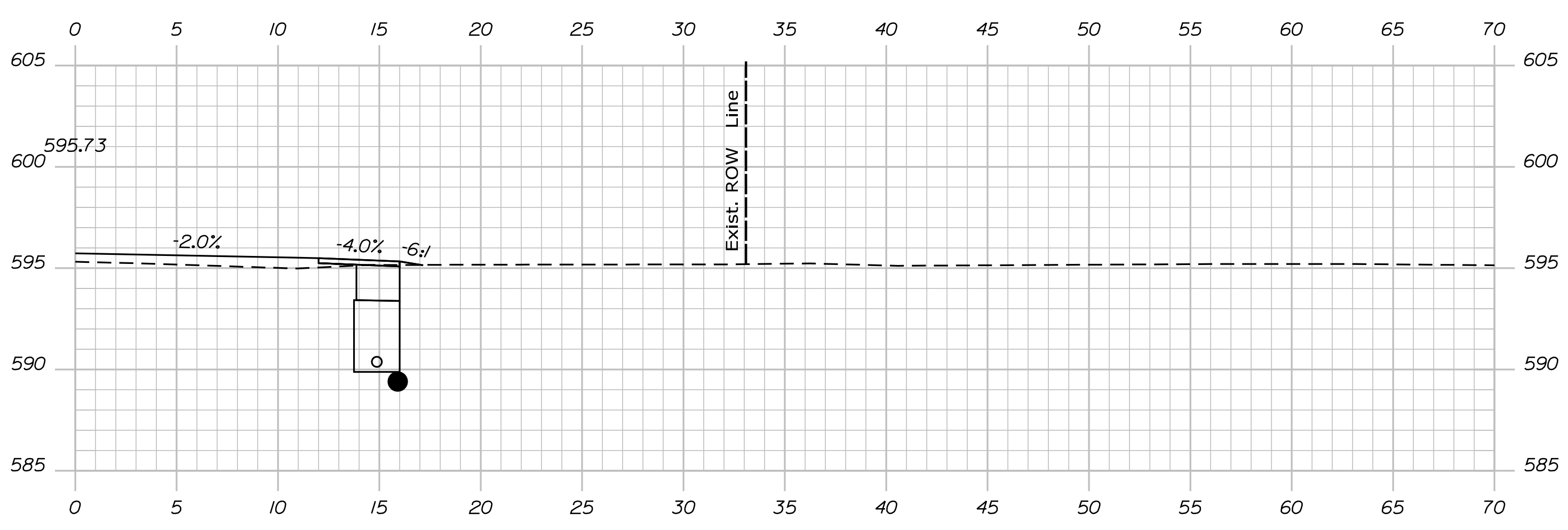

1054+81.00

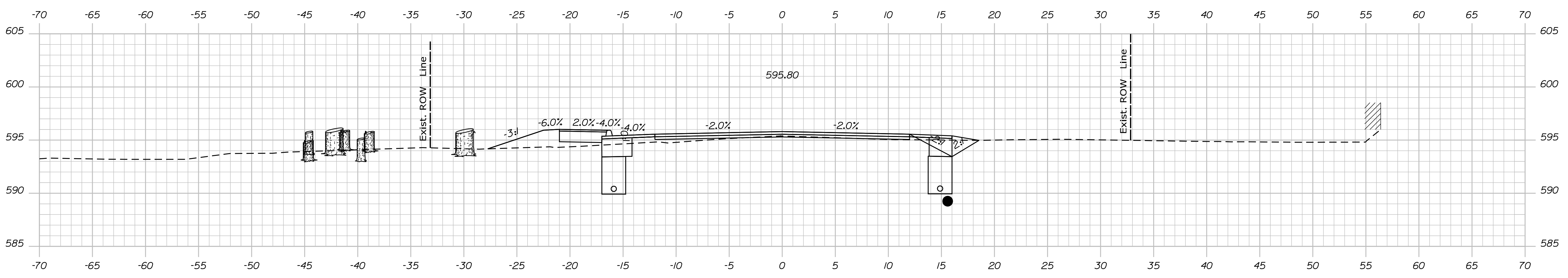

1054+50.00

STATE OF MAINE
DEPARTMENT OF TRANSPORTATION
STP-1824(500)
WIN
18245.00
HIERARCHIC PLANS

SIGNATURE
P.E. NUMBER
DATE

PROJ. MANAGER	DATE
DESIGN DETAIL	
CHECKED/REVISED	
DESIGN DETAIL	
DESIGN DETAIL	
REVISIONS 1	
REVISIONS 2	
REVISIONS 3	
REVISIONS 4	
FIELD CHANGES	

KINGFIELD
ROUTE 16\27
CROSS SECTIONS

SHEET NUMBER
Xse
OF 175

Date: \$date\$

Username:

Division: HIGHWAY

Filename: ... \Bentley\ustrn\Xsect.dgn

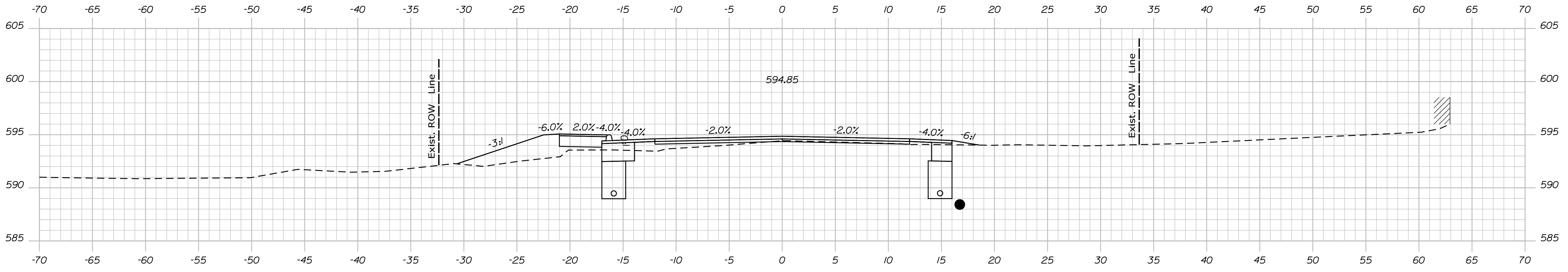

1056+00.00

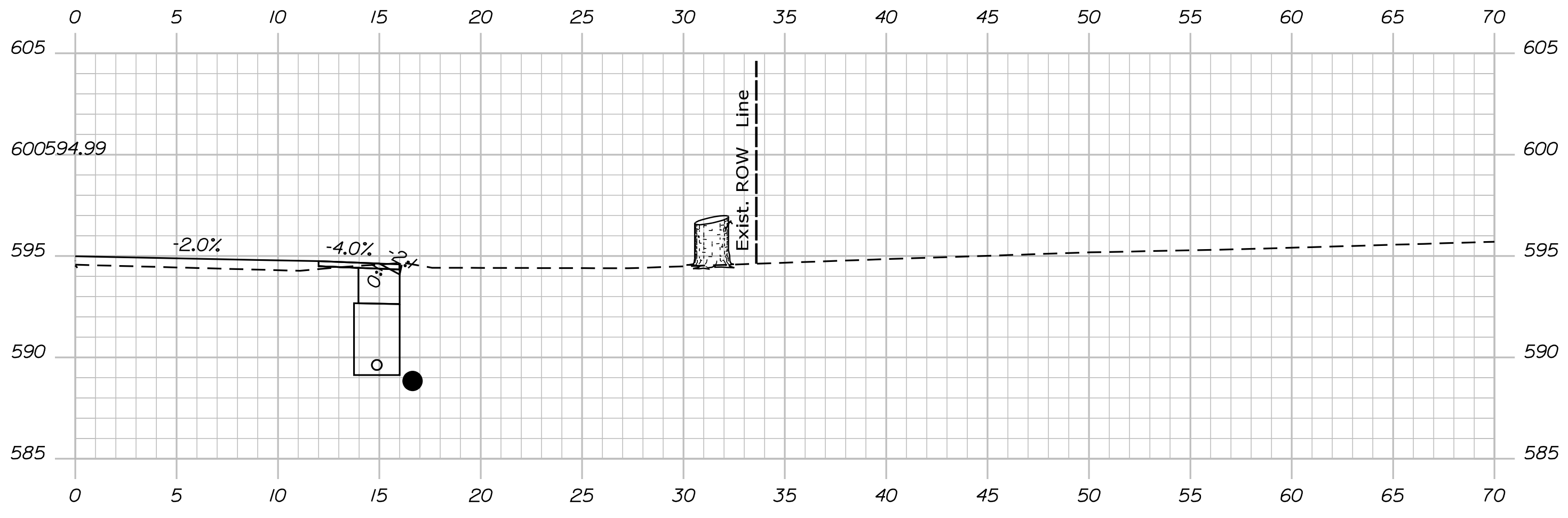

1055+79.00

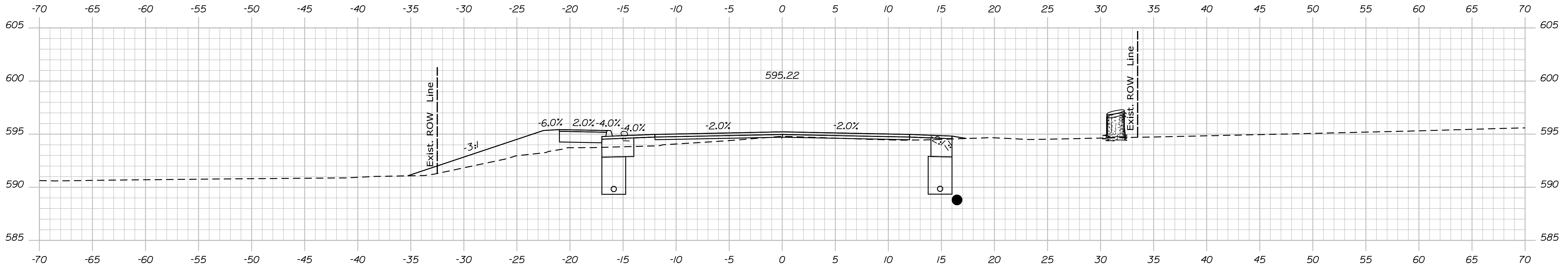

1055+50.00

STATE OF MAINE
DEPARTMENT OF TRANSPORTATION
STP-1824(500)
WIN
18245.00
HIERARCHIC PLANS

SIGNATURE
P.E. NUMBER
DATE

PROJ. MANAGER	DATE
DESIGN/DETAILED	
CHECKED/REVIEWED	
DESIGN/DETAILED	
DESIGN/DETAILED	
REVISIONS 1	
REVISIONS 2	
REVISIONS 3	
REVISIONS 4	
FIELD CHANGES	

KINGFIELD
ROUTE 16\27
CROSS SECTIONS

SHEET NUMBER
Xse
OF 175

Date: \$date\$

Username:

Division: HIGHWAY

Filename: ... \Bentley\ustrn\Xsect.dgn

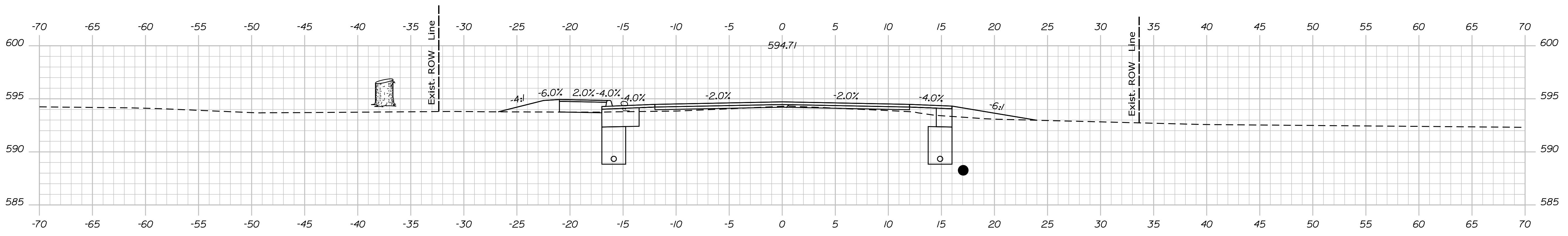

1057+50.00

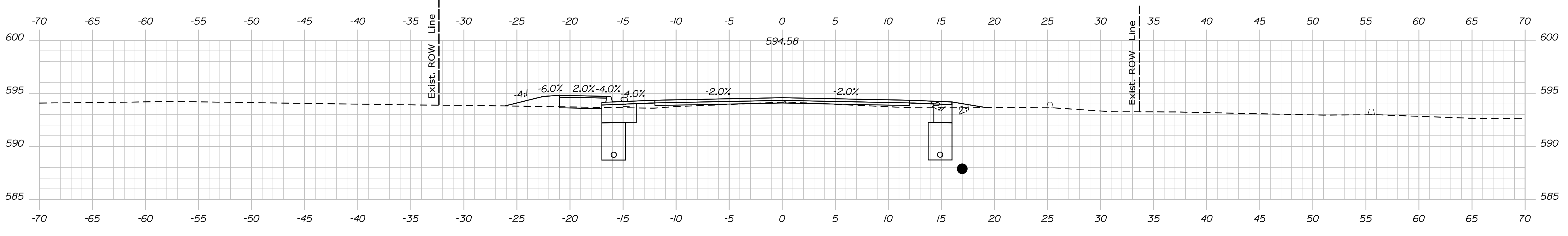

1057+00.00

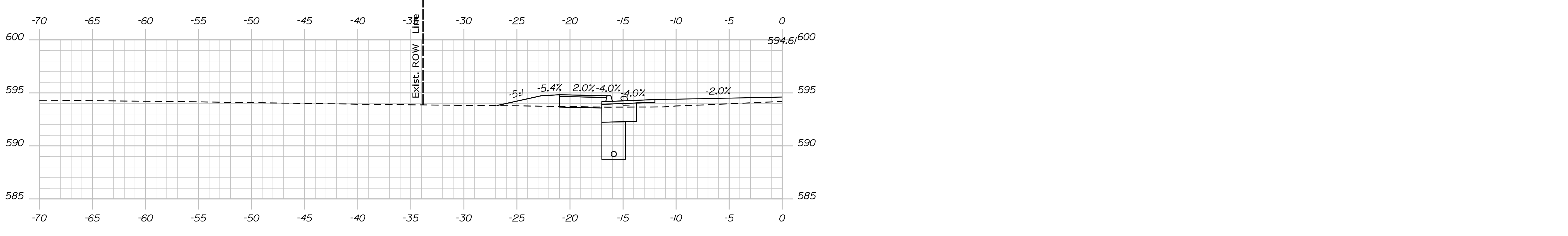

1056+89.00

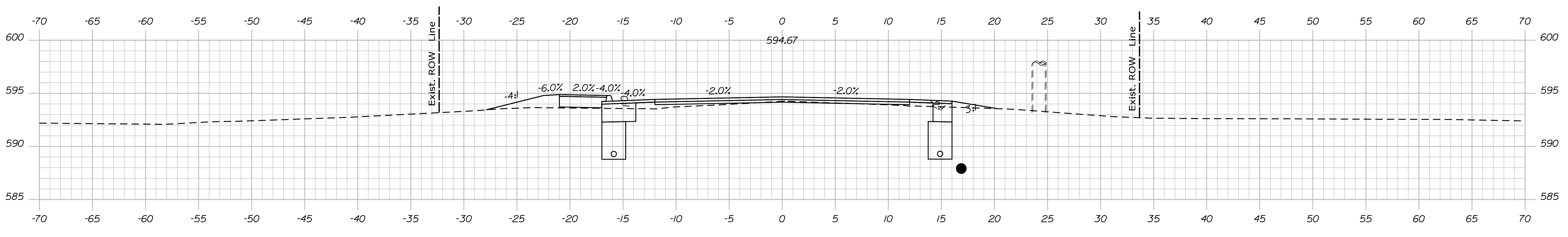

1056+50.00

STATE OF MAINE
DEPARTMENT OF TRANSPORTATION
STP-1824(500)
WIN
18245.00
HIERARCHIC PLANS

PROJ. MANAGER	DATE	BY	DATE
DESIGN DETAIL			
CHECKED/REVIEWED			
DESIGN DETAIL			
DESIGN DETAIL			
REVISIONS 1			
REVISIONS 2			
REVISIONS 3			
REVISIONS 4			
FIELD CHANGES			

KINGFIELD
ROUTE 16\27
CROSS SECTIONS

SHEET NUMBER
Xse
OF 175

Date: \$date\$

Username:

Division: HIGHWAY

Filename: ... \Bentley\ustrn\Xsect.dgn

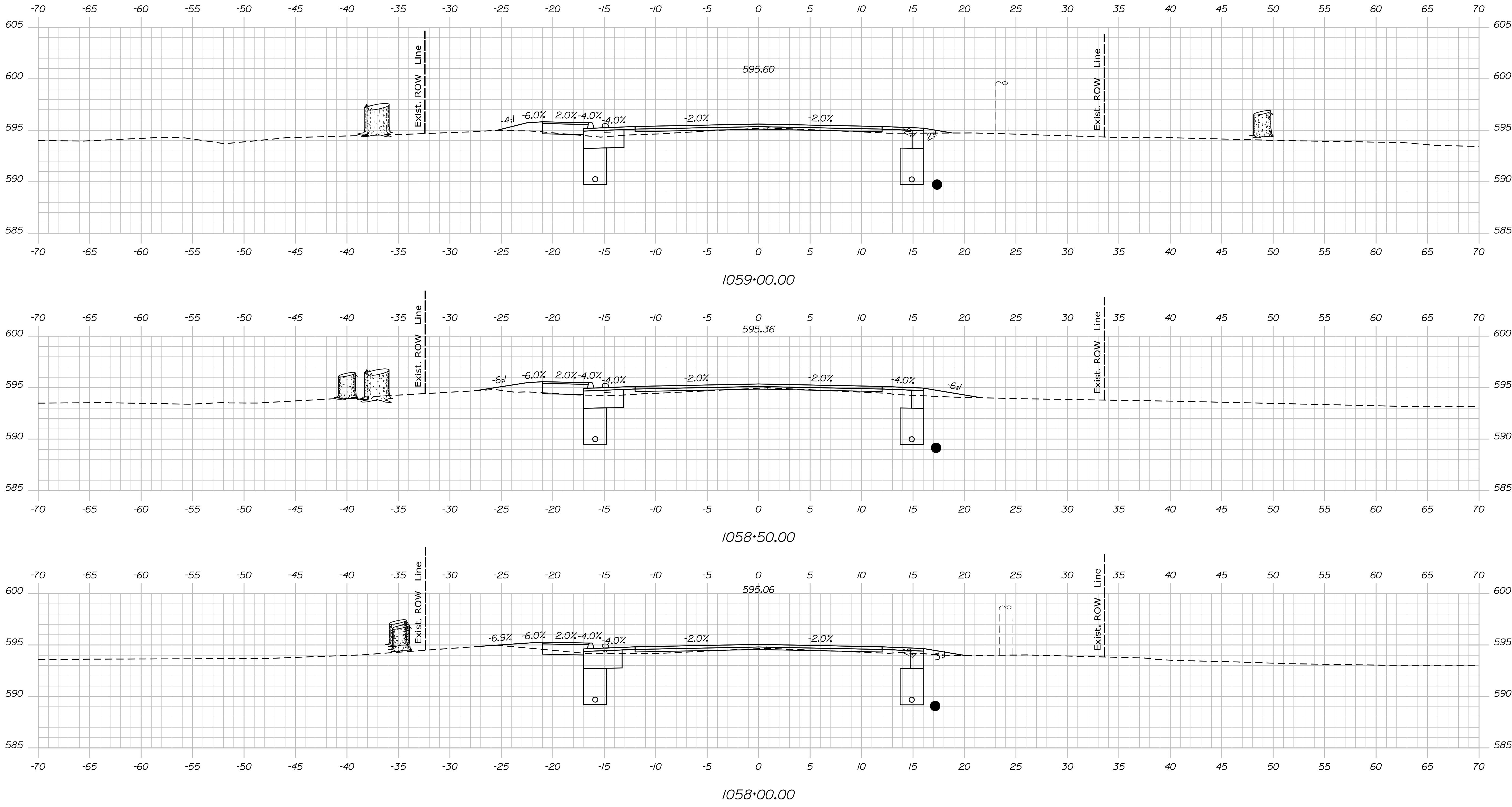

STATE OF MAINE
 DEPARTMENT OF TRANSPORTATION
 STP-1824(500)
 WIN
 18245.00
 HIGHWAY PLANS

PROJ. MANAGER	DATE
CHECKED/REVIEWED	SIGNATURE
DESIGN DETAILER	P.E. NUMBER
DESIGN DETAILER	DATE
REVISIONS 1	
REVISIONS 2	
REVISIONS 3	
REVISIONS 4	
FIELD CHANGES	

PROJ. MANAGER \$PROJMANAGER\$

KINGFIELD
 ROUTE 16\27
 CROSS SECTIONS

SHEET NUMBER
Xse
 OF 175

Date: \$date\$

Username:

Division: HIGHWAY

Filename: ... \Bentley\ustr\Xsect.dgn

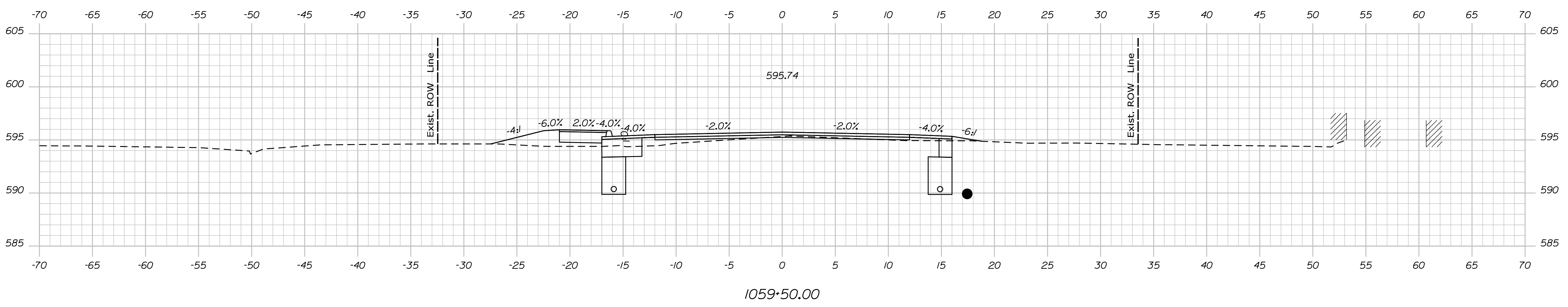
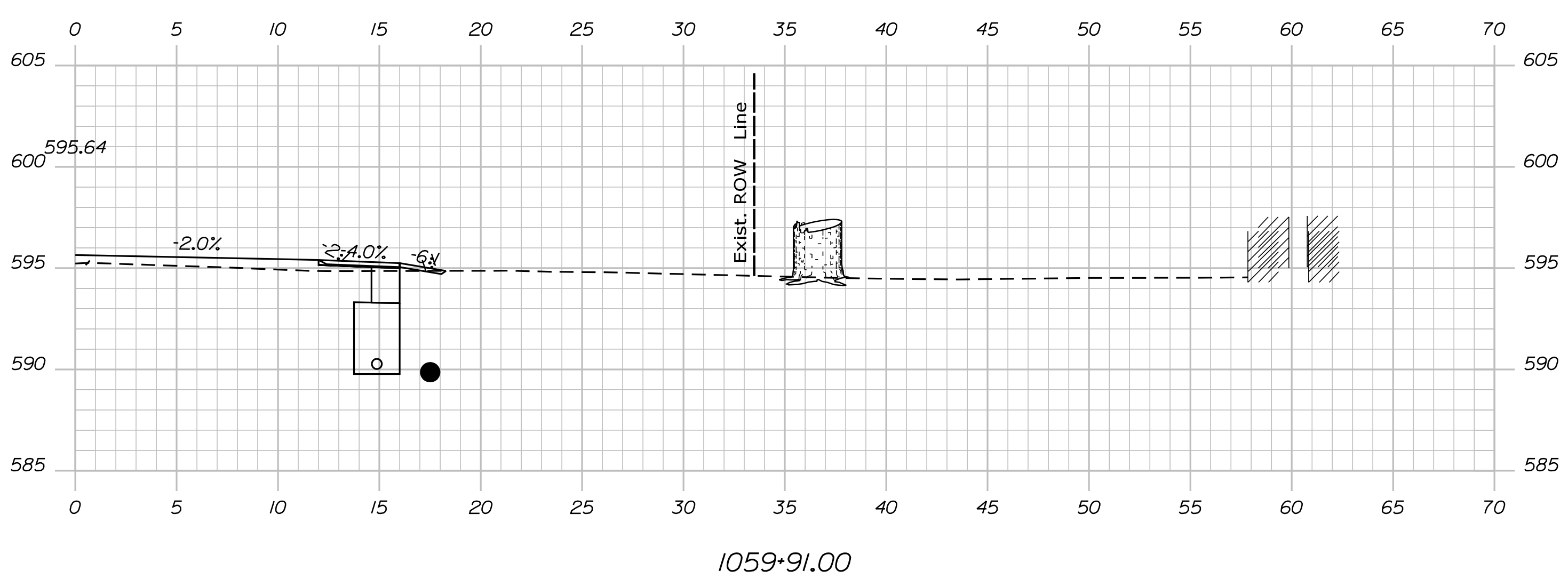
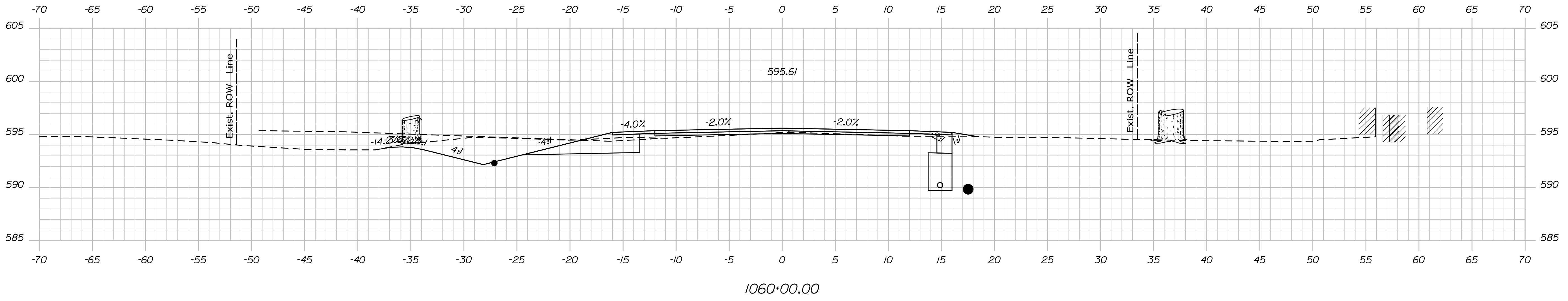

STATE OF MAINE
DEPARTMENT OF TRANSPORTATION
STP-1824(500)
WIN
18245.00
HIERARCHIC PLANS

SIGNATURE
P.E. NUMBER
DATE

PROJ. MANAGER	BY	DATE
DESIGN DETAIL		
CHECKED/REVIEWED		
DESIGN DETAIL		
DESIGN DETAIL		
REVISIONS 1		
REVISIONS 2		
REVISIONS 3		
REVISIONS 4		
FIELD CHANGES		

KINGFIELD
ROUTE 16\27
CROSS SECTIONS

SHEET NUMBER
Xse
OF 175

Date: \$date\$

Username:

Division: HIGHWAY

Filename: ... \Bentley\ustrn\Xsect.dgn

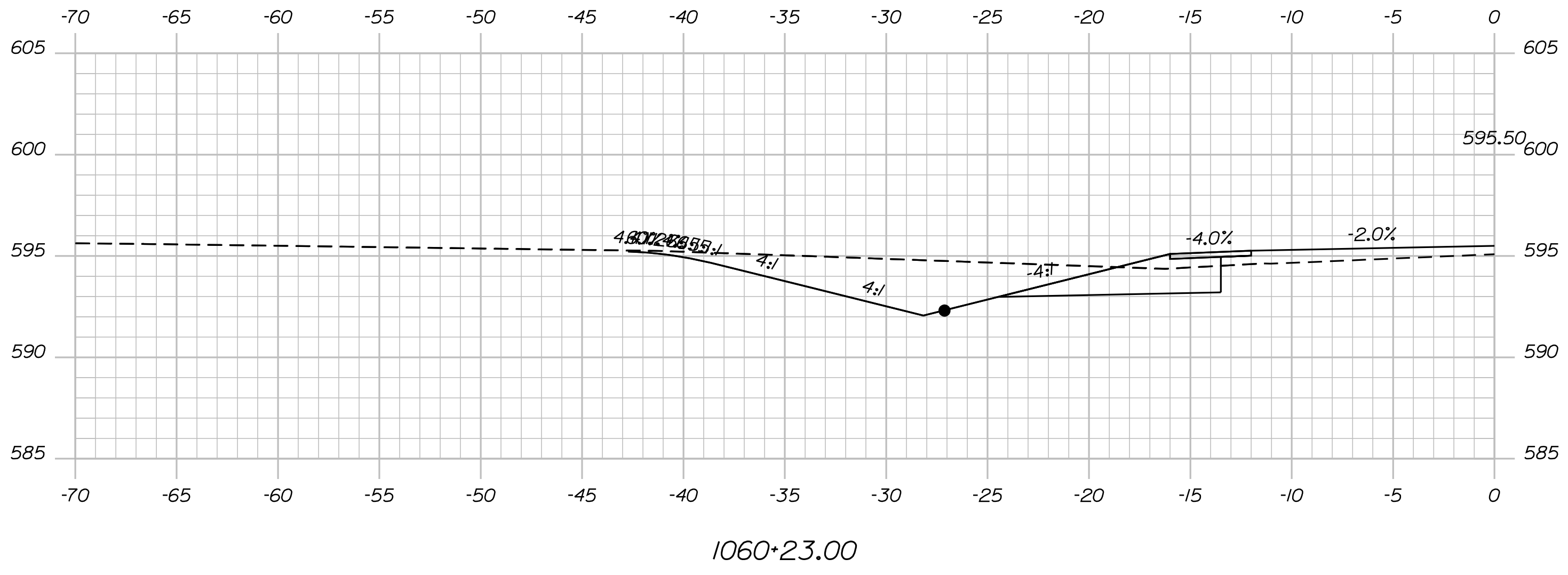
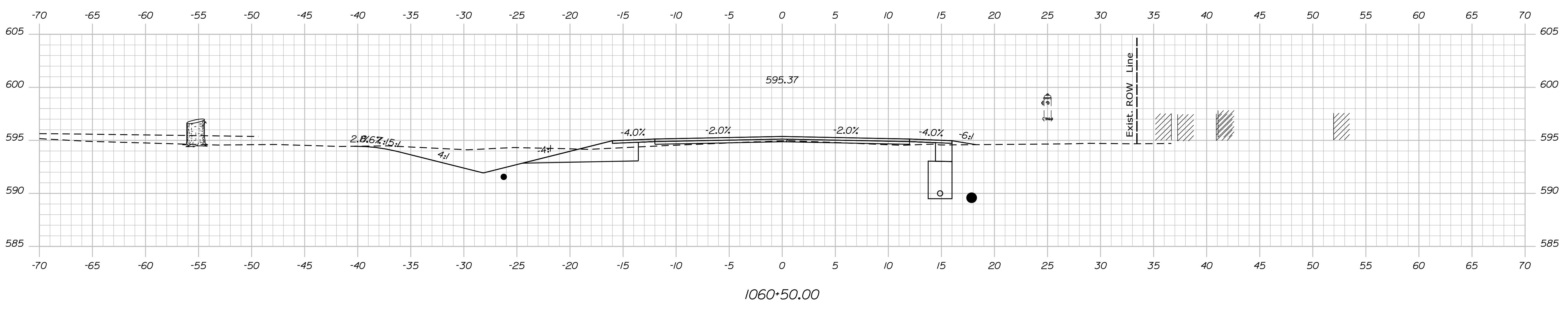
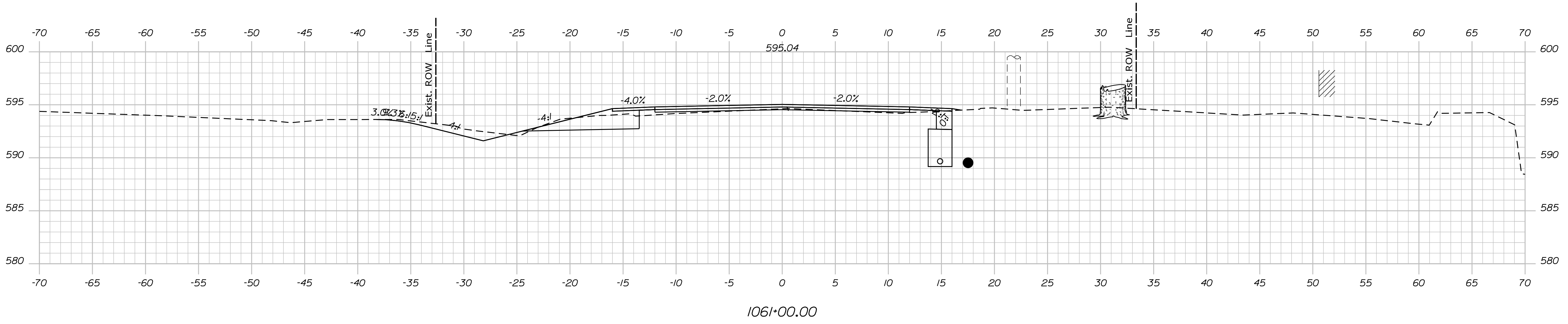

STATE OF MAINE
DEPARTMENT OF TRANSPORTATION
STP-1824(500)
WIN
18245.00
HIERARCHIC PLANS

SIGNATURE
P.E. NUMBER
DATE

PROJ. MANAGER	DATE
DESIGN DETAILED	
CHECKED/REVISED	
DESIGN DETAILED	
DESIGN DETAILED	
REVISIONS 1	
REVISIONS 2	
REVISIONS 3	
REVISIONS 4	
FIELD CHANGES	

KINGFIELD
ROUTE 16\27
CROSS SECTIONS

SHEET NUMBER
Xse
OF 175

Date: \$date\$

Username:

Division: HIGHWAY

Filename: ... \Bentley\ustrn\Xsect.dgn

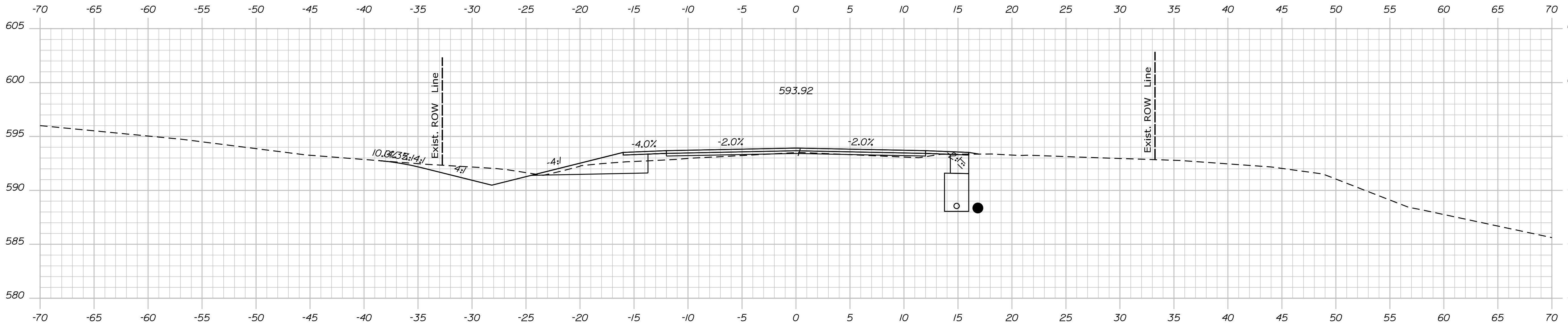

1062+00.00

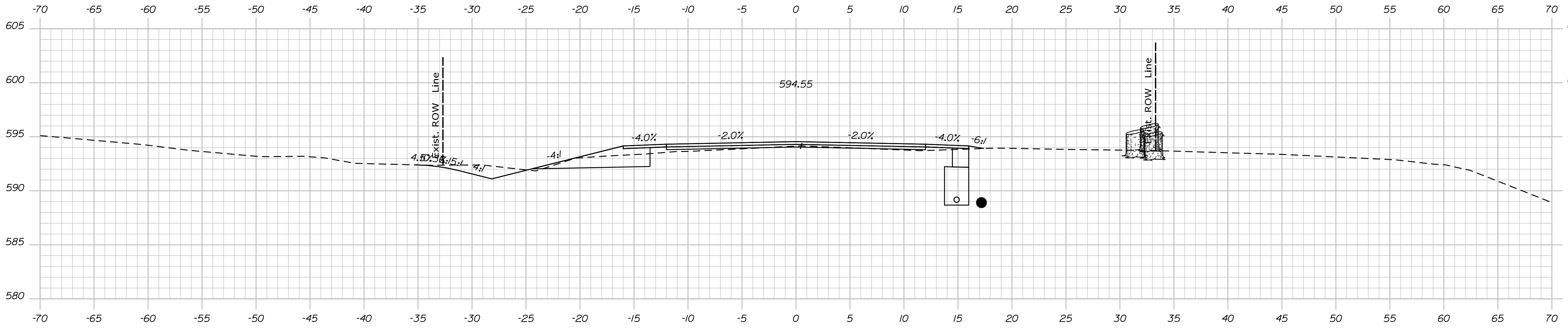

1061+50.00

STATE OF MAINE
DEPARTMENT OF TRANSPORTATION
STP-1824(500)
WIN
18245.00
HIERARCHIC PLANS

SIGNATURE
P.E. NUMBER
DATE

PROJ. MANAGER	DATE
DESIGN DETAILED	
CHECKED/REVIEWED	
DESIGN DETAILED	
DESIGN DETAILED	
REVISIONS 1	
REVISIONS 2	
REVISIONS 3	
REVISIONS 4	
FIELD CHANGES	

KINGFIELD
ROUTE 16\27
CROSS SECTIONS

SHEET NUMBER
Xse
OF 175

Date: \$date\$

Username:

Division: HIGHWAY

Filename: ... \Bentley\ustrn\Xsect.dgn

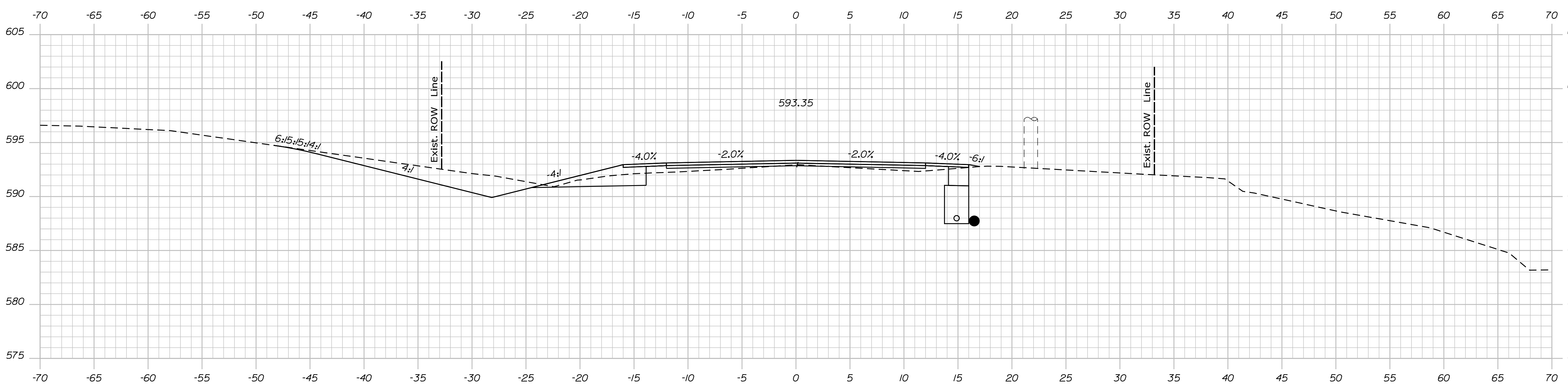
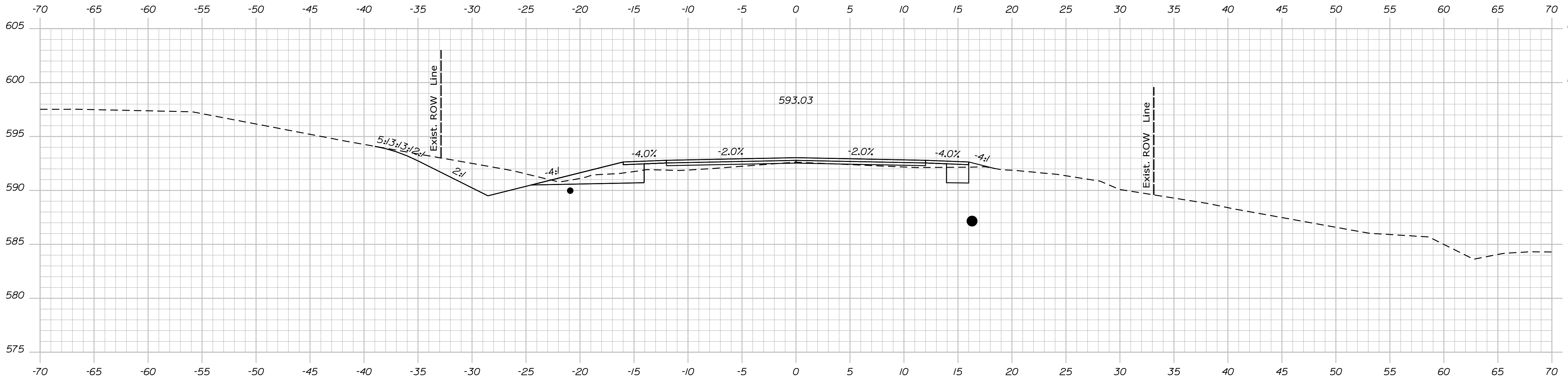

STATE OF MAINE
DEPARTMENT OF TRANSPORTATION
STP-1824(500)
WIN
18245.00
HIERARCHIC PLANS

PROJ. MANAGER	DATE	BY	DATE
DESIGN/DETAILED			
CHECKED/REVIEWED			
DESIGN/DETAILED			
DESIGN/DETAILED			
REVISIONS 1			
REVISIONS 2			
REVISIONS 3			
REVISIONS 4			
FIELD CHANGES			

KINGFIELD
ROUTE 16\27
CROSS SECTIONS

SHEET NUMBER
Xse
OF 175

Date: \$date\$

Username:

Division: HIGHWAY

Filename: ... \Bentley\ustr\Xsect.dgn

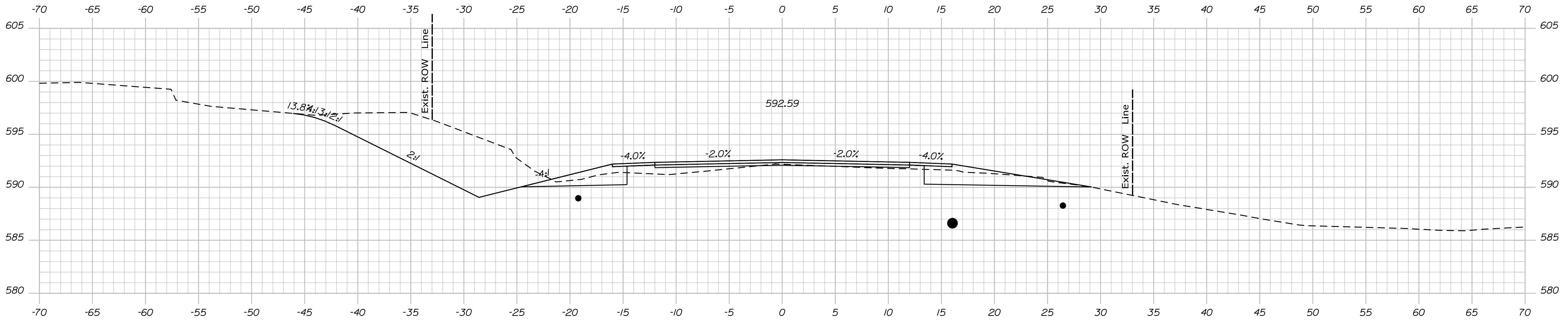

1064+00.00

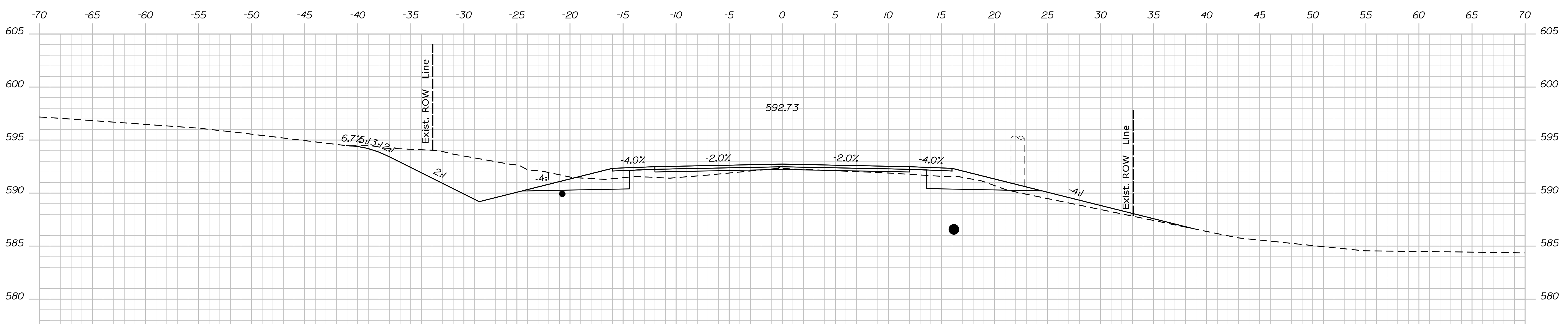

1063+50.00

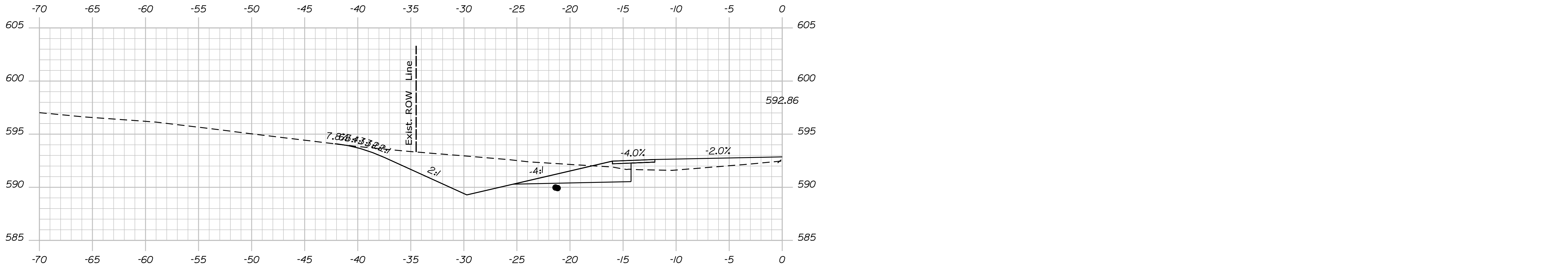

1063+32.00

STATE OF MAINE
DEPARTMENT OF TRANSPORTATION
STP-1824(500)
WIN
18245.00
HIGHWAY PLANS

DESIGN DETAILED	SIGNATURE
CHECKED/REVIEWED	P.E. NUMBER
DESIGN DETAILED	DATE
DESIGN DETAILED	
REVISIONS 1	
REVISIONS 2	
REVISIONS 3	
REVISIONS 4	
FIELD CHANGES	

PROJ. MANAGER	DATE
BY	
PROJ. MANAGER	
BY	
PROJ. MANAGER	
BY	
PROJ. MANAGER	
BY	

KINGFIELD
ROUTE 16\27
CROSS SECTIONS

SHEET NUMBER
Xse
OF 175

Date: \$date\$

Username:

Division: HIGHWAY

Filename: ... \Bentley\ustr\Xsect.dgn

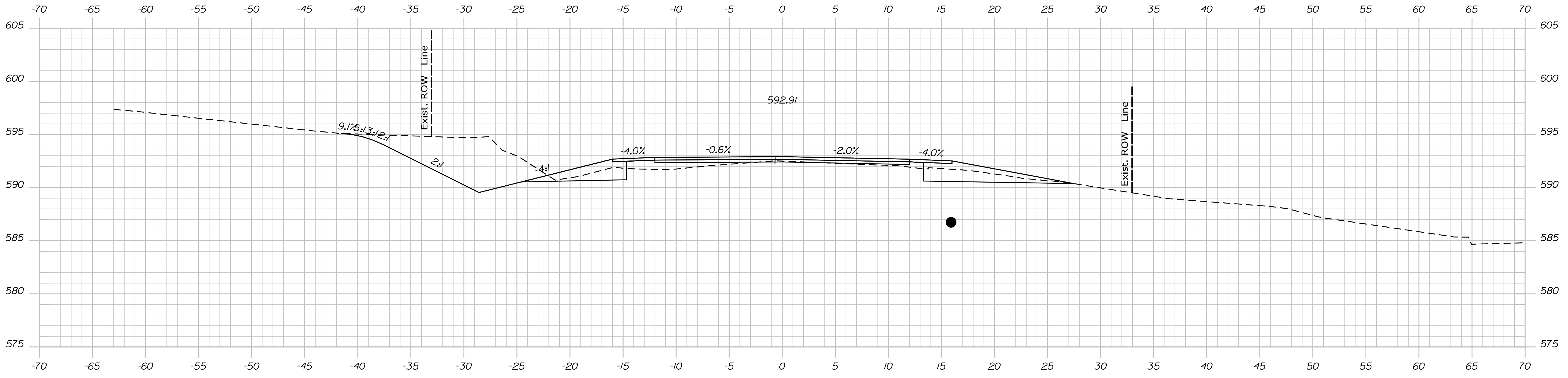

1064+50.00

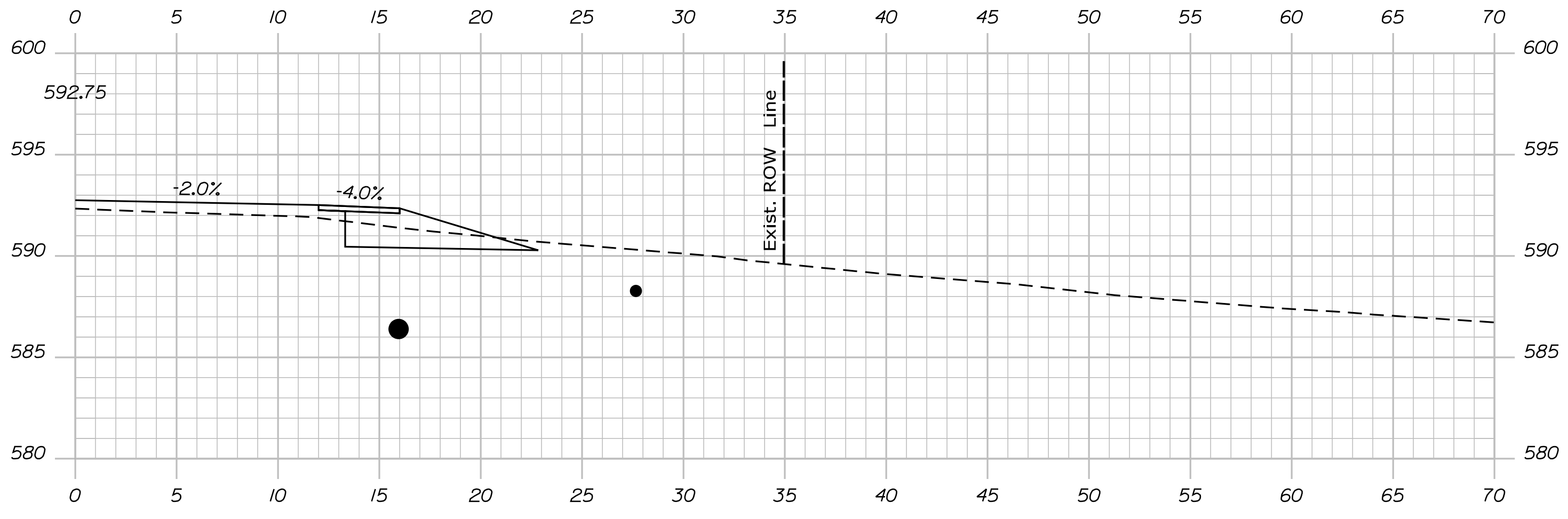

1064+35.00

STATE OF MAINE
DEPARTMENT OF TRANSPORTATION
STP-1824(500)

WIN
18245.00
HIERARCHIC PLANS

SIGNATURE
P.E. NUMBER
DATE

PROJ. MANAGER	DATE
DESIGN DETAILED	
CHECKED/REVIEWED	
DESIGN DETAILED	
DESIGN DETAILED	
REVISIONS 1	
REVISIONS 2	
REVISIONS 3	
REVISIONS 4	
FIELD CHANGES	

**KINGFIELD
ROUTE 16\27
CROSS SECTIONS**

SHEET NUMBER

Xse

OF 175

Date: \$date\$

Username:

Division: HIGHWAY

Filename: ... \Bentley\ustrn\Xsect.dgn

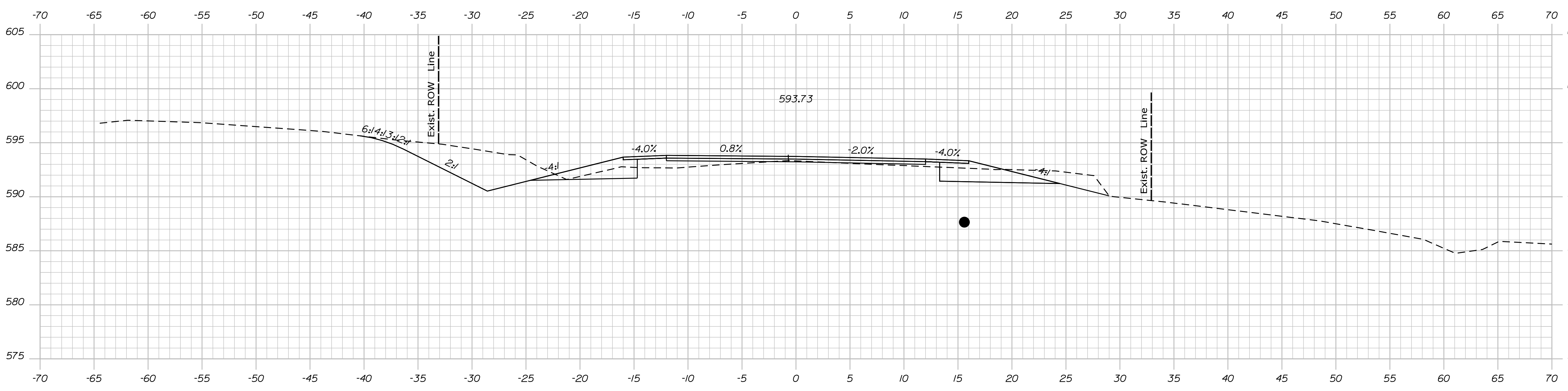
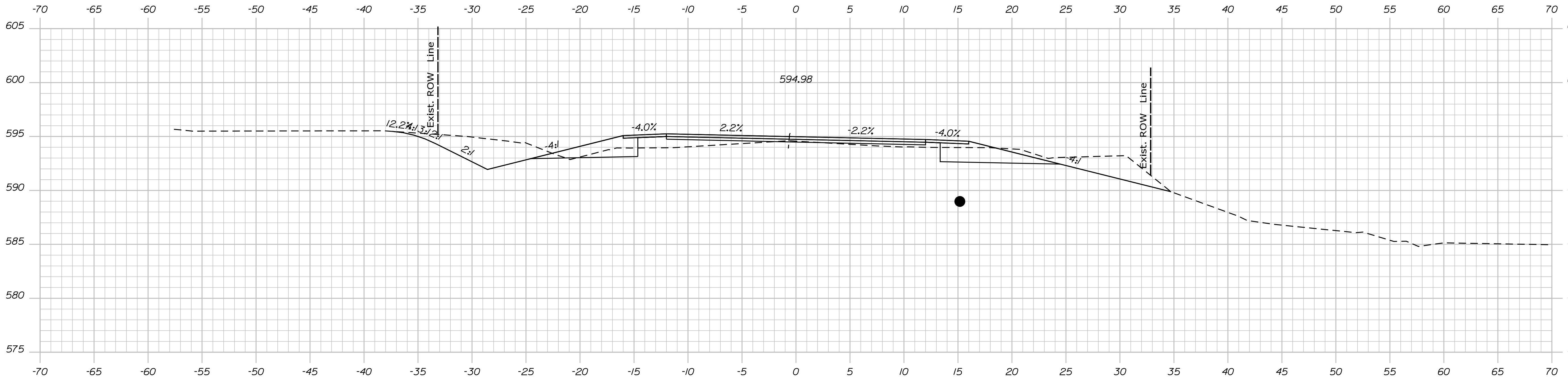

STATE OF MAINE
DEPARTMENT OF TRANSPORTATION
STP-1824(500)
WIN
18245.00
HIERARCHIC PLANS

PROJ. MANAGER	BY	DATE	SIGNATURE	P.E. NUMBER	DATE
DESIGN DETAILED					
CHECKED/REVIEWED					
DESIGN DETAILED					
DESIGN DETAILED					
REVISIONS 1					
REVISIONS 2					
REVISIONS 3					
REVISIONS 4					
FIELD CHANGES					

KINGFIELD
ROUTE 16\27
CROSS SECTIONS

SHEET NUMBER
Xse
OF 175

Date: \$date\$

Username:

Division: HIGHWAY

Filename: ... \Bentley\ustrn\Xsect.dgn

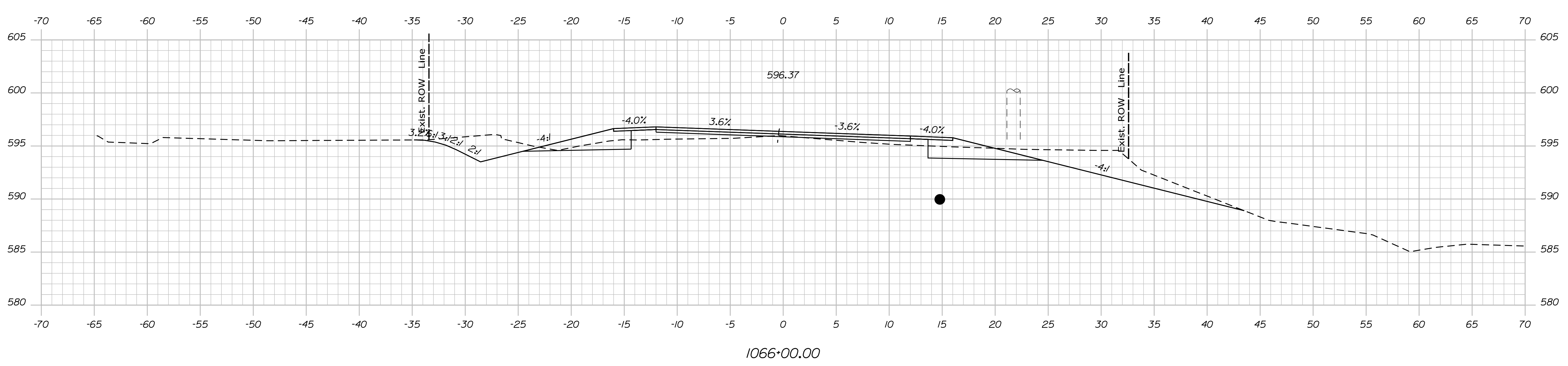
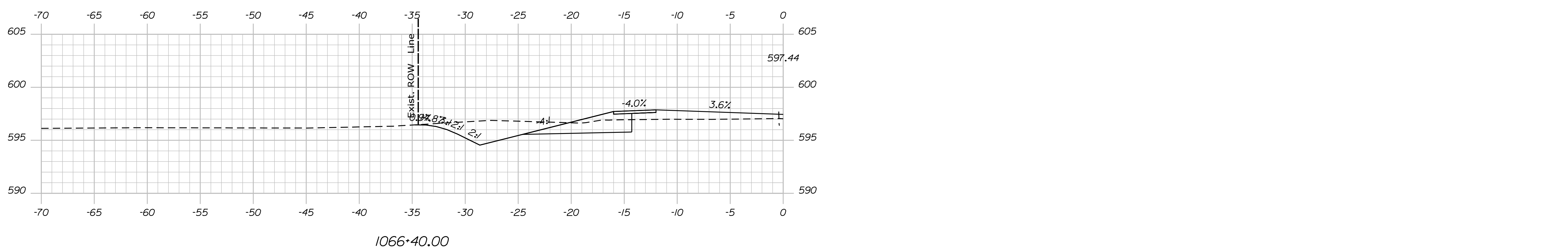
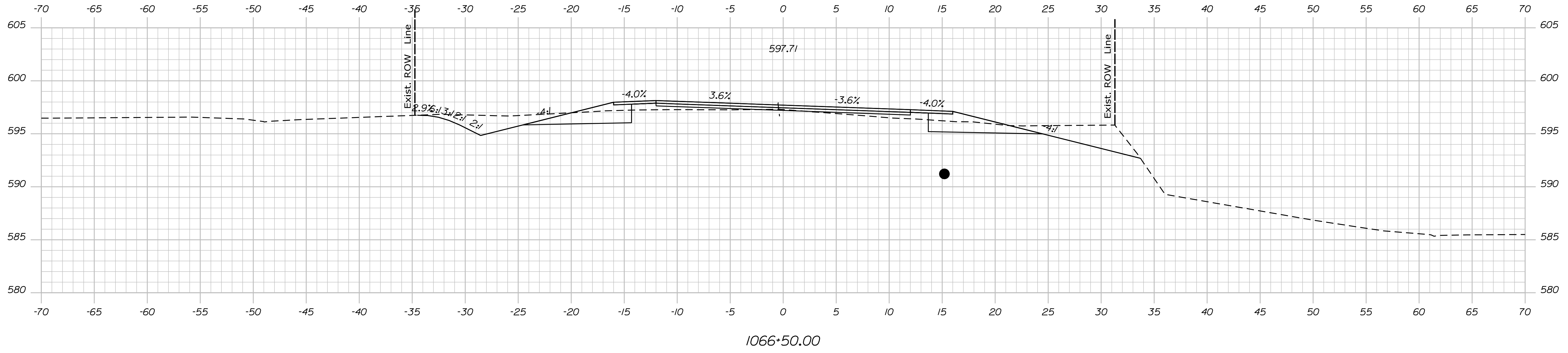

STATE OF MAINE
 DEPARTMENT OF TRANSPORTATION
 STP-1824(500)
 WIN
 18245.00
 HIERARCHIC PLANS

SIGNATURE
 P.E. NUMBER
 DATE

PROJ. MANAGER	DATE
DESIGN DETAILED	
CHECKED/REVIEWED	
DESIGN DETAILED	
DESIGN DETAILED	
REVISIONS 1	
REVISIONS 2	
REVISIONS 3	
REVISIONS 4	
FIELD CHANGES	

KINGFIELD
 ROUTE 16\27
 CROSS SECTIONS

SHEET NUMBER
Xse
 OF 175

Date: \$date\$

Username:

Division: HIGHWAY

Filename: ... \Bentley\ustrn\Xsect.dgn

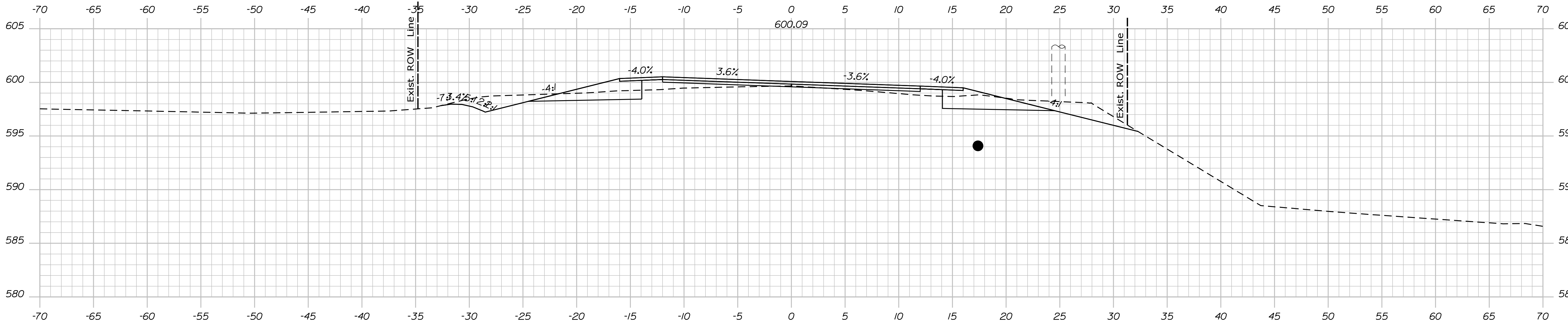

1068+00.00

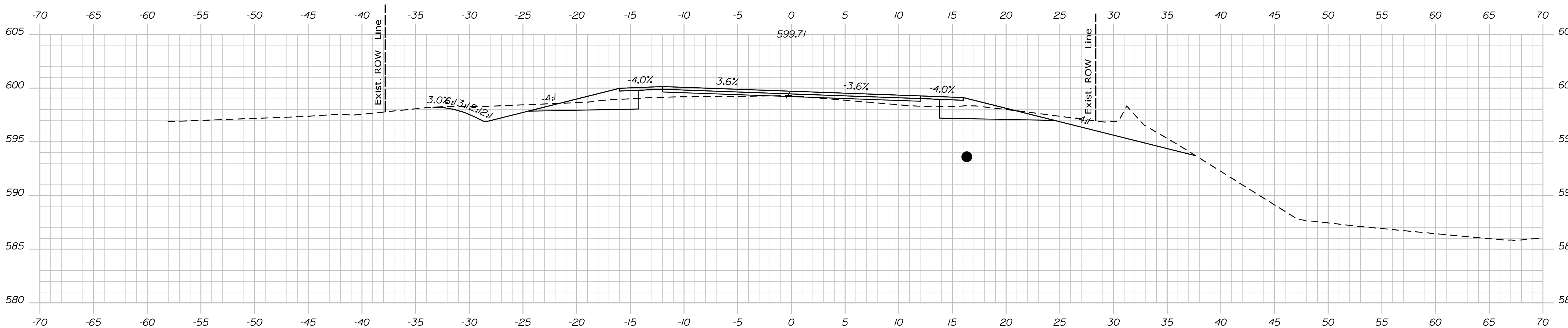

1067+50.00

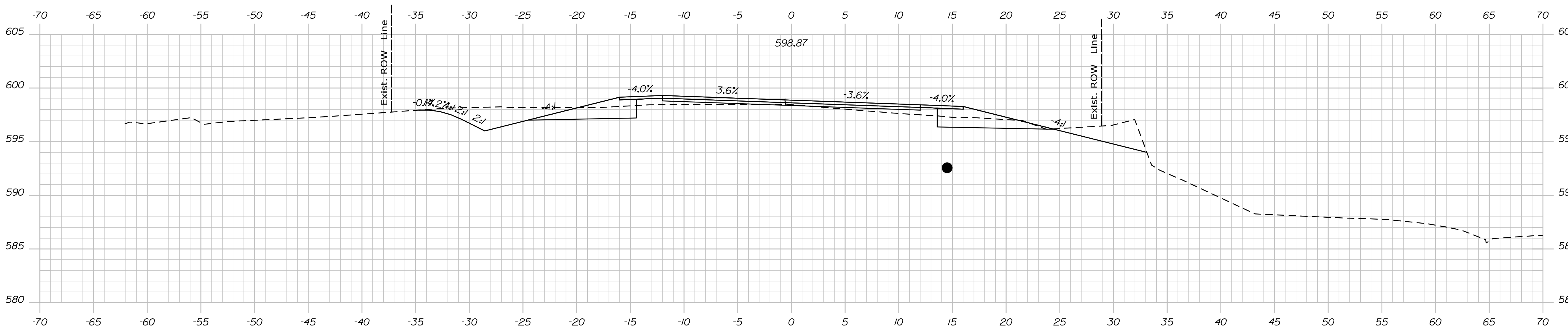

1067+00.00

STATE OF MAINE
DEPARTMENT OF TRANSPORTATION
STP-1824(500)
WIN
18245.00
HIERARCHIC PLANS

PROJ. MANAGER \$PROJMANAGER\$
CHECKED/REVIEWED
DESIGN DETAILED
DESIGN DETAILED
REVISIONS 1
REVISIONS 2
REVISIONS 3
REVISIONS 4
FIELD CHANGES

DATE	BY	SIGNATURE	P.E. NUMBER	DATE

KINGFIELD
ROUTE 16\27
CROSS SECTIONS

SHEET NUMBER
Xse
OF 175

Date: \$date\$

Username:

Division: HIGHWAY

Filename: ... \Bentley\ustrn\Xsect.dgn

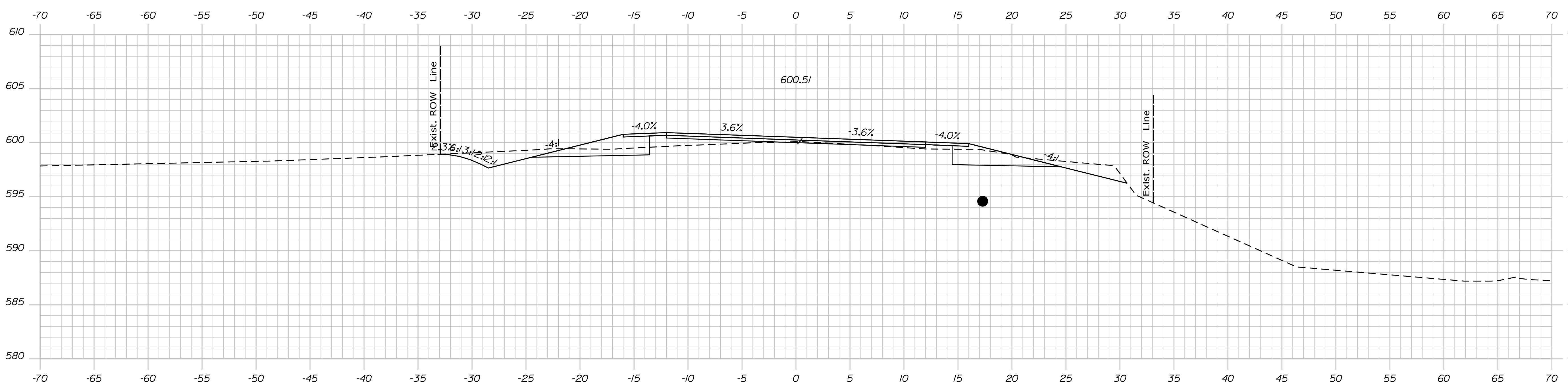
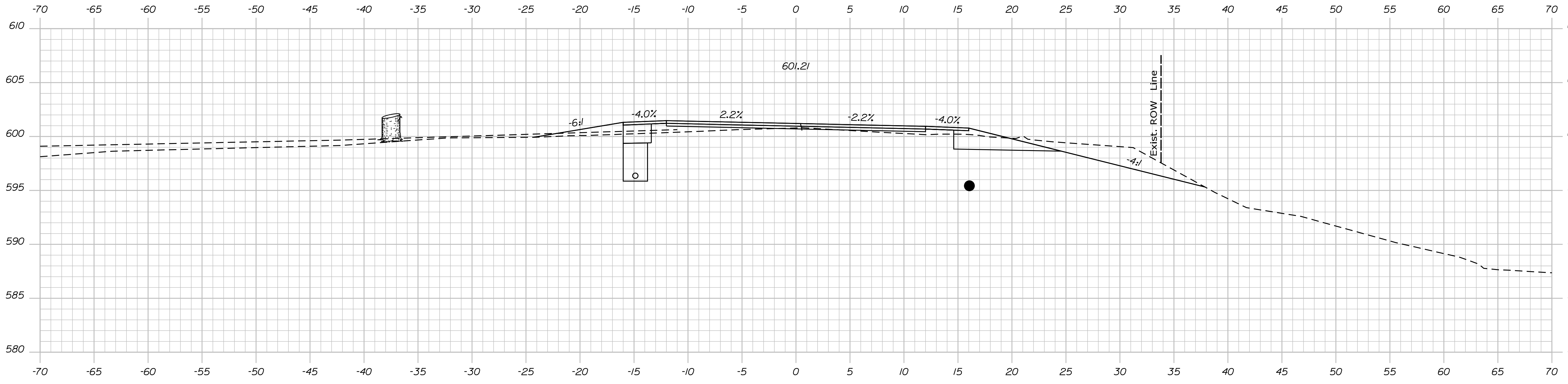

STATE OF MAINE
DEPARTMENT OF TRANSPORTATION
STP-1824(500)
WIN
18245.00
HIERARCHIC PLANS

SIGNATURE
P.E. NUMBER
DATE

PROJ. MANAGER	DATE
DESIGN/DETAILED	
CHECKED/REVISED	
DESIGN/DETAILED	
DESIGN/DETAILED	
REVISIONS 1	
REVISIONS 2	
REVISIONS 3	
REVISIONS 4	
FIELD CHANGES	

KINGFIELD
ROUTE 16\27
CROSS SECTIONS

SHEET NUMBER
Xse
OF 175

Date: \$date\$

Username:

Division: HIGHWAY

Filename: ... \Bentley\ustrn\Xsect.dgn

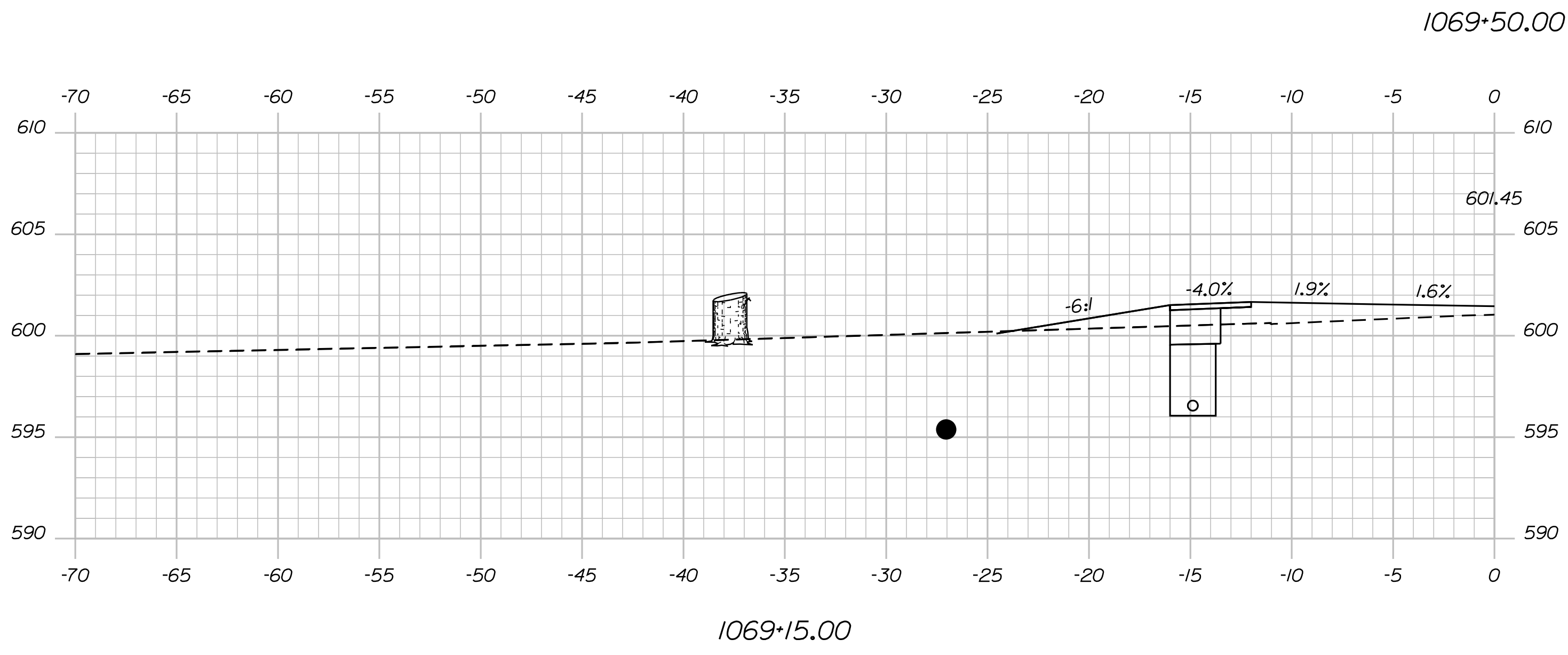
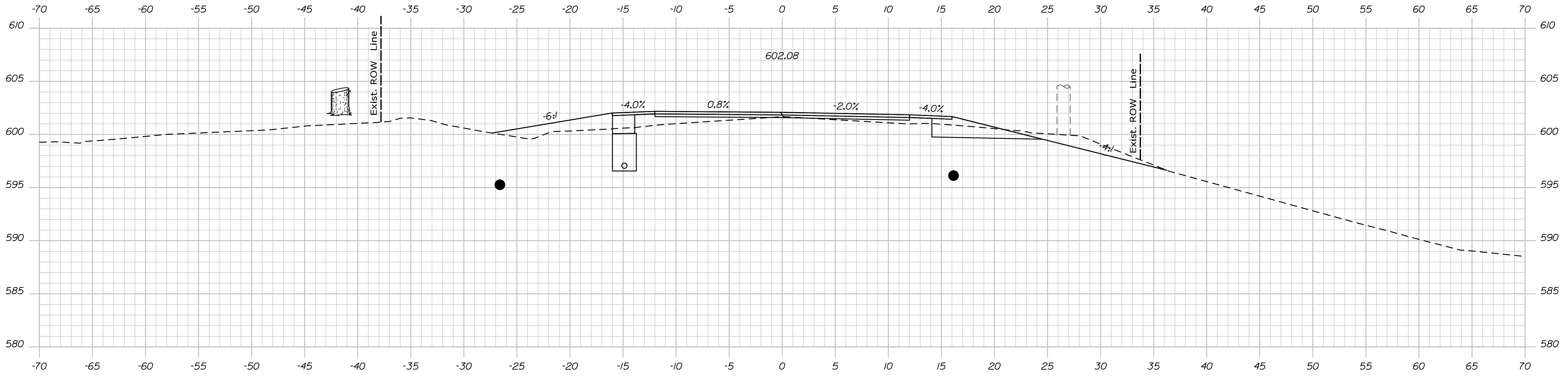

STATE OF MAINE
DEPARTMENT OF TRANSPORTATION
STP-1824(500)
WIN
18245.00
HIERARCHIC PLANS

SIGNATURE
P.E. NUMBER
DATE

PROJ. MANAGER	DATE
DESIGN DETAILED	
CHECKED/REVIEWED	
DESIGN DETAILED	
DESIGN DETAILED	
REVISIONS 1	
REVISIONS 2	
REVISIONS 3	
REVISIONS 4	
FIELD CHANGES	

KINGFIELD
ROUTE 16\27
CROSS SECTIONS

SHEET NUMBER
Xse
OF 175

Date: \$date\$

Username:

Division: HIGHWAY

Filename: ... \Bentley\ustrn\Xsect.dgn

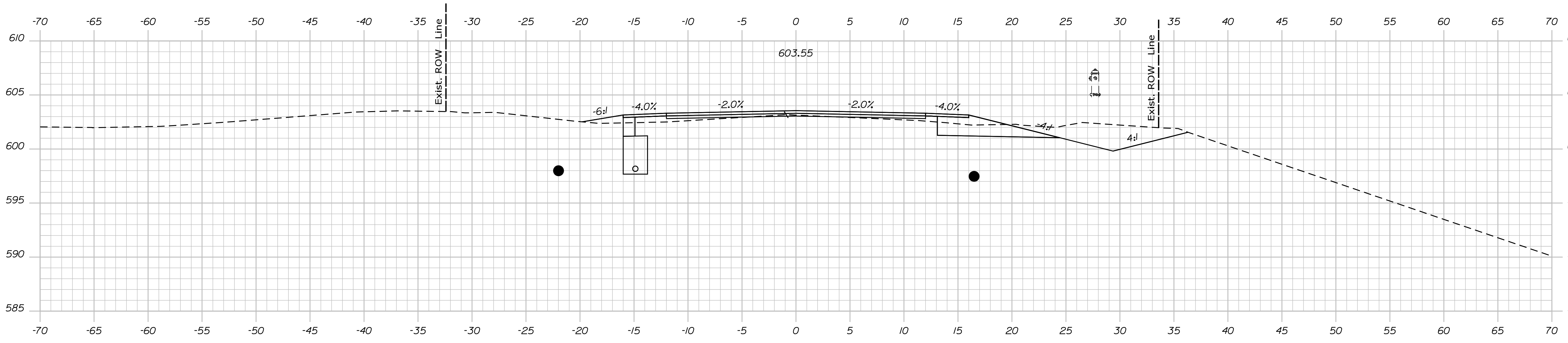

1070+50.00

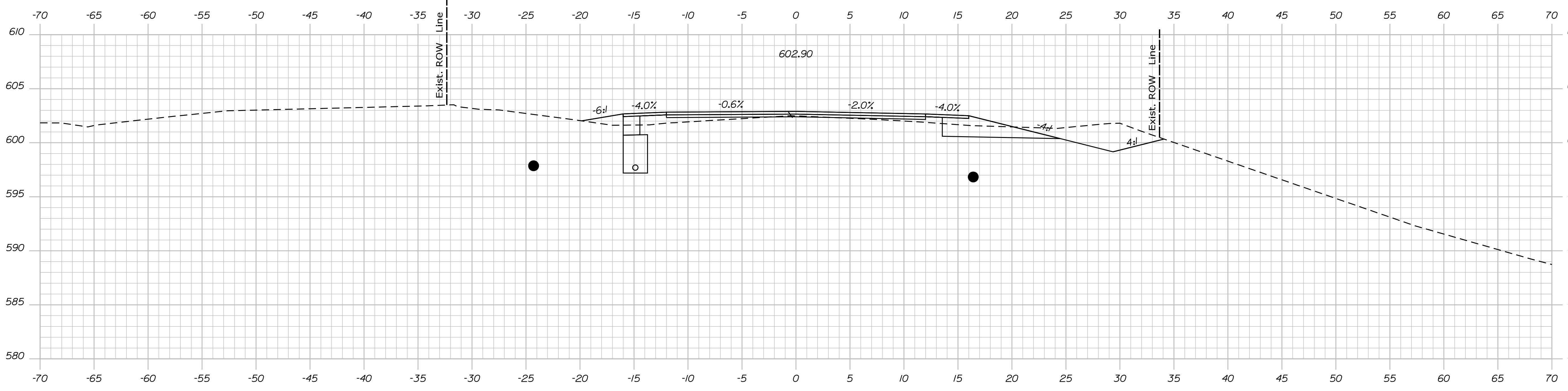

1070+00.00

STATE OF MAINE
DEPARTMENT OF TRANSPORTATION
STP-1824(500)
WIN
18245.00
HIERARCHIC PLANS

SIGNATURE
P.E. NUMBER
DATE

PROJ. MANAGER	DATE
DESIGN DETAILER	
CHECKED/REVIEWED	
DESIGN DETAILER	
DESIGN DETAILER	
REVISIONS 1	
REVISIONS 2	
REVISIONS 3	
REVISIONS 4	
FIELD CHANGES	

KINGFIELD
ROUTE 16\27
CROSS SECTIONS

SHEET NUMBER
Xse
OF 175

Date: \$date\$

Username:

Division: HIGHWAY

Filename: ... \Bentley\ustrn\Xsect.dgn

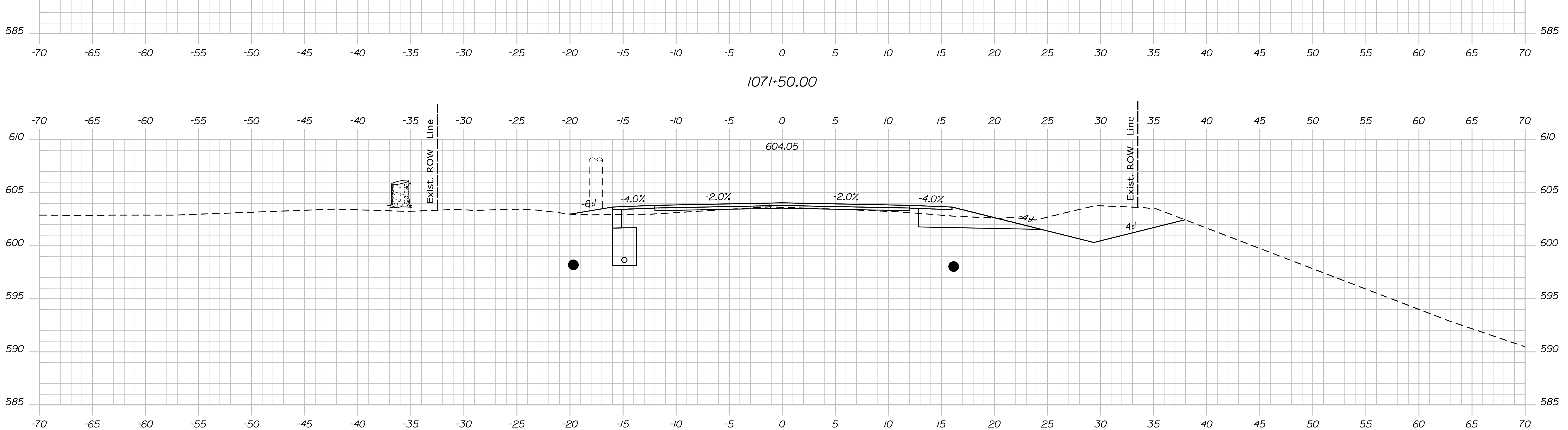
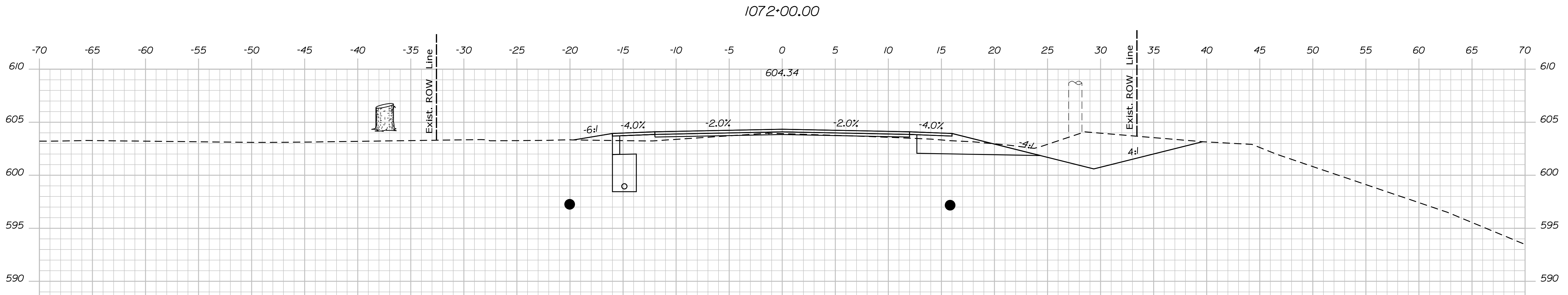
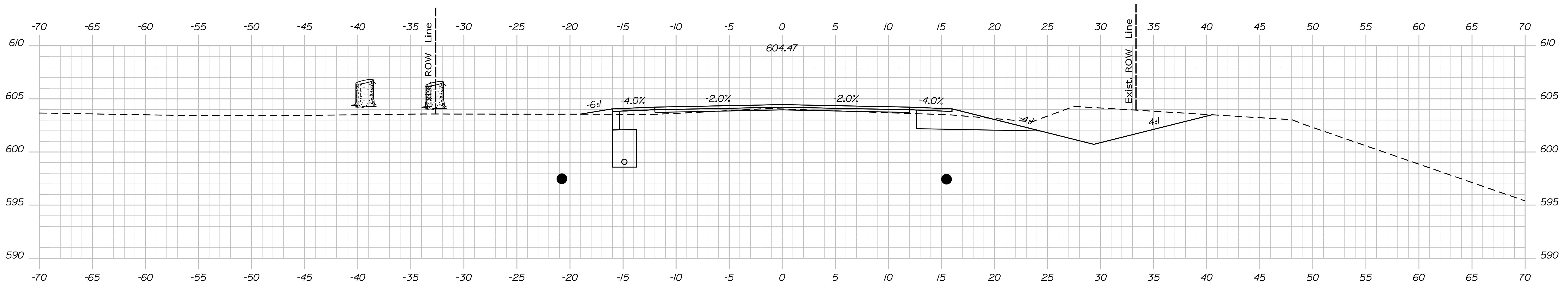

STATE OF MAINE
DEPARTMENT OF TRANSPORTATION
STP-1824(500)
WIN
18245.00
HIERARCHIC PLANS

PROJ. MANAGER	DATE	BY	SIGNATURE

KINGFIELD
ROUTE 16\27
CROSS SECTIONS

SHEET NUMBER
Xse
OF 175

Date: \$date\$

Username:

Division: HIGHWAY

Filename: ... \Bentley\ustrn\Xsect.dgn

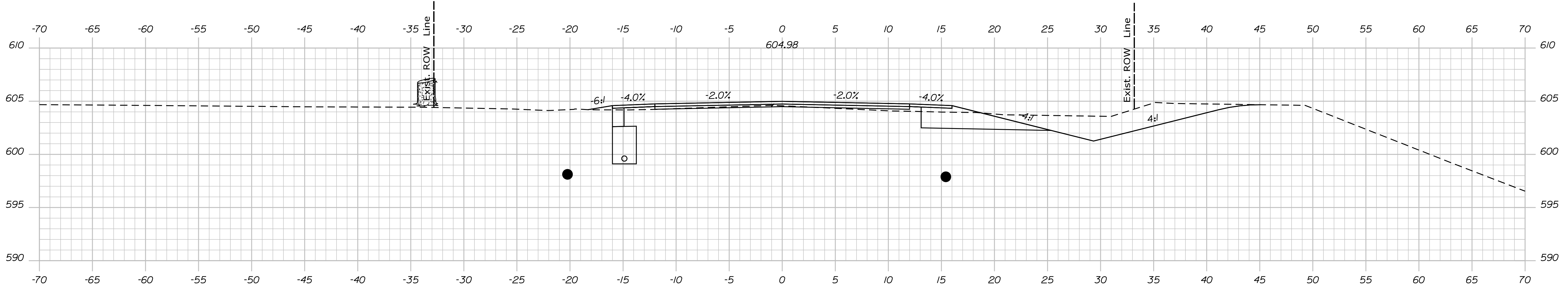

1073+00.00

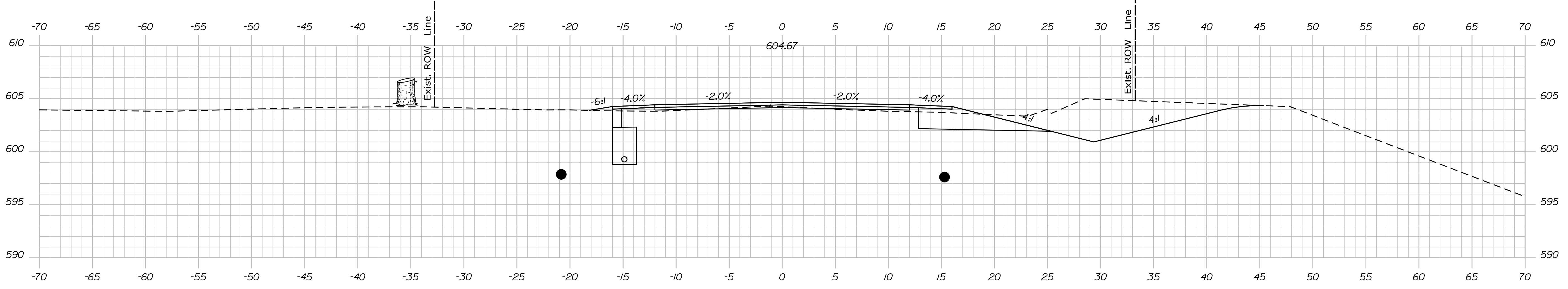

1072+50.00

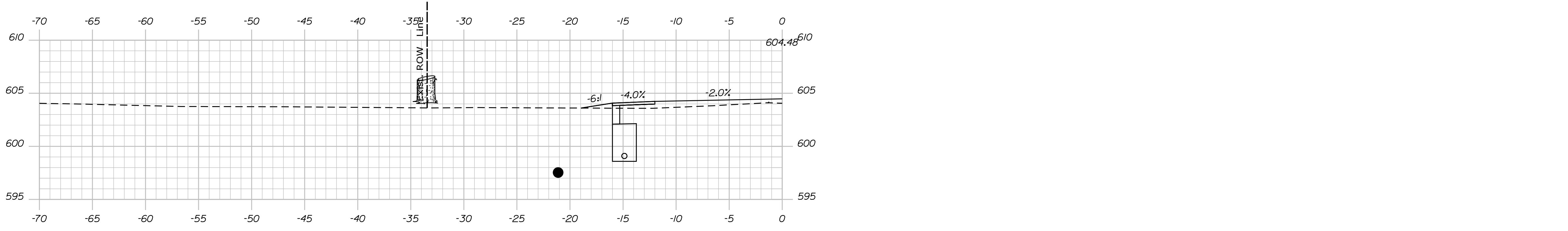

1072+07.00

STATE OF MAINE
DEPARTMENT OF TRANSPORTATION
STP-1824(500)
WIN
18245.00
HIERARCHIC PLANS

SIGNATURE
P.E. NUMBER
DATE

PROJ. MANAGER	DATE
DESIGN DETAILED	
CHECKED/REVIEWED	
DESIGN DETAILED	
DESIGN DETAILED	
REVISIONS 1	
REVISIONS 2	
REVISIONS 3	
REVISIONS 4	
FIELD CHANGES	

KINGFIELD
ROUTE 16\27
CROSS SECTIONS

SHEET NUMBER
Xse
OF 175

Date: \$date\$

Username:

Division: HIGHWAY

Filename: ... \Bentley\ustrn\Xsect.dgn

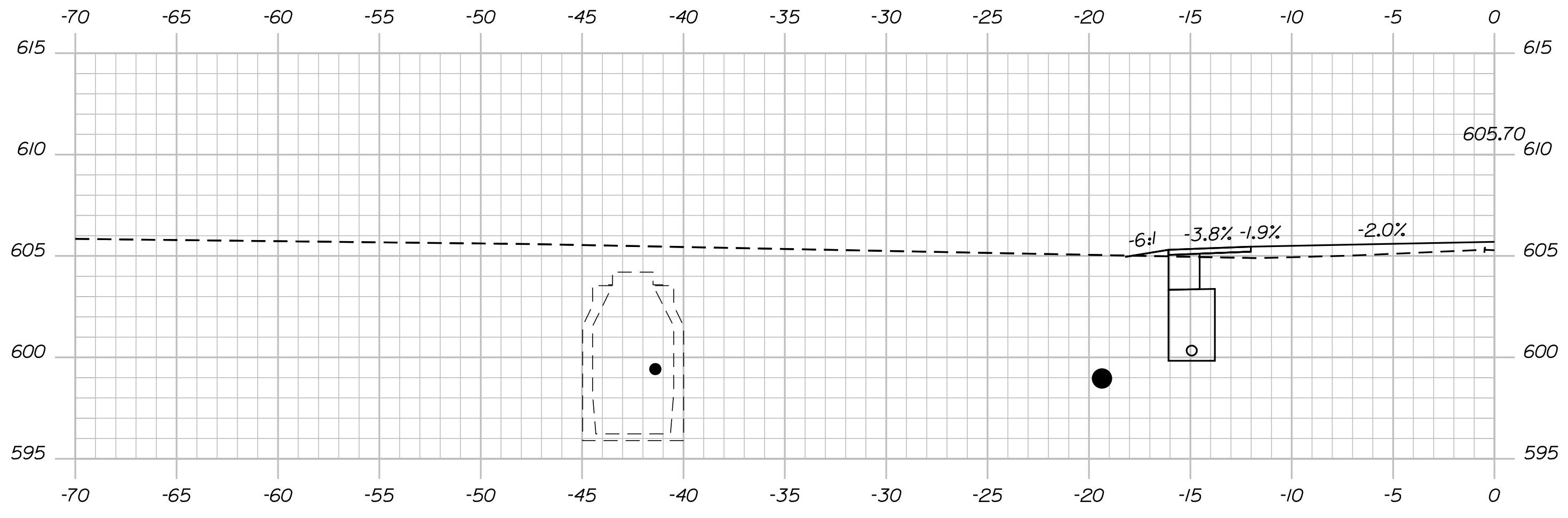

1074+06.00

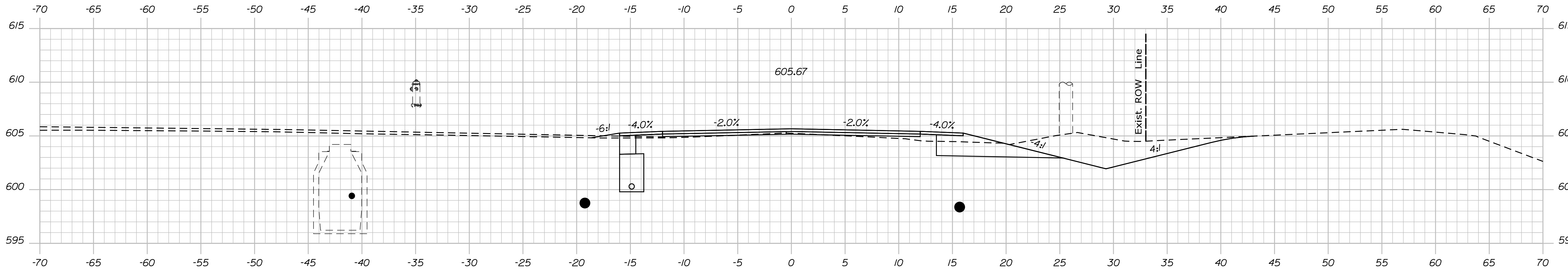

1074+00.00

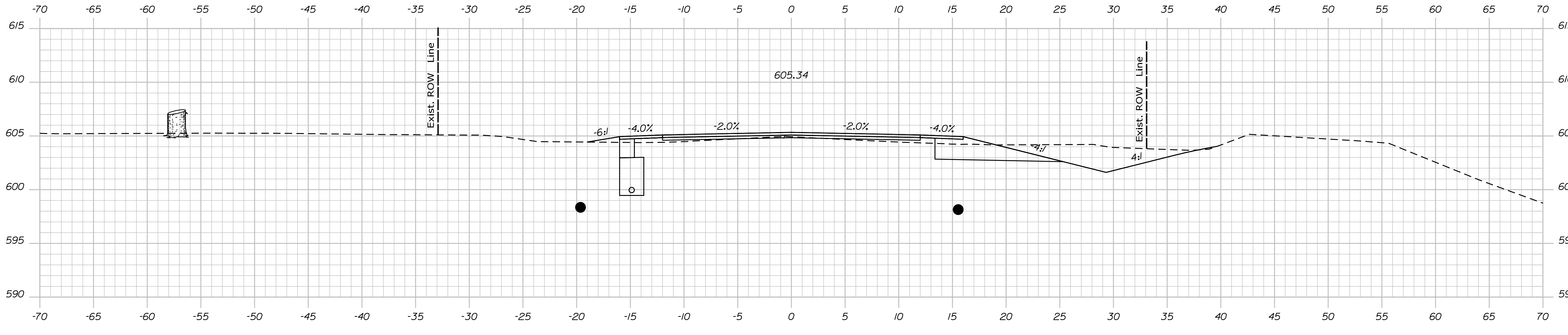

1073+50.00

STATE OF MAINE
DEPARTMENT OF TRANSPORTATION
STP-1824(500)
WIN
18245.00
HIERARCHIC PLANS

PROJ. MANAGER	BY	DATE
DESIGN DETAILED		
CHECKED/REVISED		
DESIGN DETAILED		
DESIGN DETAILED		
REVISIONS 1		
REVISIONS 2		
REVISIONS 3		
REVISIONS 4		
FIELD CHANGES		

KINGFIELD
ROUTE 16\27
CROSS SECTIONS

SHEET NUMBER
Xse
OF 175

Date: \$date\$

Username:

Division: HIGHWAY

Filename: ... \Bentley\ustrn\Xsect.dgn

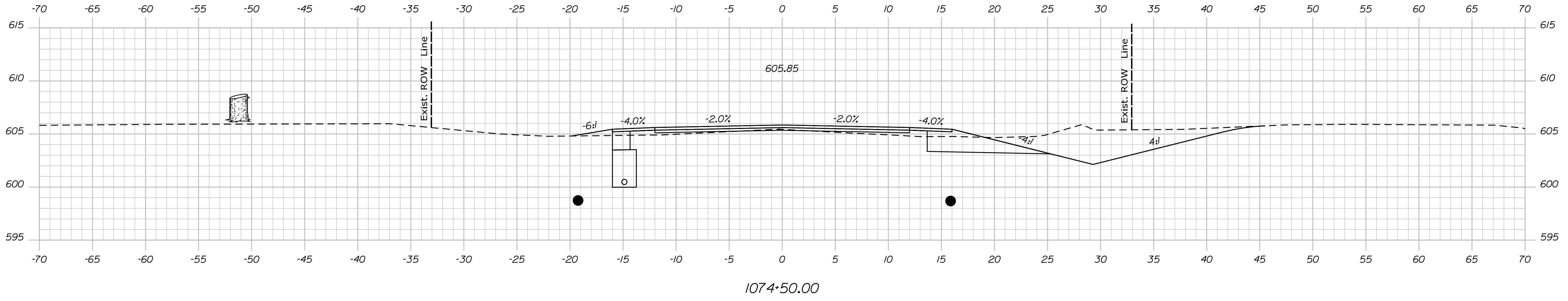
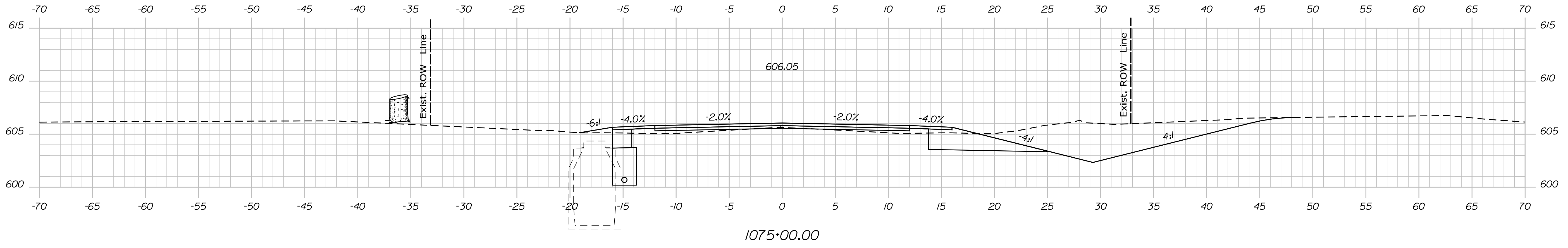
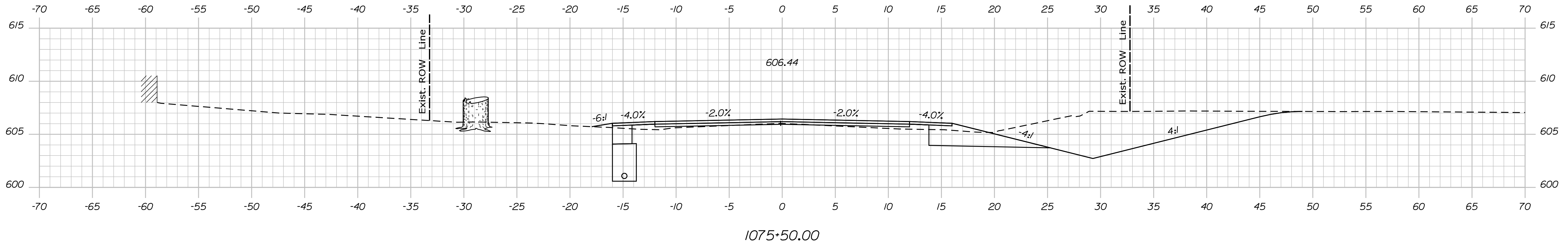
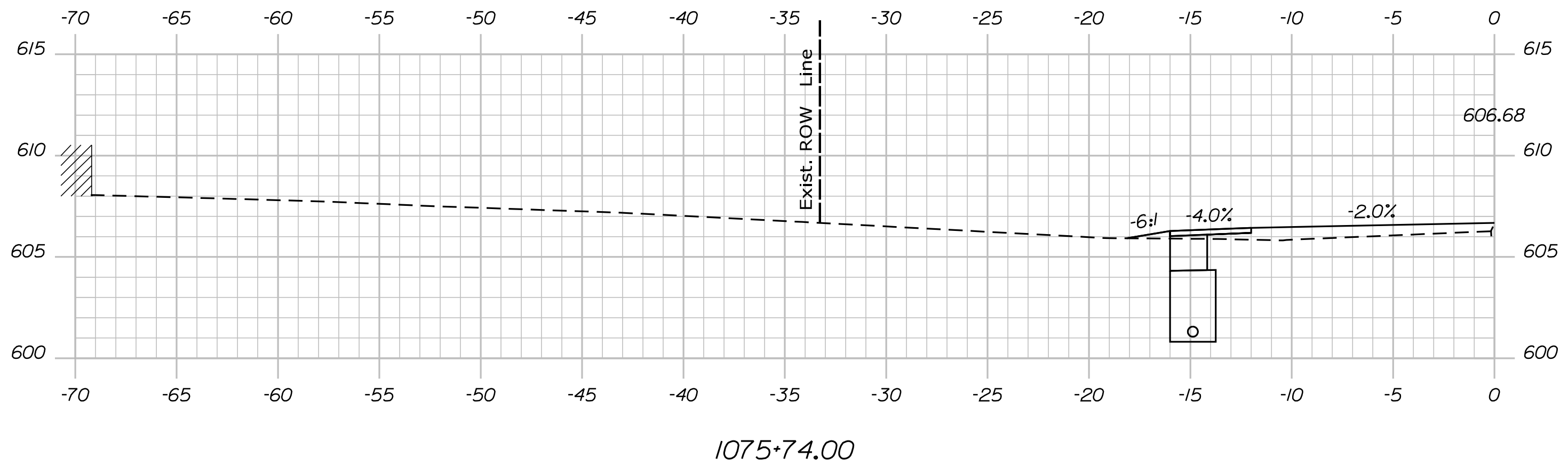

STATE OF MAINE
DEPARTMENT OF TRANSPORTATION
STP-1824(500)
WIN
18245.00
HIERARCHIC PLANS

SIGNATURE	P.E. NUMBER	DATE
-----------	-------------	------

PROJ. MANAGER	DATE
DESIGNED/TAILED	
CHECKED/REVISED	
DESIGNED/TAILED	
DESIGNED/TAILED	
REVISIONS 1	
REVISIONS 2	
REVISIONS 3	
REVISIONS 4	
FIELD CHANGES	

KINGFIELD
ROUTE 16\27
CROSS SECTIONS

SHEET NUMBER
Xse
OF 175

Date: \$date\$

Username:

Division: HIGHWAY

Filename: ... \Bentley\ustrn\Xsect.dgn

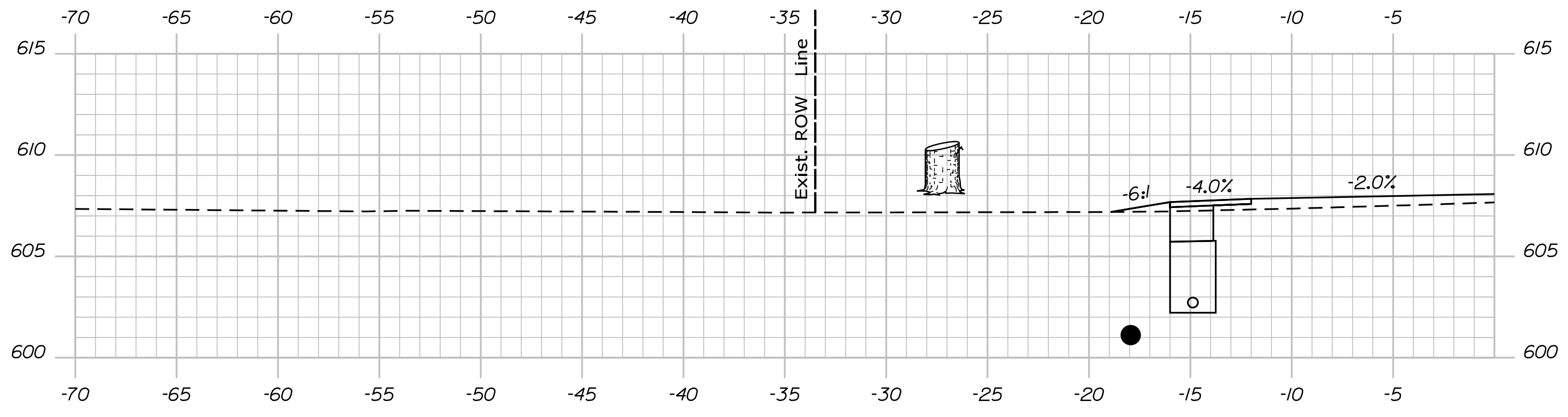

1077+14.00

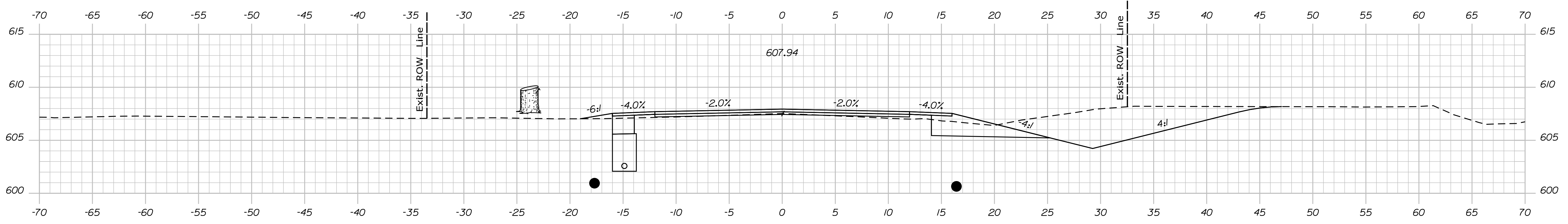

1077+00.00

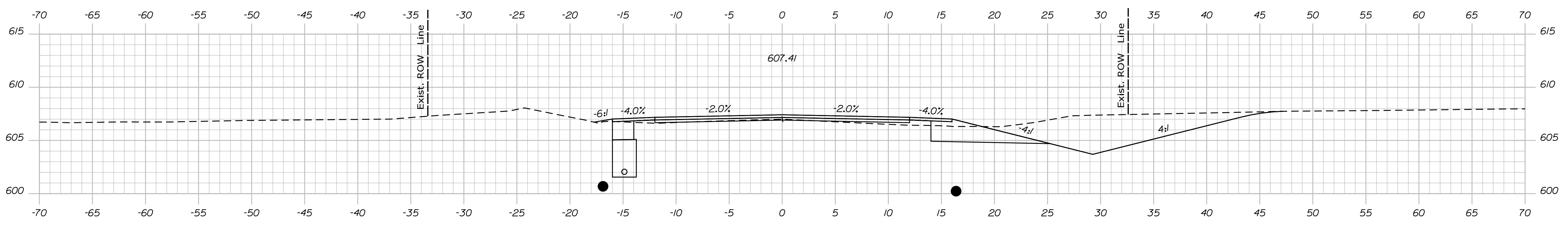

1076+50.00

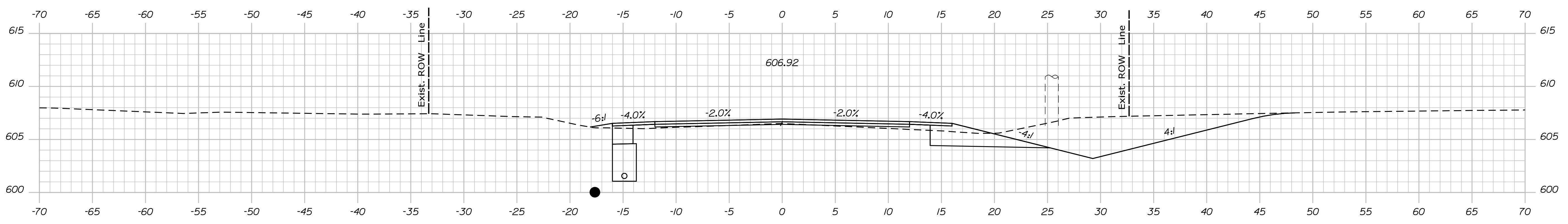

1076+00.00

STATE OF MAINE
DEPARTMENT OF TRANSPORTATION
STP-1824(500)
WIN
18245.00
HIERARCHIC PLANS

DESIGN/DATE
CHECKED/REVIEWED
DESIGNED/DATE
DESIGNED/DATE
REVISIONS 1
REVISIONS 2
REVISIONS 3
REVISIONS 4
FIELD CHANGES

PROJ. MANAGER \$PROJMANAGER\$
BY
DATE
SIGNATURE
P.E. NUMBER
DATE

KINGFIELD
ROUTE 16\27
CROSS SECTIONS

SHEET NUMBER
Xse
OF 175

Date: \$date\$

Username:

Division: HIGHWAY

Filename: ... \Bentley\ustrn\Xsect.dgn

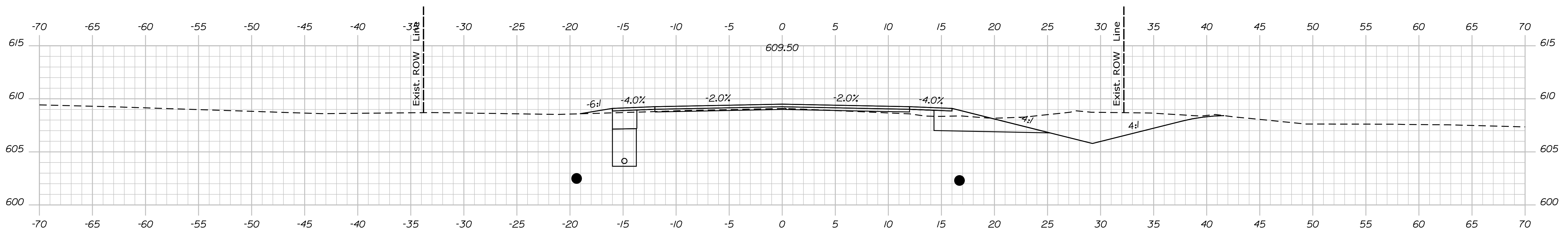

1079+00.00

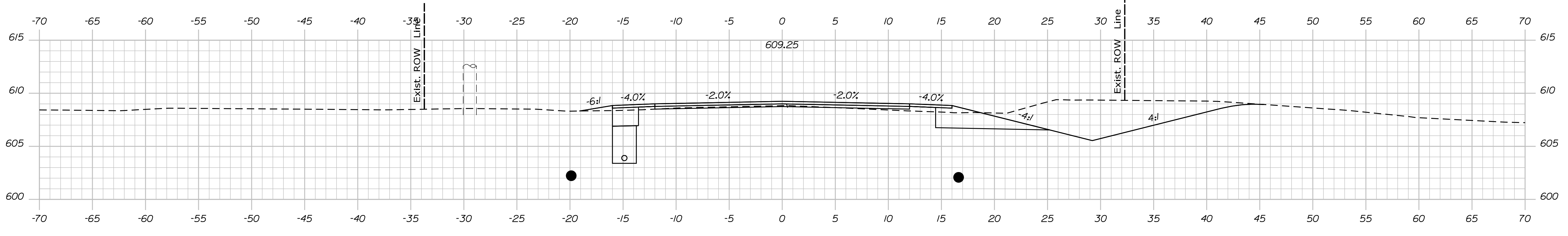

1078+50.00

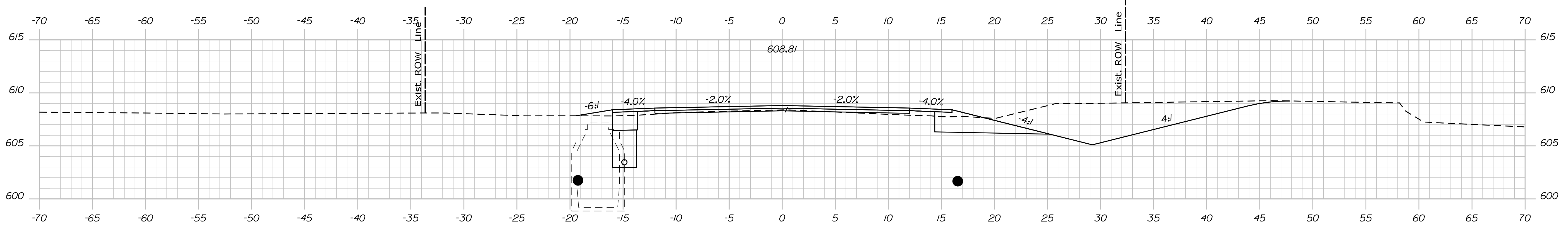

1078+00.00

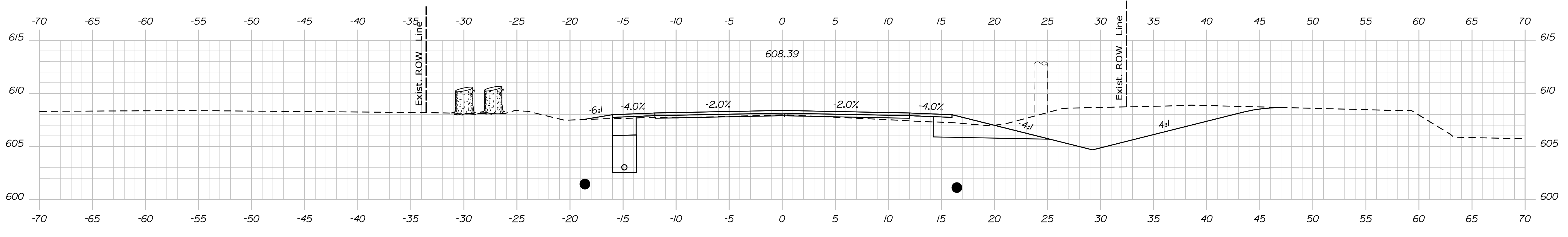

1077+50.00

STATE OF MAINE
DEPARTMENT OF TRANSPORTATION
STP-1824(500)
WIN
18245.00
HIERARCHIC PLANS

PROJ. MANAGER	DATE
CHECKED/REVIEWED	SIGNATURE
DESIGNED/TAILED	P.E. NUMBER
DESIGNED/TAILED	DATE
REVISIONS 1	
REVISIONS 2	
REVISIONS 3	
REVISIONS 4	
FIELD CHANGES	

KINGFIELD
ROUTE 16\27
CROSS SECTIONS

SHEET NUMBER
Xse
OF 175

Date: \$date\$

Username:

Division: HIGHWAY

Filename: ... \Bentley\ustrn\Xsect.dgn

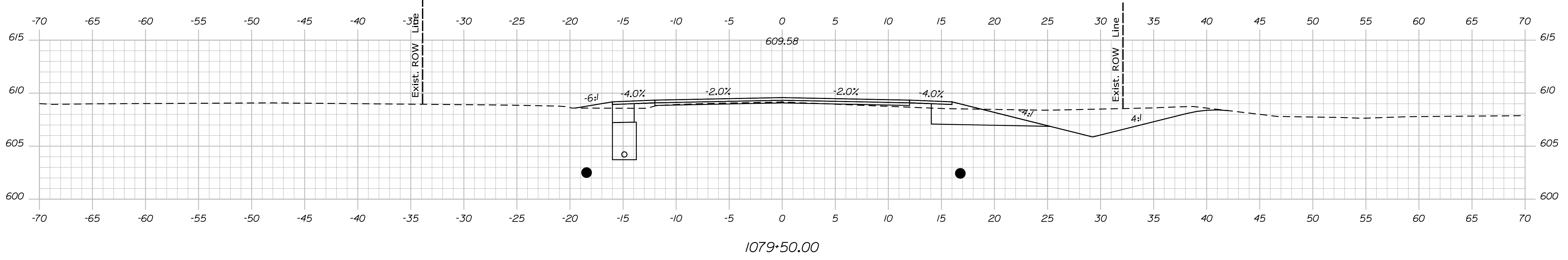
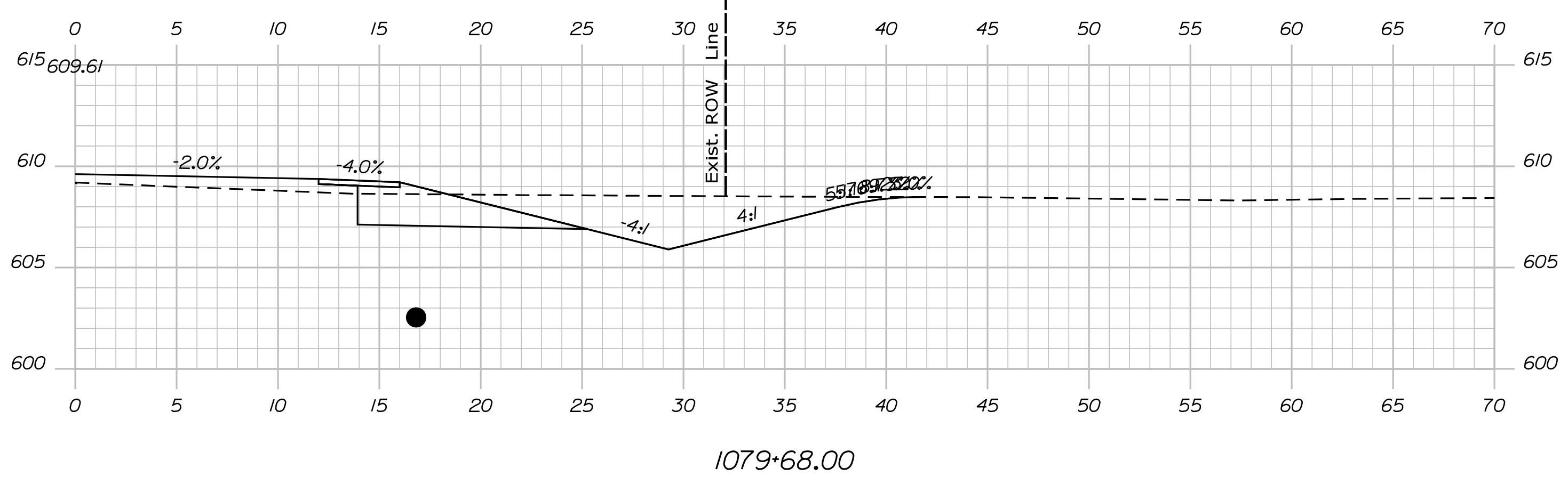
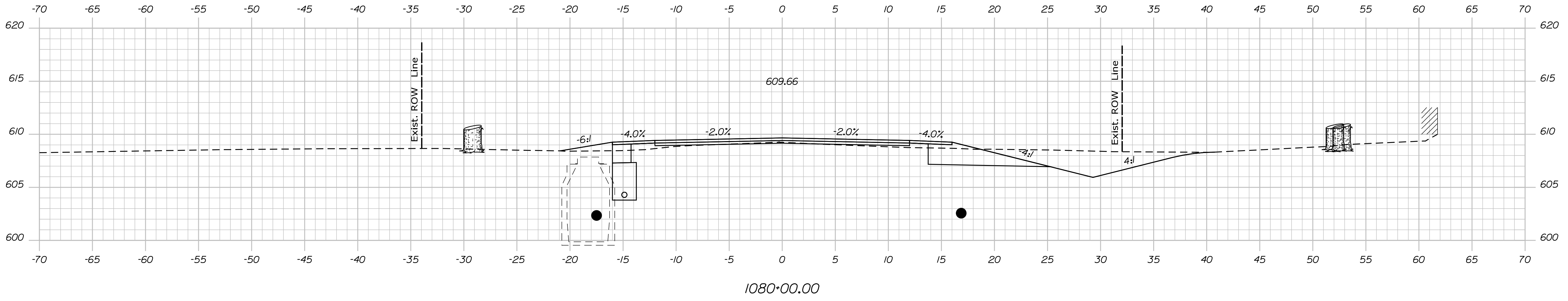
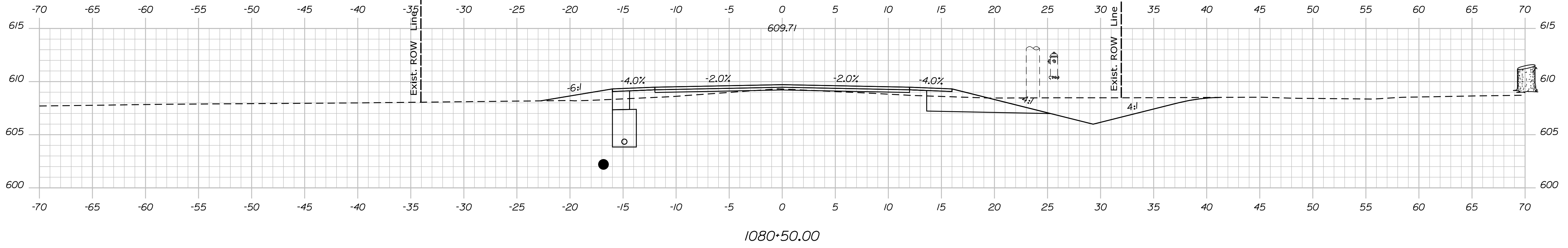

STATE OF MAINE
DEPARTMENT OF TRANSPORTATION
STP-1824(500)
WIN
18245.00
HIERARCHIC PLANS

SIGNATURE
P.E. NUMBER
DATE

PROJ. MANAGER	DATE
DESIGN DETAILER	
CHECKED/REVIEWED	
DESIGN DETAILER	
DESIGN DETAILER	
REVISIONS 1	
REVISIONS 2	
REVISIONS 3	
REVISIONS 4	
FIELD CHANGES	

KINGFIELD
ROUTE 16\27
CROSS SECTIONS

SHEET NUMBER
Xse
OF 175

Date: \$date\$

Username:

Division: HIGHWAY

Filename: ... \Bentley\ustrn\Xsect.dgn

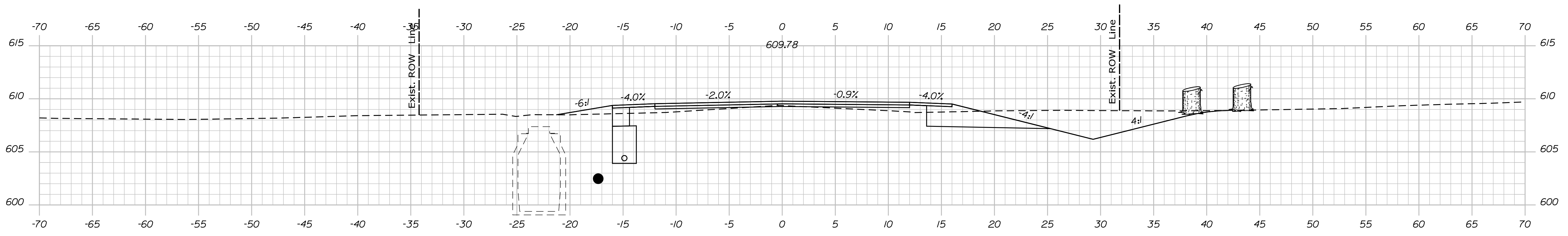

1081+50.00

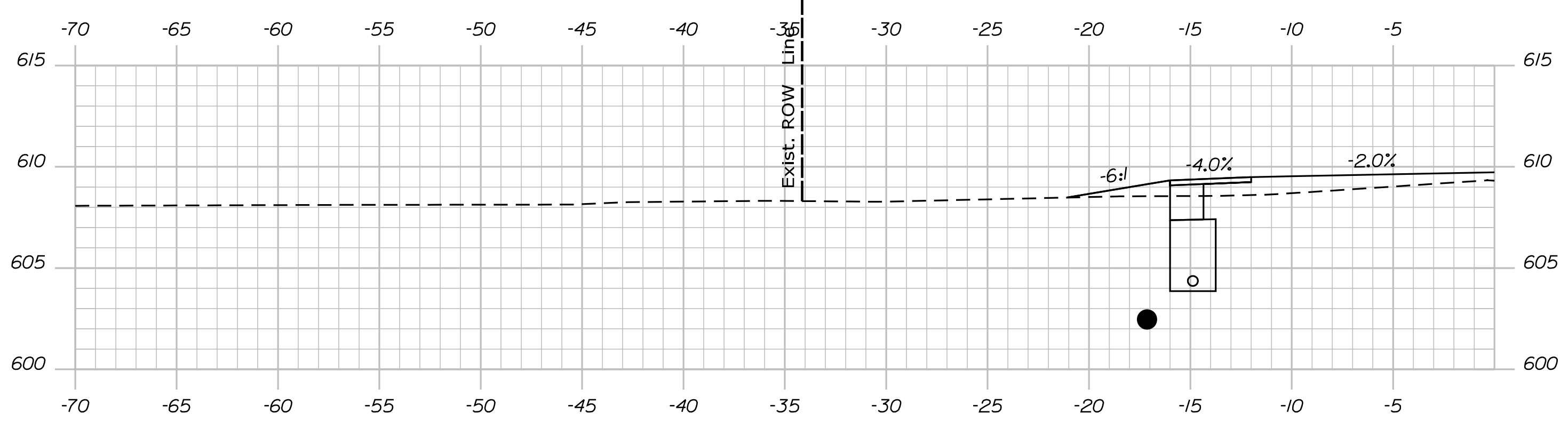

1081+09.00

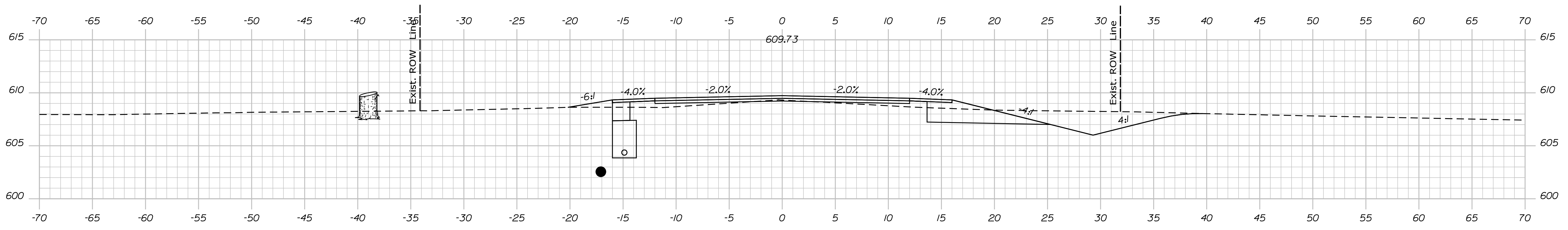

1081+00.00

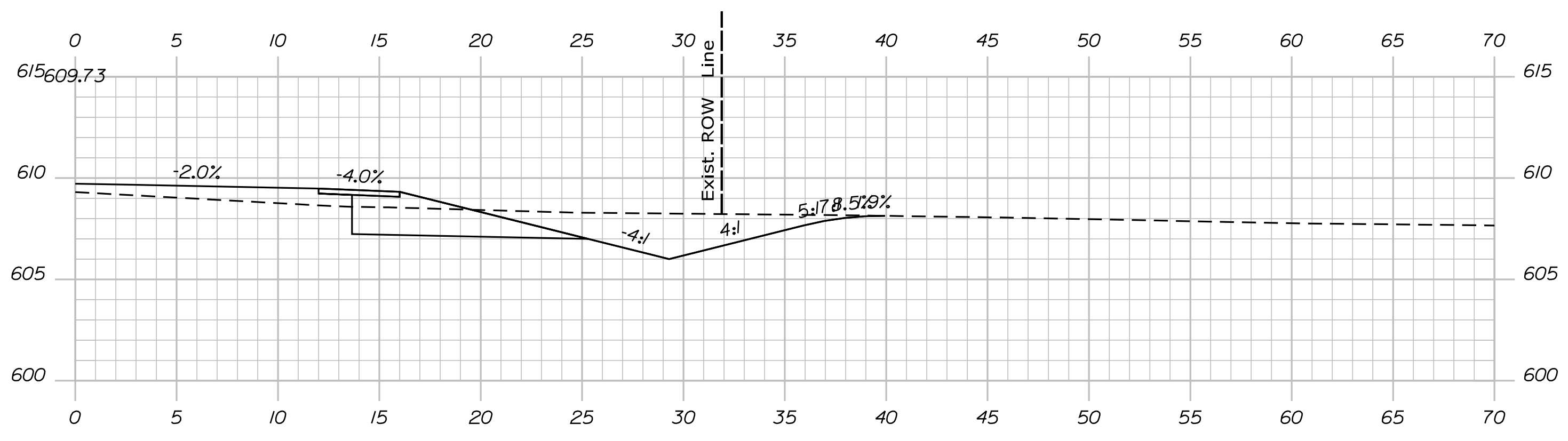

1080+88.00

STATE OF MAINE
DEPARTMENT OF TRANSPORTATION
STP-1824(500)
WIN
18245.00
HIERARCHIC PLANS

DESIGN DETAILED	PROJ. MANAGER	DATE
CHECKED/REVIEWED	BY	DATE
DESIGN DETAILED		
DESIGN DETAILED		
REVISIONS 1		
REVISIONS 2		
REVISIONS 3		
REVISIONS 4		
FIELD CHANGES		

SIGNATURE	
P.E. NUMBER	
DATE	

KINGFIELD
ROUTE 16\27
CROSS SECTIONS

SHEET NUMBER
Xse
OF 175

Date: \$date\$

Username:

Division: HIGHWAY

Filename: ... \Bentley\ustrn\Xsect.dgn

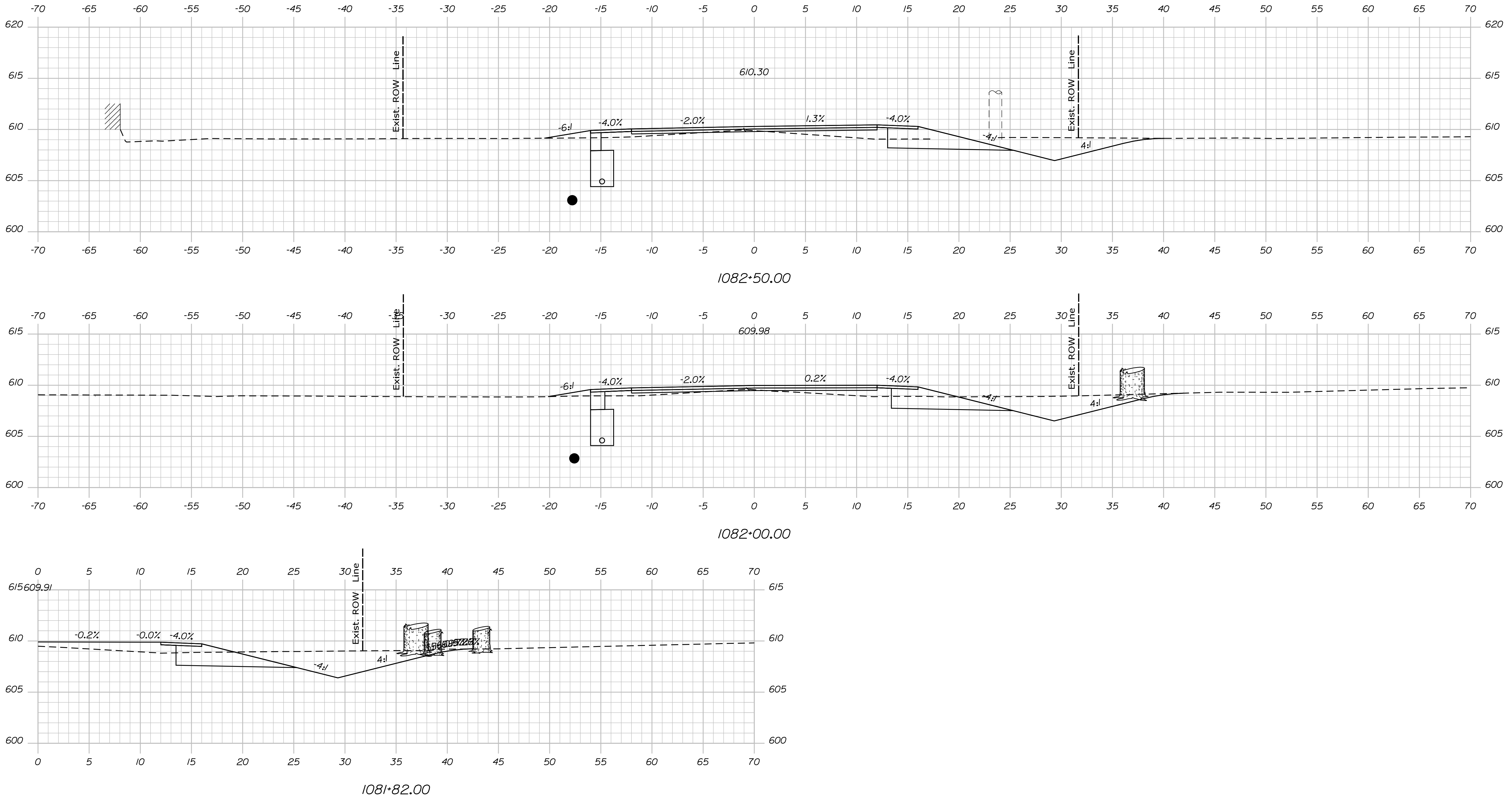

STATE OF MAINE
 DEPARTMENT OF TRANSPORTATION
 STP-1824(500)
 WIN
 18245.00
 HIGHWAY PLANS

PROJ. MANAGER	DATE	BY	DATE
DESIGN DETAIL			
CHECKED/REVISED			
DESIGN DETAIL			
DESIGN DETAIL			
REVISIONS 1			
REVISIONS 2			
REVISIONS 3			
REVISIONS 4			
FIELD CHANGES			

KINGFIELD
 ROUTE 16\27
 CROSS SECTIONS

SHEET NUMBER
Xse
 OF 175

Date: \$date\$

Username:

Division: HIGHWAY

Filename: ... \Bentley\ustrn\Xsect.dgn

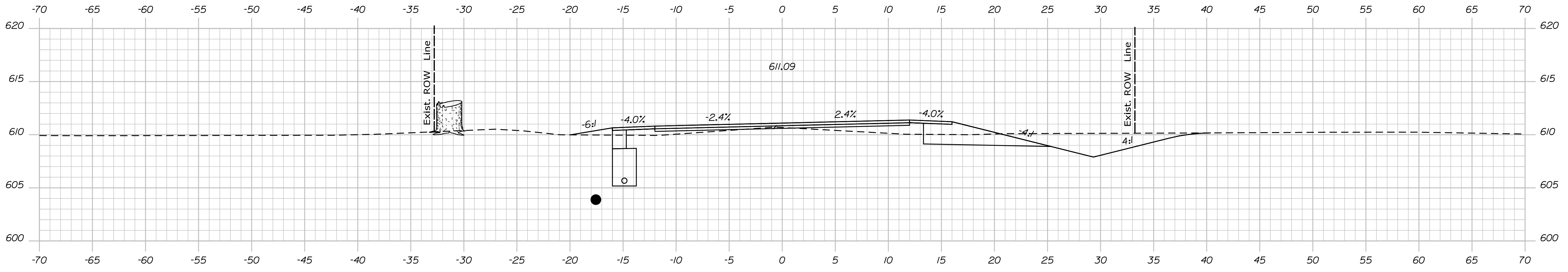

1083+50.00

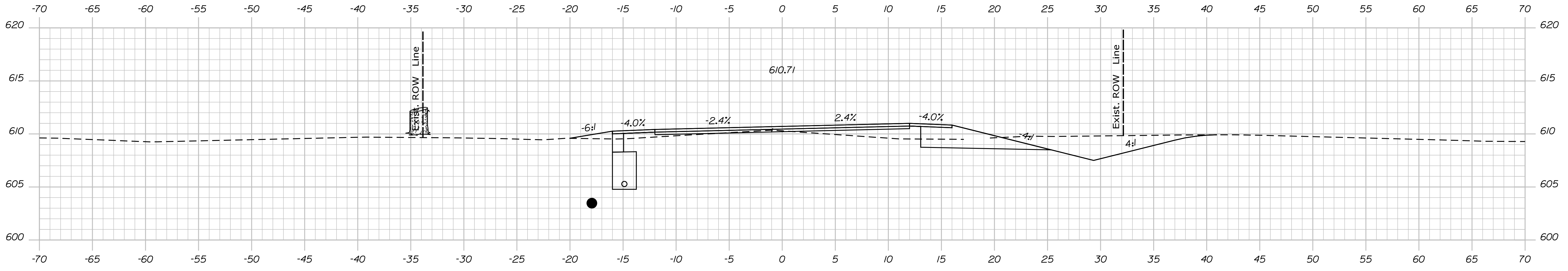

1083+00.00

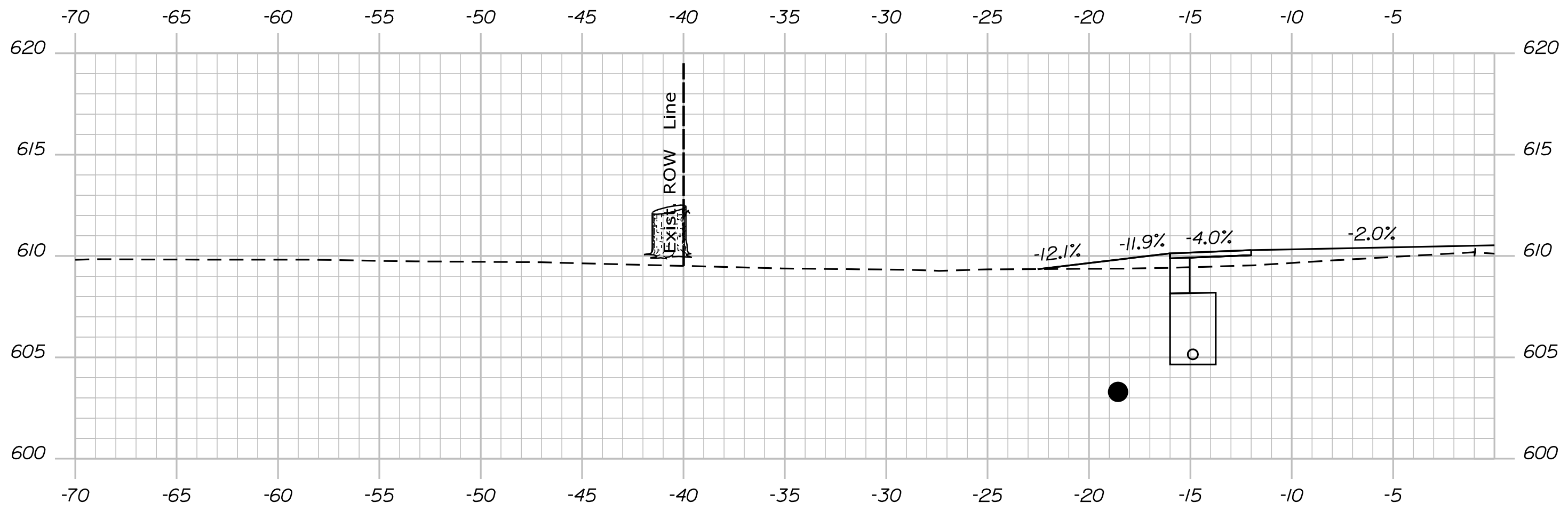

1082+79.00

STATE OF MAINE
DEPARTMENT OF TRANSPORTATION
STP-1824(500)
WIN
18245.00
HIERARCHIC PLANS

SIGNATURE
P.E. NUMBER
DATE

PROJ. MANAGER	DATE
DESIGN DETAILED	
CHECKED/REVIEWED	
DESIGN DETAILED	
DESIGN DETAILED	
REVISIONS 1	
REVISIONS 2	
REVISIONS 3	
REVISIONS 4	
FIELD CHANGES	

KINGFIELD
ROUTE 16\27
CROSS SECTIONS

SHEET NUMBER
Xse
OF 175

Date: \$date\$

Username:

Division: HIGHWAY

Filename: ... \Bentley\ustrn\Xsect.dgn

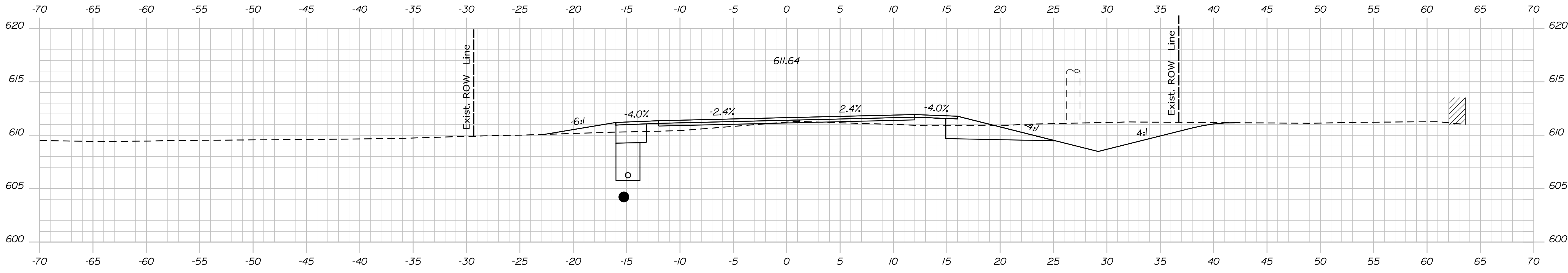

1084+50.00

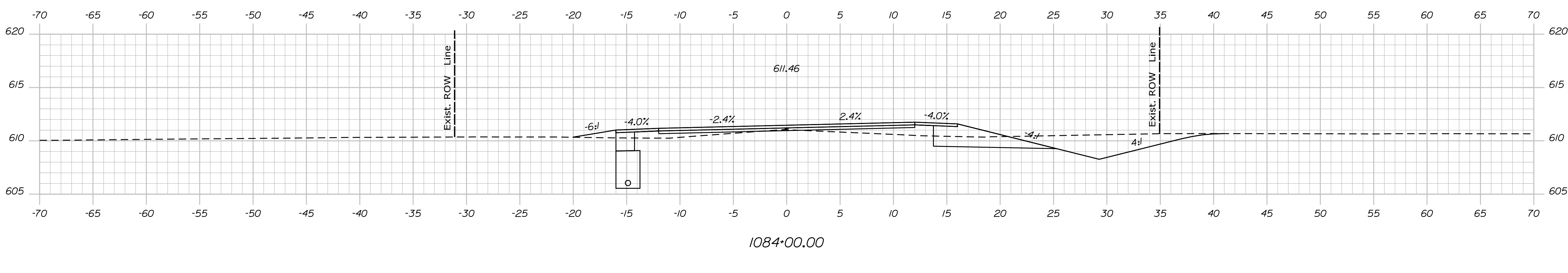

1084+00.00

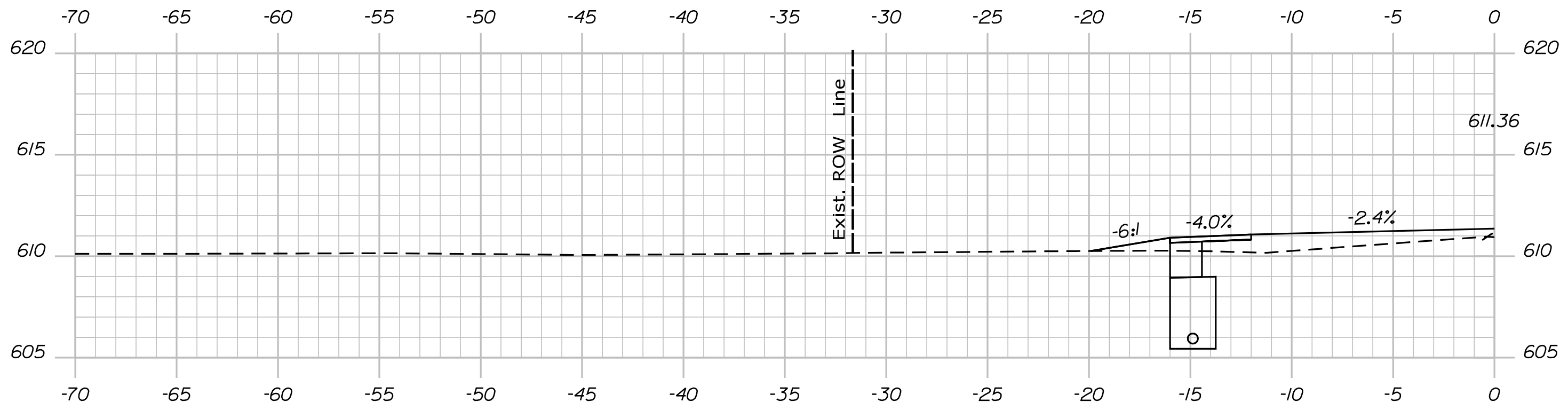

1083+86.00

STATE OF MAINE
DEPARTMENT OF TRANSPORTATION
STP-1824(500)
WIN
18245.00
HIERARCHIC PLANS

SIGNATURE
P.E. NUMBER
DATE

PROJ. MANAGER	DATE
DESIGN DETAILED	
CHECKED/REVIEWED	
DESIGN DETAILED	
DESIGN DETAILED	
REVISIONS 1	
REVISIONS 2	
REVISIONS 3	
REVISIONS 4	
FIELD CHANGES	

KINGFIELD
ROUTE 16\27
CROSS SECTIONS

SHEET NUMBER
Xse
OF 175

Date: \$date\$

Username:

Division: HIGHWAY

Filename: ... \Bentley\ustrn\Xsect.dgn

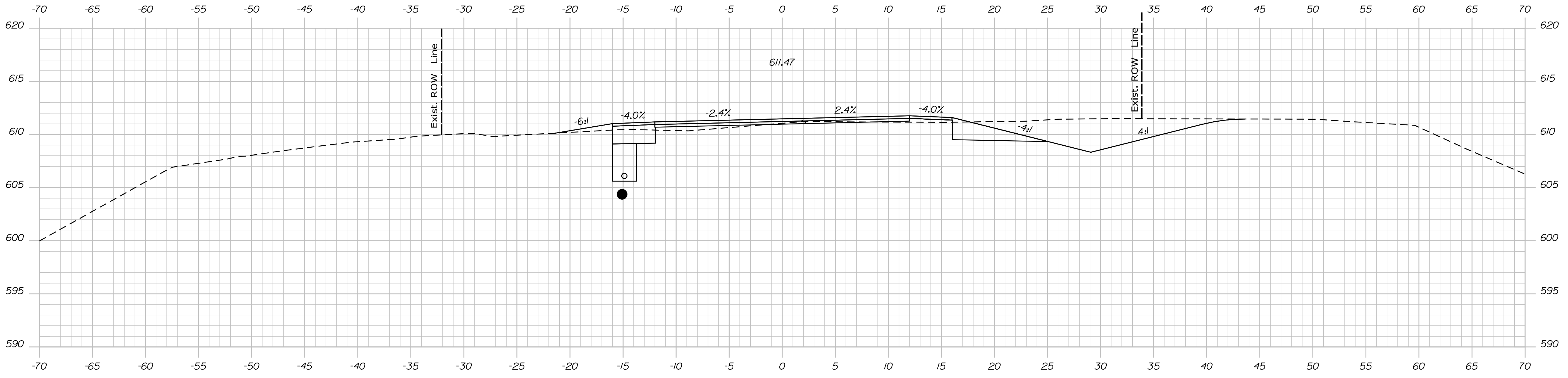

1085+50.00

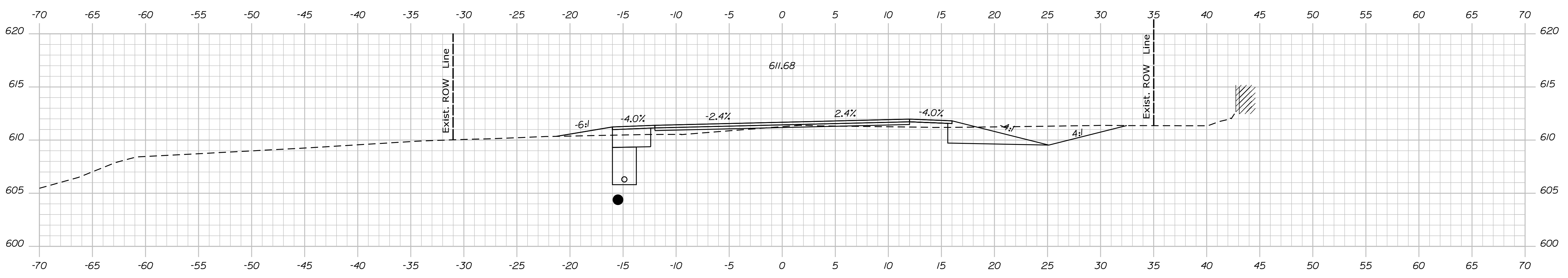

1085+00.00

STATE OF MAINE
 DEPARTMENT OF TRANSPORTATION
 STP-1824(500)
 WIN
 18245.00
 HIGHWAY PLANS

SIGNATURE
 P.E. NUMBER
 DATE

PROJ. MANAGER	DATE
DESIGN DETAILED	
CHECKED/REVIEWED	
DESIGN DETAILED	
DESIGN DETAILED	
REVISIONS 1	
REVISIONS 2	
REVISIONS 3	
REVISIONS 4	
FIELD CHANGES	

KINGFIELD
 ROUTE 16\27
 CROSS SECTIONS

SHEET NUMBER
Xse
 OF 175

Date: \$date\$

Username:

Division: HIGHWAY

Filename: ... \Bentley\ustrn\Xsect.dgn

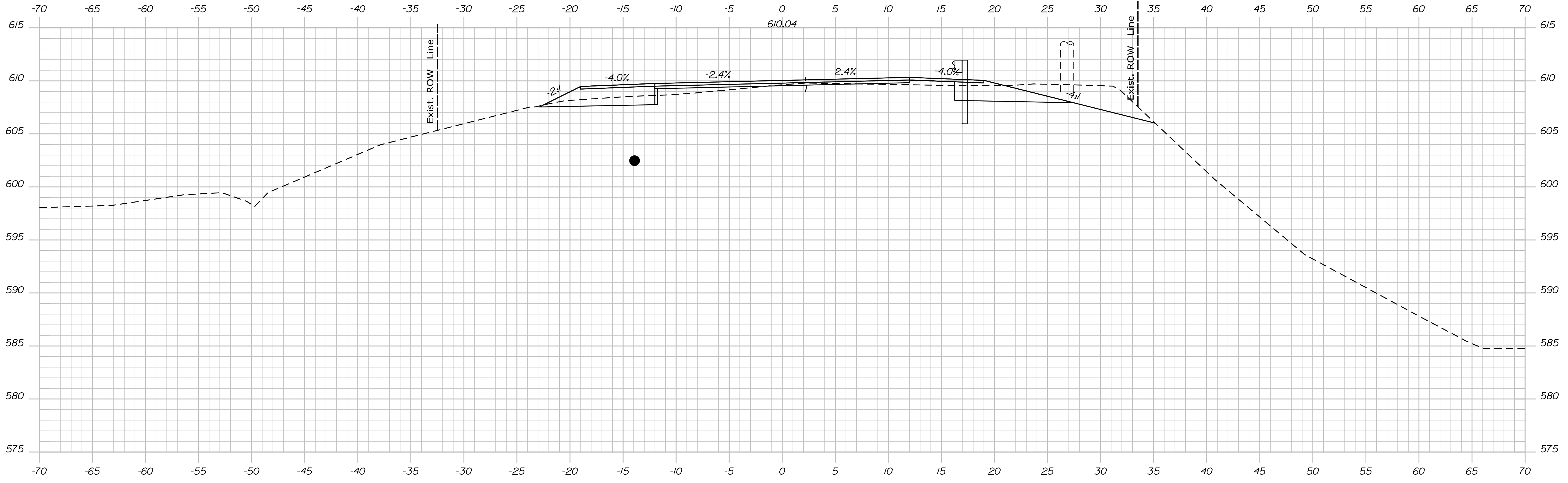

1086+50.00

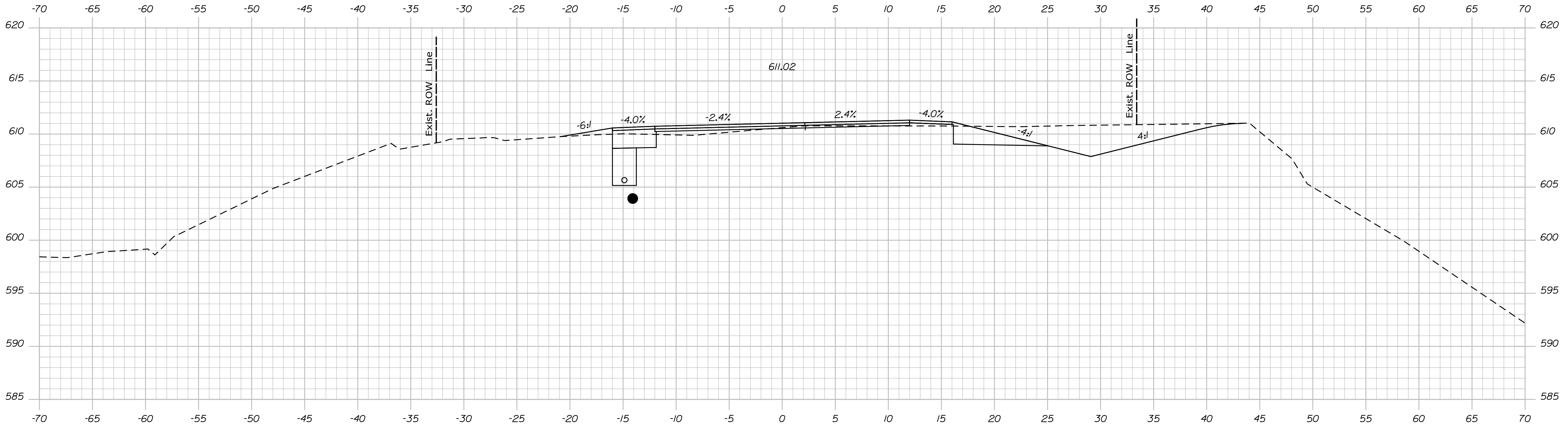

1086+00.00

STATE OF MAINE
 DEPARTMENT OF TRANSPORTATION
STP-1824(500)
 WIN
 18245.00
 HIGHWAY PLANS

SIGNATURE
 P.E. NUMBER
 DATE

PROJ. MANAGER	DATE
DESIGN DETAILER <td> </td>	
CHECKED/REVIEWED <td> </td>	
DESIGN DETAILER <td> </td>	
DESIGN DETAILER <td> </td>	
REVISIONS 1 <td> </td>	
REVISIONS 2 <td> </td>	
REVISIONS 3 <td> </td>	
REVISIONS 4 <td> </td>	
FIELD CHANGES <td> </td>	

KINGFIELD
 ROUTE 16\27
 CROSS SECTIONS

SHEET NUMBER
Xse
 OF 175

Date: \$date\$

Username:

Division: HIGHWAY

Filename: ... \Bentley\ustrn\Xsect.dgn

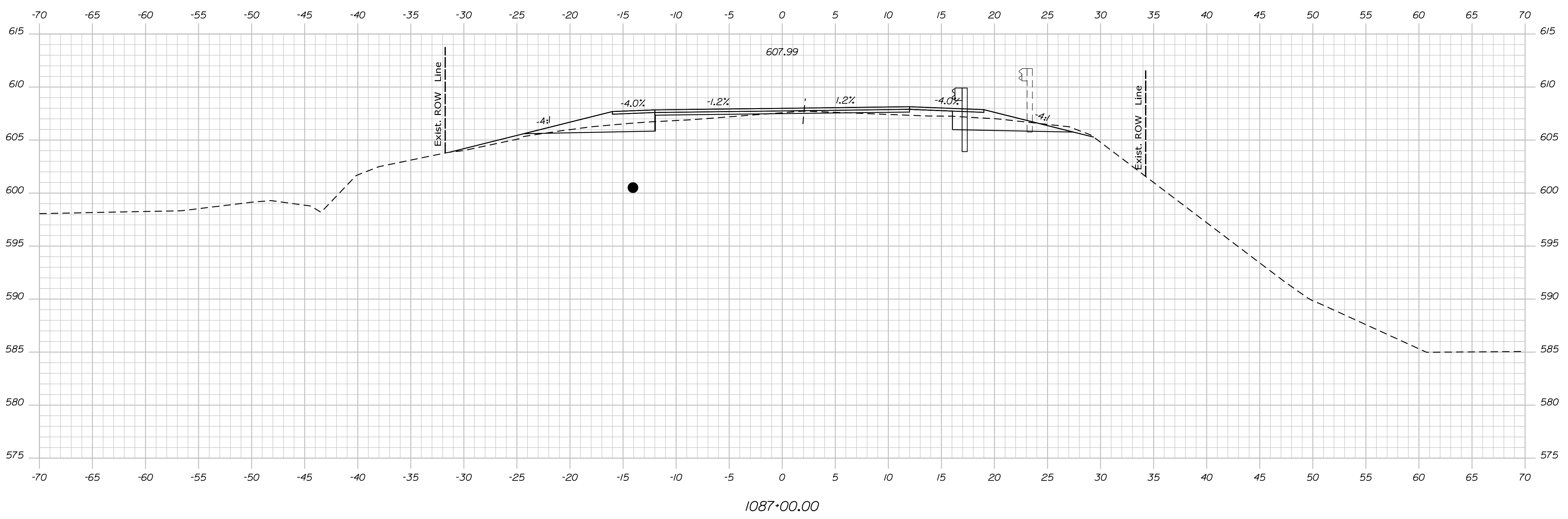
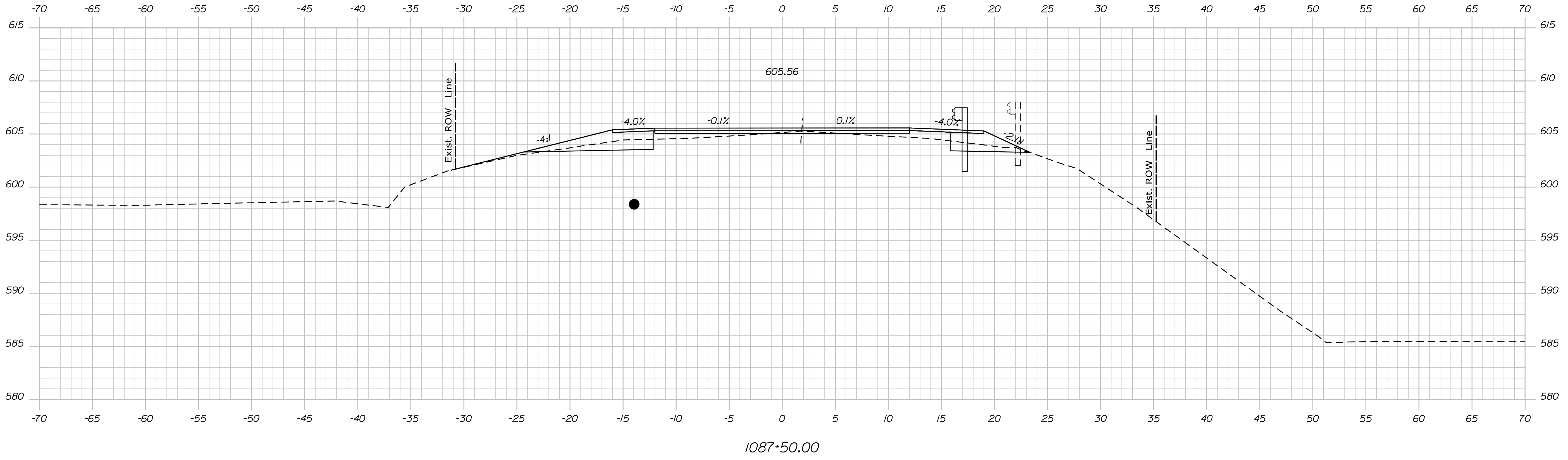

STATE OF MAINE
 DEPARTMENT OF TRANSPORTATION
 STP-1824(500)
 WIN
 18245.00
 HIGHWAY PLANS

SIGNATURE	DATE
P.E. NUMBER	DATE

PROJ. MANAGER	DATE
DESIGN-DETAILED	
CHECKED-REVIEWED	
DESIGN-DETAILED	
DESIGN-DETAILED	
REVISIONS 1	
REVISIONS 2	
REVISIONS 3	
REVISIONS 4	
FIELD CHANGES	

KINGFIELD
 ROUTE 16\27
 CROSS SECTIONS

SHEET NUMBER
 Xse
 OF 175

Date: \$date\$

Username:

Division: HIGHWAY

Filename: ... \Bentley\ustrn\Xsect.dgn

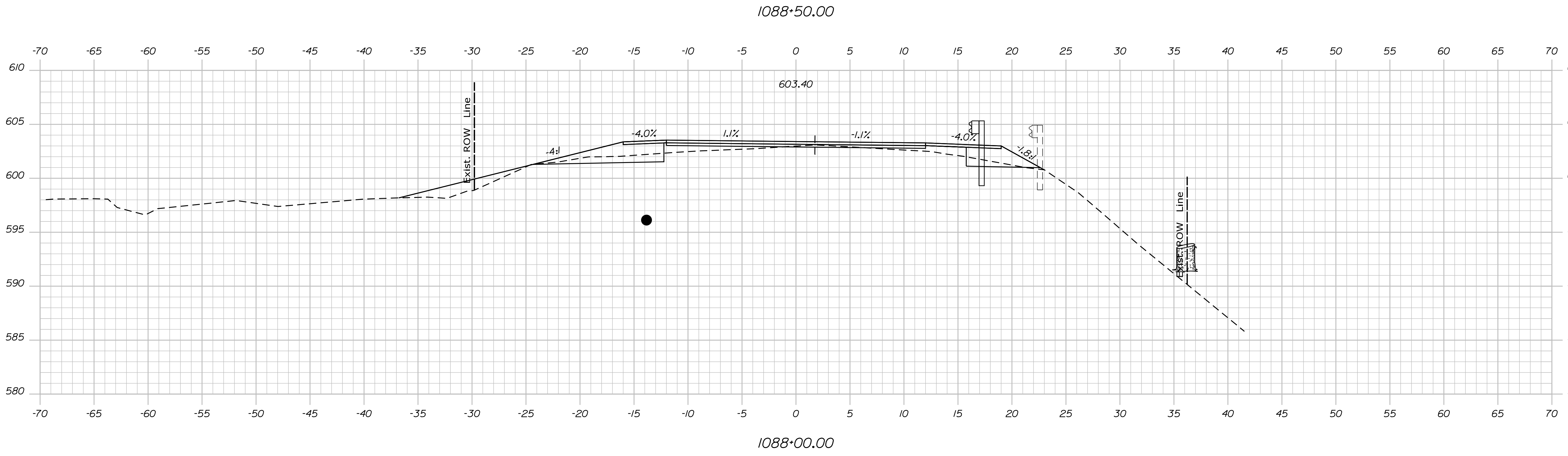
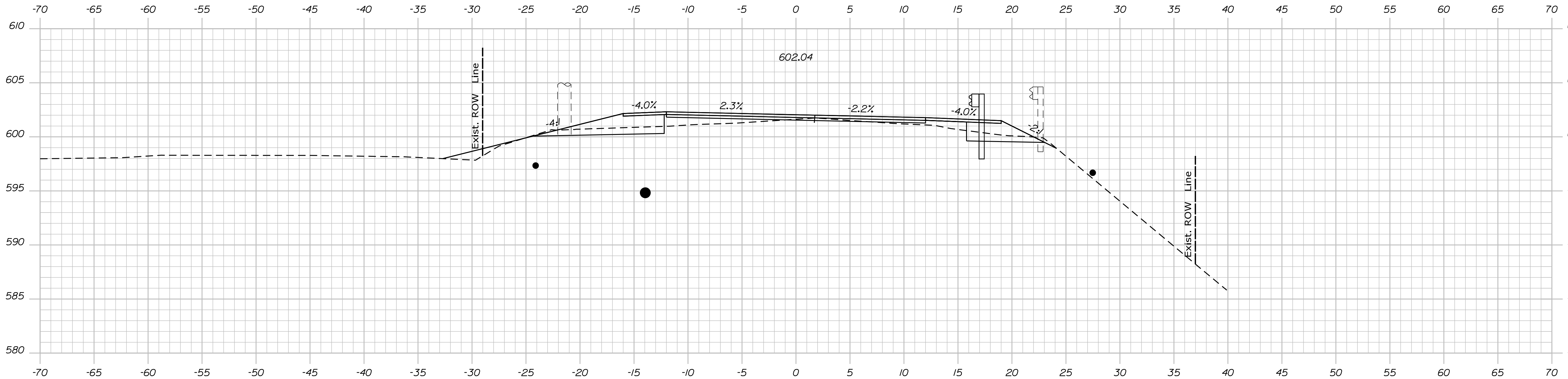

STATE OF MAINE
 DEPARTMENT OF TRANSPORTATION
STP-1824(500)
 WIN
 18245.00
 HIERARCHIC PLANS

PROJ. MANAGER	DATE
DESIGN DETAILED	SIGNATURE
CHECKED/REVIEWED	P.E. NUMBER
DESIGN DETAILER	DATE
DESIGN DETAILER	
REVISIONS 1	
REVISIONS 2	
REVISIONS 3	
REVISIONS 4	
FIELD CHANGES	

KINGFIELD
 ROUTE 16\27
 CROSS SECTIONS

SHEET NUMBER
Xse
 OF 175

Date: \$date\$

Username:

Division: HIGHWAY

Filename: ... \Bentley\ustrn\Xsect.dgn

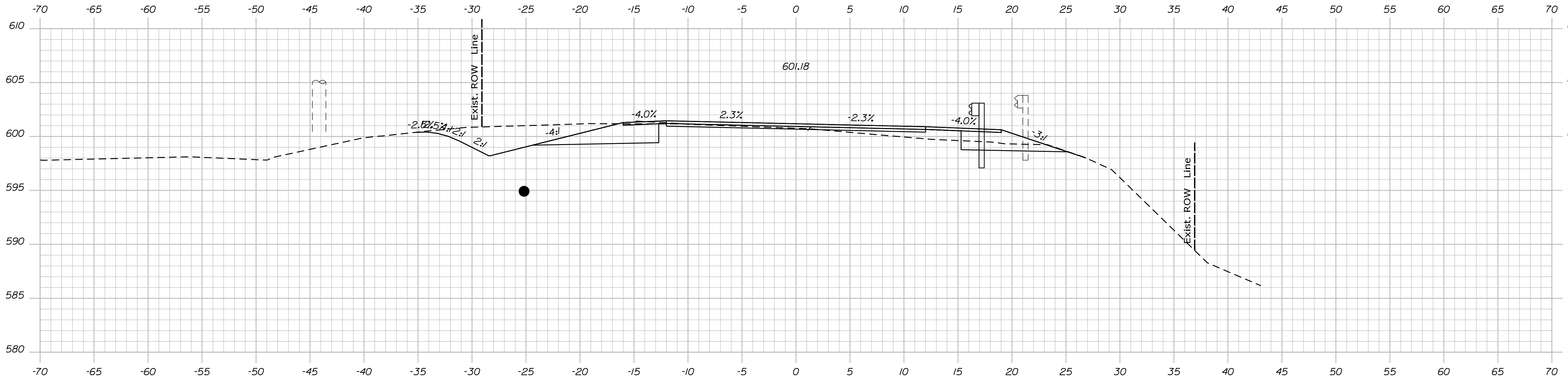

1089+50.00

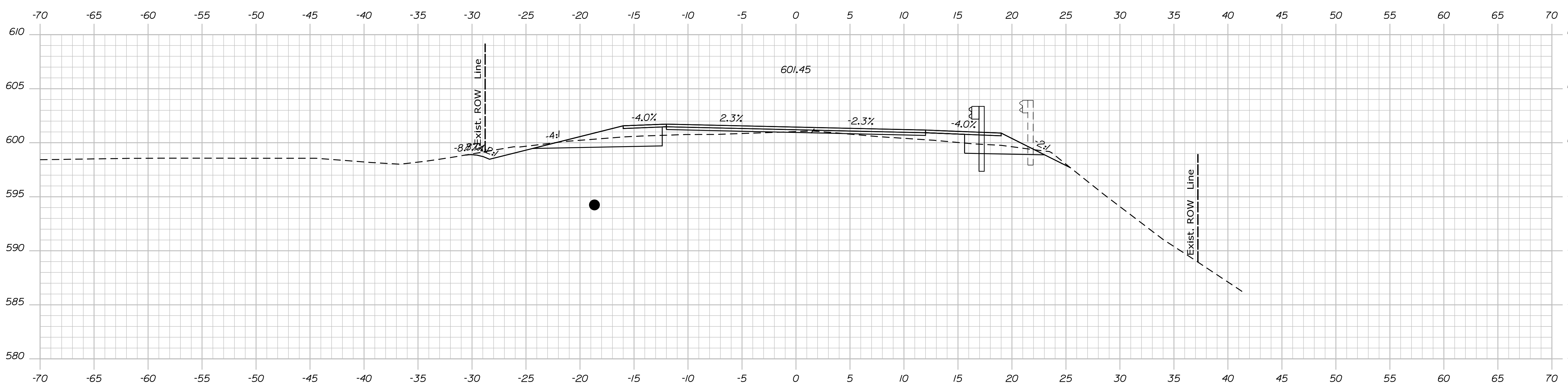

1089+00.00

STATE OF MAINE
DEPARTMENT OF TRANSPORTATION
STP-1824(500)
WIN
18245.00
HIERARCHIC PLANS

SIGNATURE
P.E. NUMBER
DATE

PROJ. MANAGER	DATE
DESIGN DETAILED	
CHECKED/REVIEWED	
DESIGN DETAILED	
DESIGN DETAILED	
REVISIONS 1	
REVISIONS 2	
REVISIONS 3	
REVISIONS 4	
FIELD CHANGES	

KINGFIELD
ROUTE 16\27
CROSS SECTIONS

SHEET NUMBER
Xse
OF 175

Date: \$date\$

Username:

Division: HIGHWAY

Filename: ... \Bentley\ustrn\Xsect.dgn

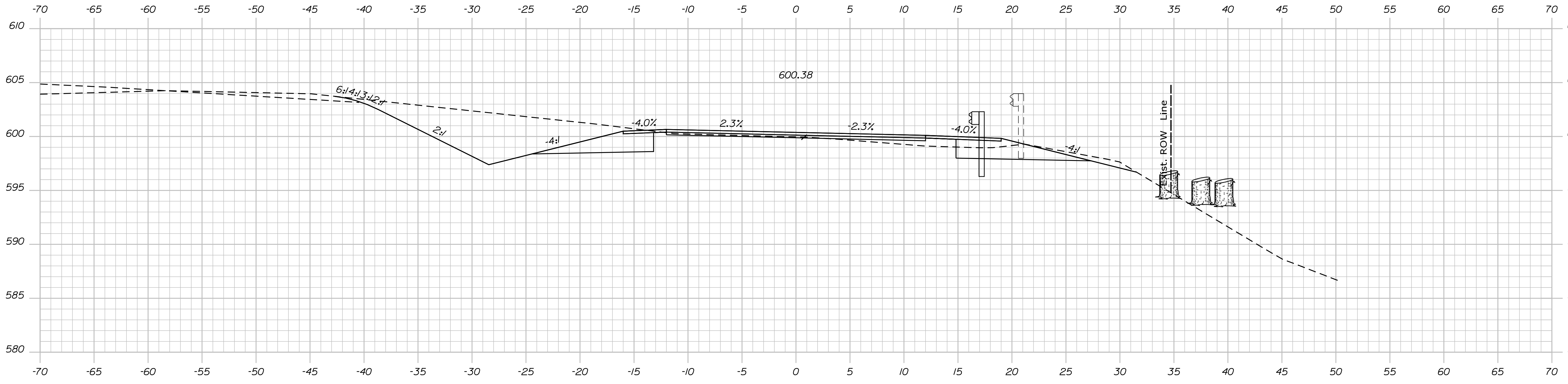

1090+50.00

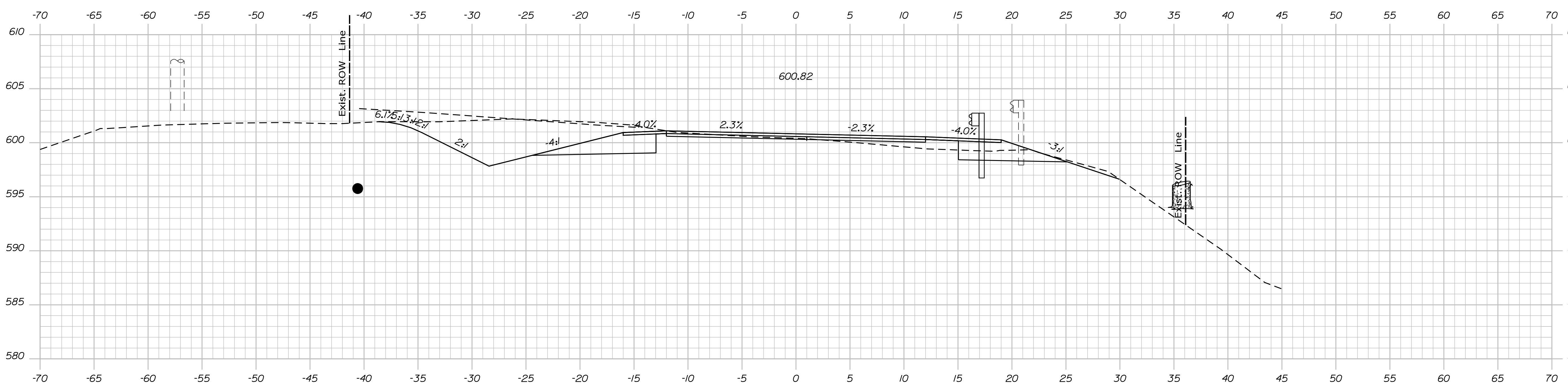

1090+00.00

STATE OF MAINE
DEPARTMENT OF TRANSPORTATION
STP-1824(500)
WIN
18245.00
HIERARCHIC PLANS

PROJ. MANAGER	DATE
DESIGN DETAILED	
CHECKED/REVISED	
DESIGN DETAILED	
DESIGN DETAILED	
REVISIONS 1	
REVISIONS 2	
REVISIONS 3	
REVISIONS 4	
FIELD CHANGES	

KINGFIELD
ROUTE 16\27
CROSS SECTIONS

SHEET NUMBER
Xse
OF 175

Date: \$date\$

Username:

Division: HIGHWAY

Filename: ... \Bentley\ustrn\Xsect.dgn

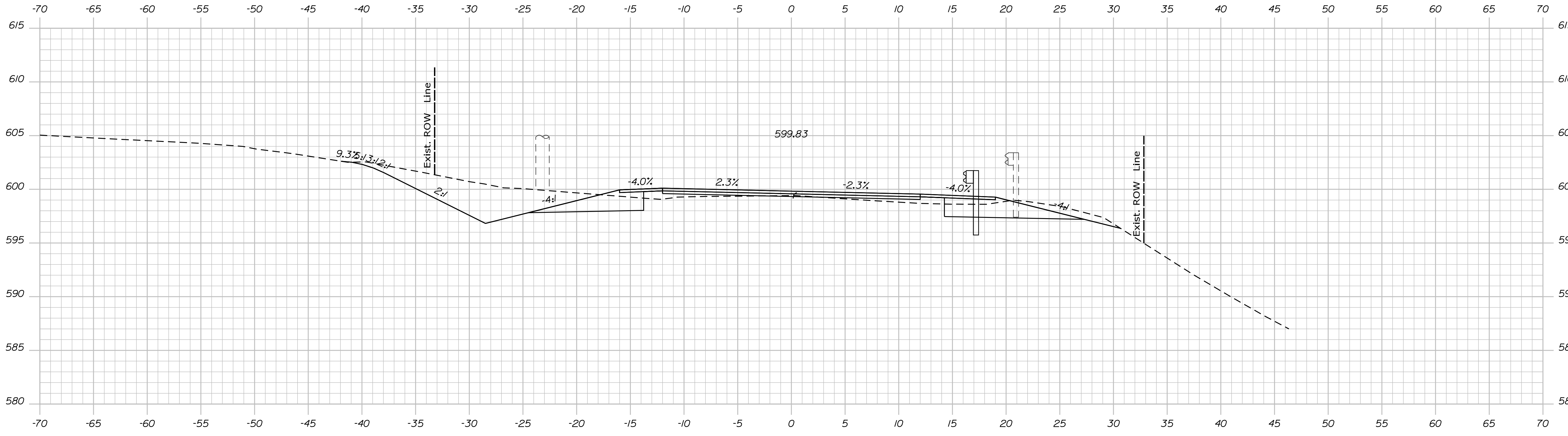
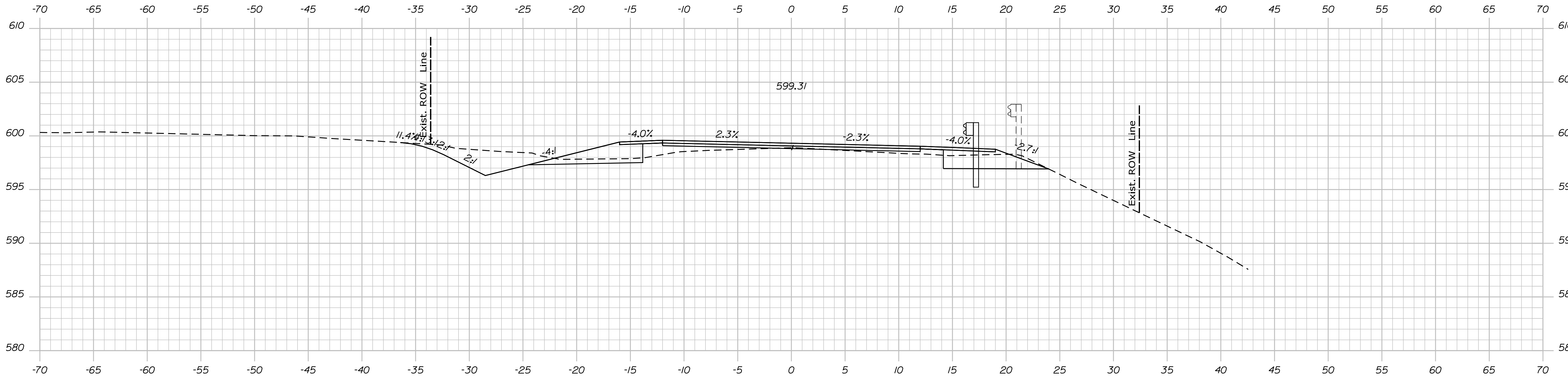

STATE OF MAINE
DEPARTMENT OF TRANSPORTATION
STP-1824(500)
WIN
18245.00
HIERARCHIC PLANS

SIGNATURE	P.E. NUMBER	DATE

PROJ. MANAGER	DATE
DESIGN DETAILED	
CHECKED/REVIEWED	
DESIGN DETAILED	
DESIGN DETAILED	
REVISIONS 1	
REVISIONS 2	
REVISIONS 3	
REVISIONS 4	
FIELD CHANGES	

KINGFIELD
ROUTE 16\27
CROSS SECTIONS

SHEET NUMBER
Xse
OF 175

Date: \$date\$

Username:

Division: HIGHWAY

Filename: ... \Bentley\ustrn\Xsect.dgn

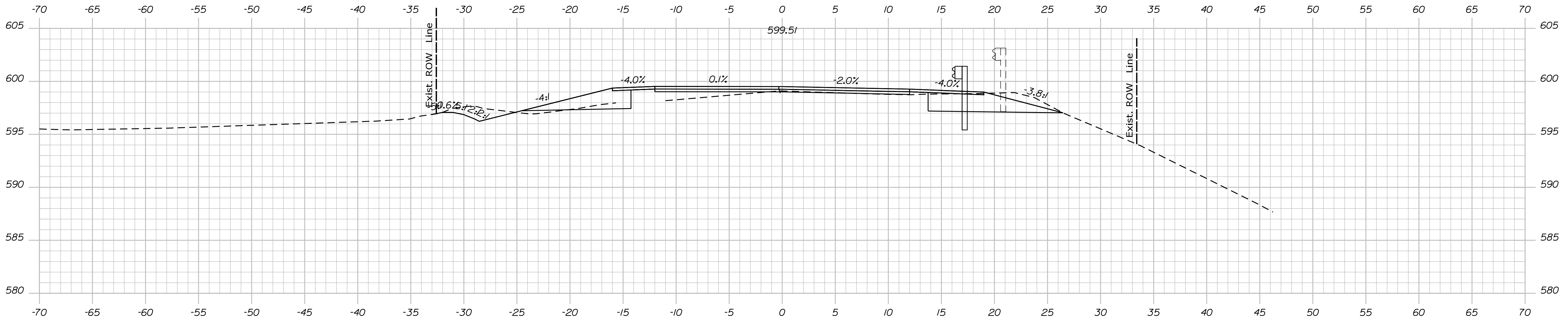

1093+00.00

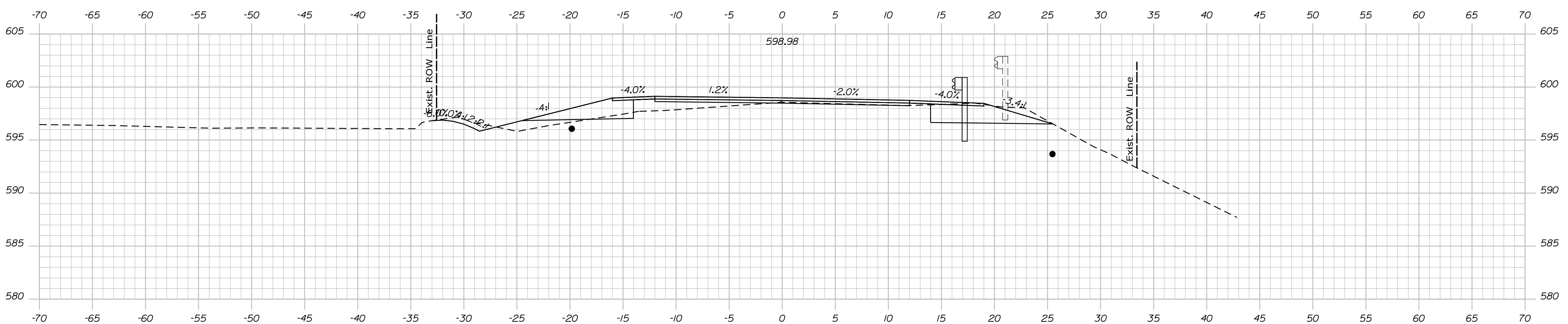

1092+50.00

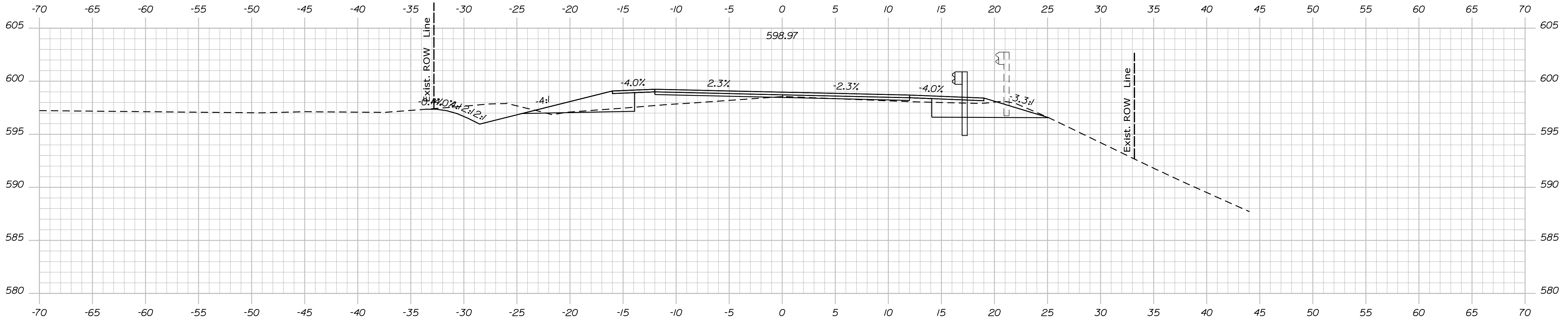

1092+00.00

STATE OF MAINE
DEPARTMENT OF TRANSPORTATION
STP-1824(500)
WIN
18245.00
HIERARCHIC PLANS

PROJ. MANAGER	DATE	BY	DATE
DESIGN DETAILED			
CHECKED/REVISED			
DESIGN DETAILED			
DESIGN DETAILED			
REVISIONS 1			
REVISIONS 2			
REVISIONS 3			
REVISIONS 4			
FIELD CHANGES			

KINGFIELD
ROUTE 16\27
CROSS SECTIONS

SHEET NUMBER
Xse
OF 175

Sta. 1092+00.00 to Sta. 1093+00.00

Date: \$date\$

Username:

Division: HIGHWAY

Filename: ... \Bentley\ustrn\Xsect.dgn

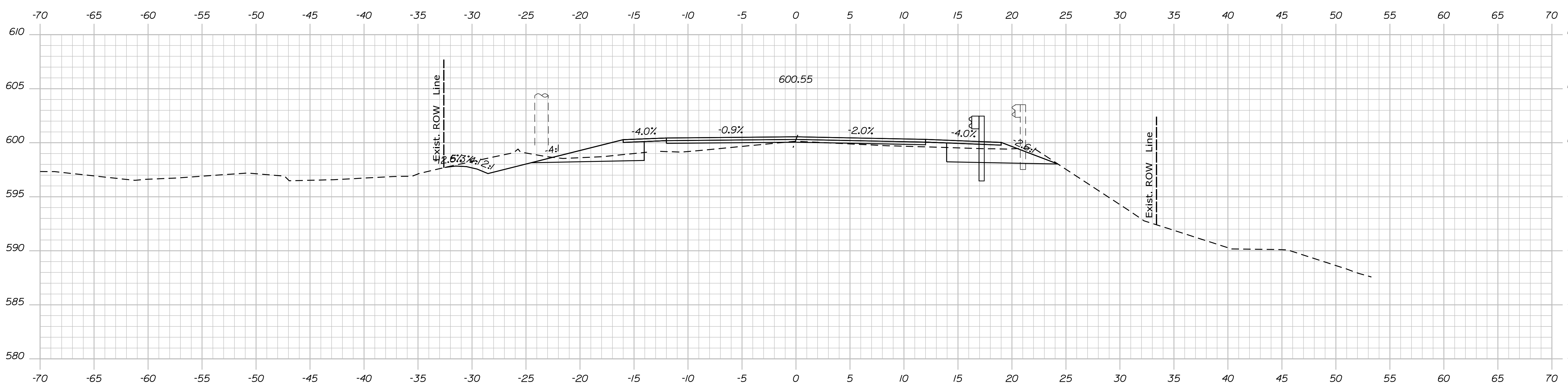
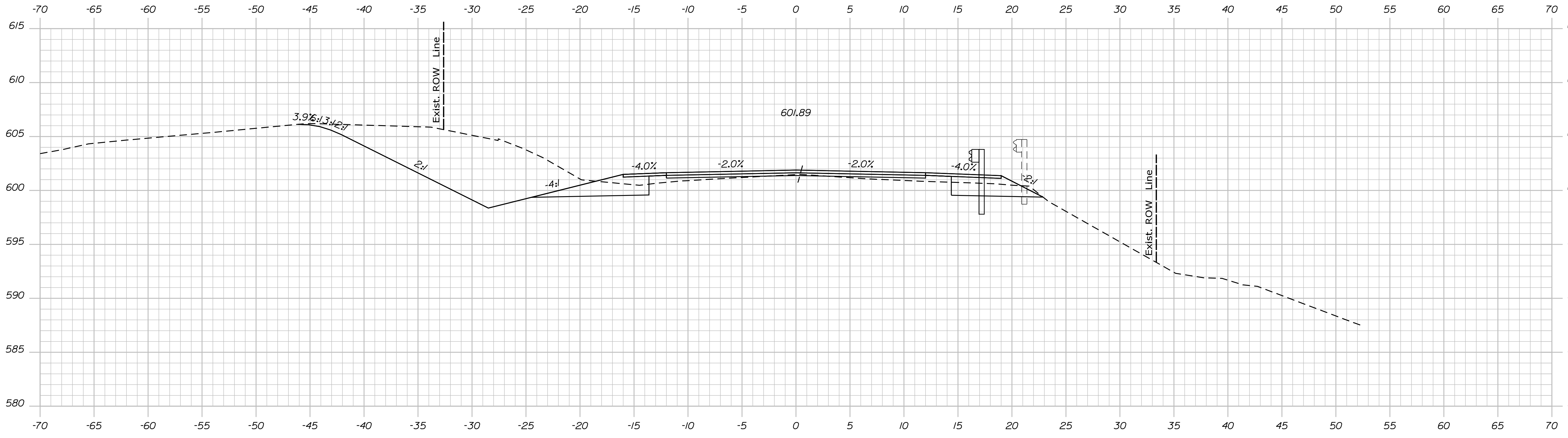

STATE OF MAINE
DEPARTMENT OF TRANSPORTATION
STP-1824(500)
WIN
18245.00
HIERARCHIC PLANS

SIGNATURE
P.E. NUMBER
DATE

PROJ. MANAGER	DATE
DESIGN DETAILED	
CHECKED/REVISED	
DESIGN DETAILED	
DESIGN DETAILED	
REVISIONS 1	
REVISIONS 2	
REVISIONS 3	
REVISIONS 4	
FIELD CHANGES	

KINGFIELD
ROUTE 16\27
CROSS SECTIONS

SHEET NUMBER
Xse
OF 175

Date: \$date\$

Username:

Division: HIGHWAY

Filename: ... \Bentley\ustrn\Xsect.dgn

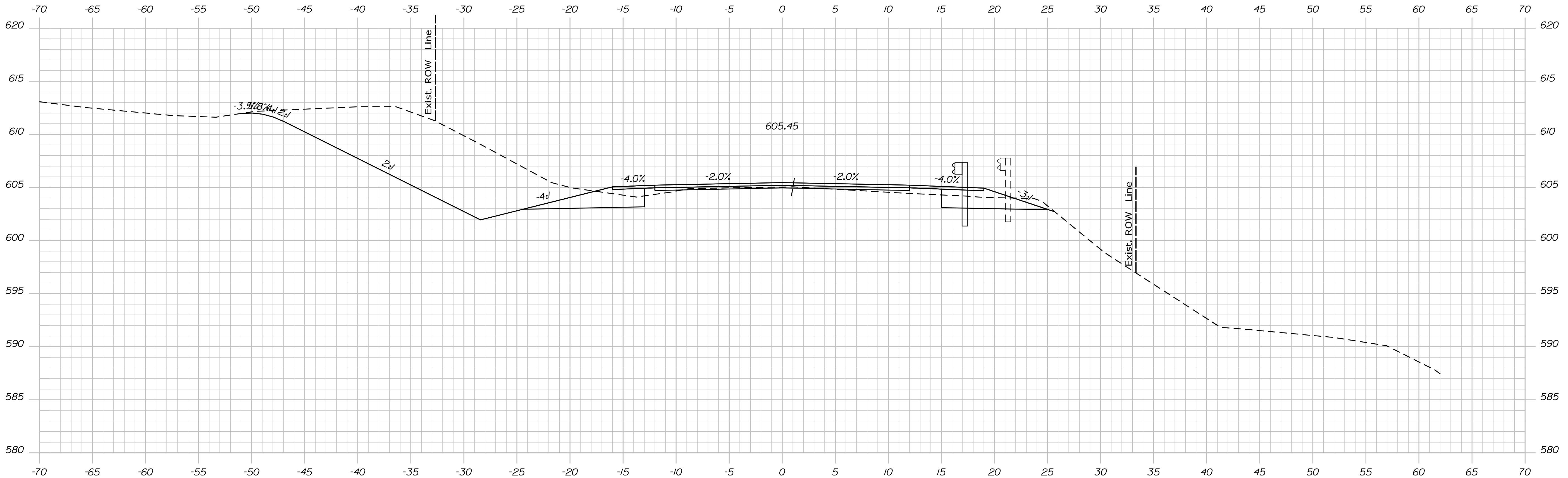

1095+00.00

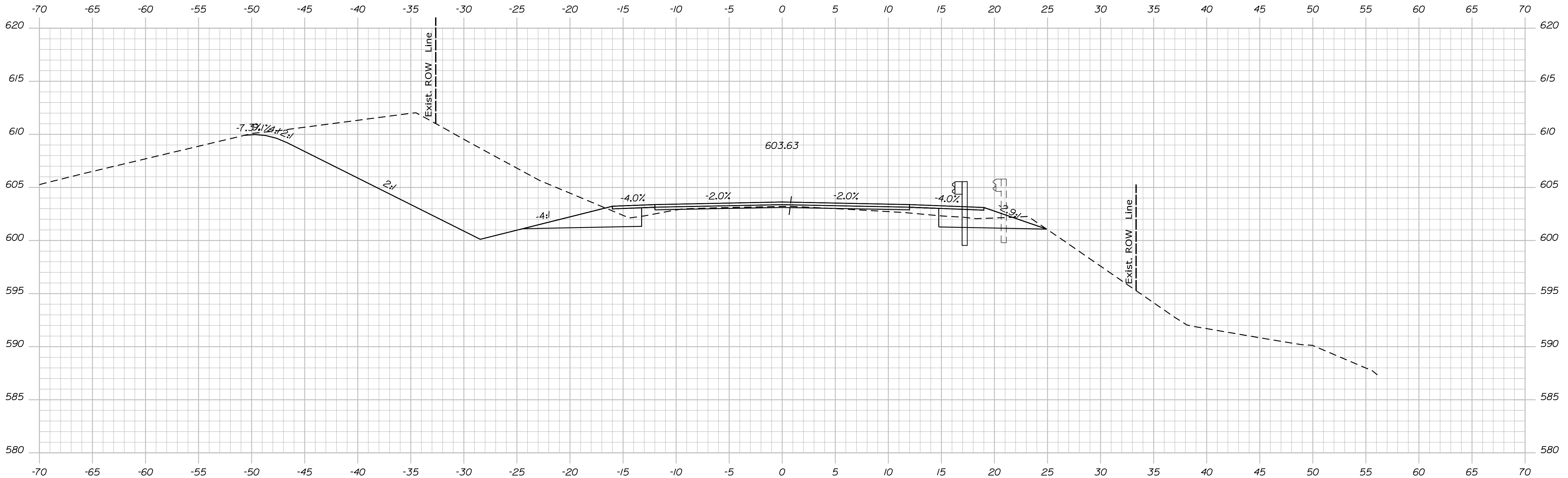

1094+50.00

STATE OF MAINE
 DEPARTMENT OF TRANSPORTATION
 STP-1824(500)
 WIN
 18245.00
 HIGHWAY PLANS

SIGNATURE
 P.E. NUMBER
 DATE

PROJ. MANAGER	DATE
DESIGN DETAILED	
CHECKED/REVIEWED	
DESIGN DETAILED	
DESIGN DETAILED	
REVISIONS 1	
REVISIONS 2	
REVISIONS 3	
REVISIONS 4	
FIELD CHANGES	

KINGFIELD
 ROUTE 16\27
 CROSS SECTIONS

SHEET NUMBER
Xse
 OF 175

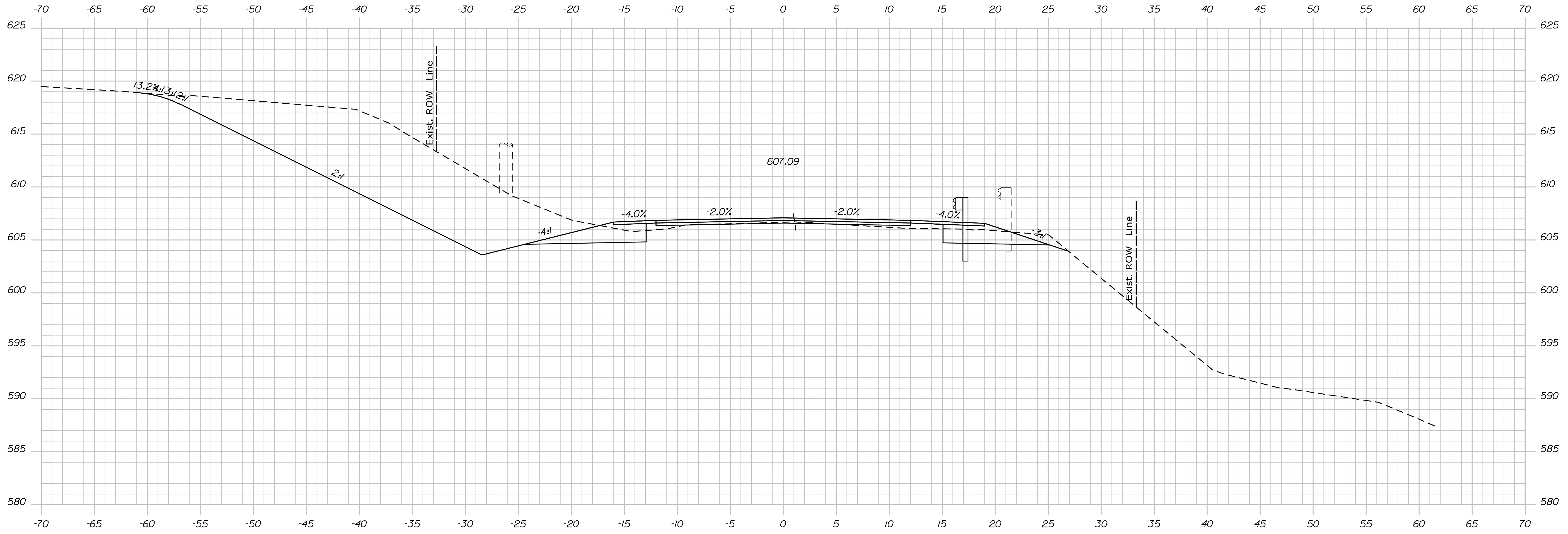

1095+50.00

Sta. 1095+50.00 to Sta. 1095+50.00

STATE OF MAINE
 DEPARTMENT OF TRANSPORTATION
STP-1824(500)

WIN
 18245.00
 HIERARCHIC PLANS

PROJ. MANAGER	BY	DATE
DESIGN DETAILED		
CHECKED/REVIEWED		
DESIGN DETAILED		
DESIGN DETAILED		
REVISIONS 1		
REVISIONS 2		
REVISIONS 3		
REVISIONS 4		
FIELD CHANGES		

**KINGFIELD
 ROUTE 16\27**
CROSS SECTIONS

SHEET NUMBER
Xse
 OF 175

Date: \$date\$

Username:

Division: HIGHWAY

Filename: ... \Bentley\ustrn\Xsect.dgn

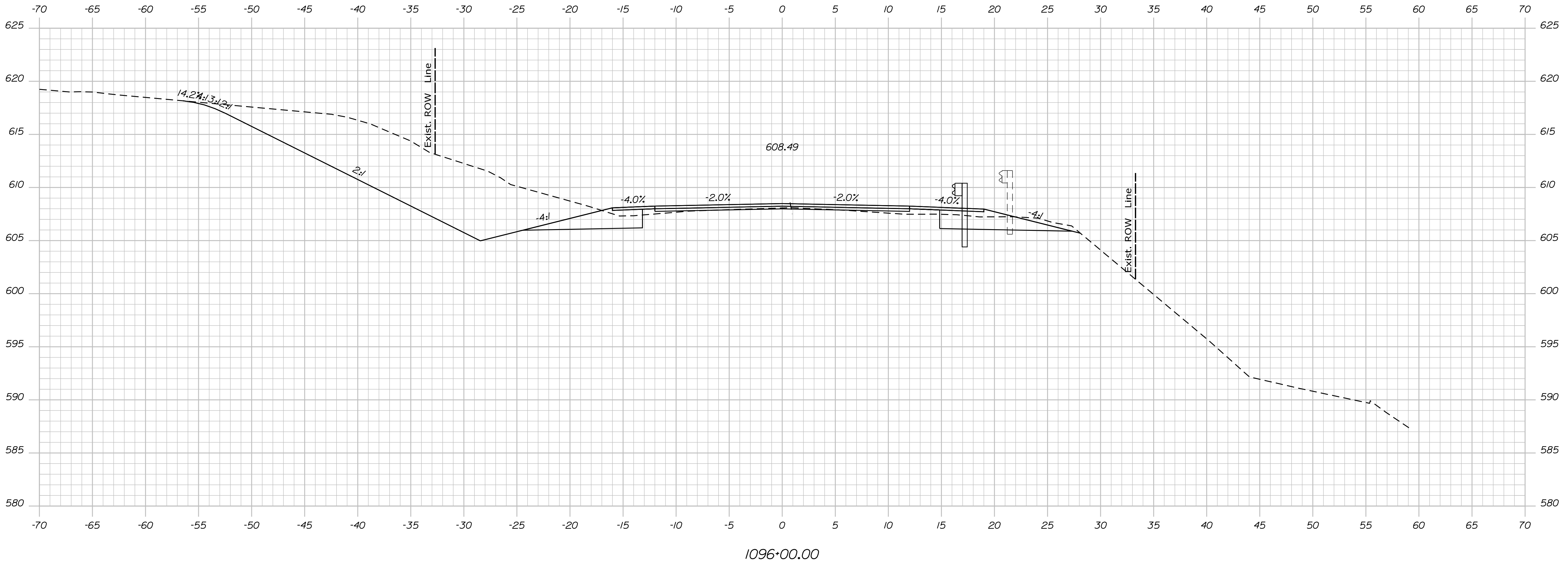
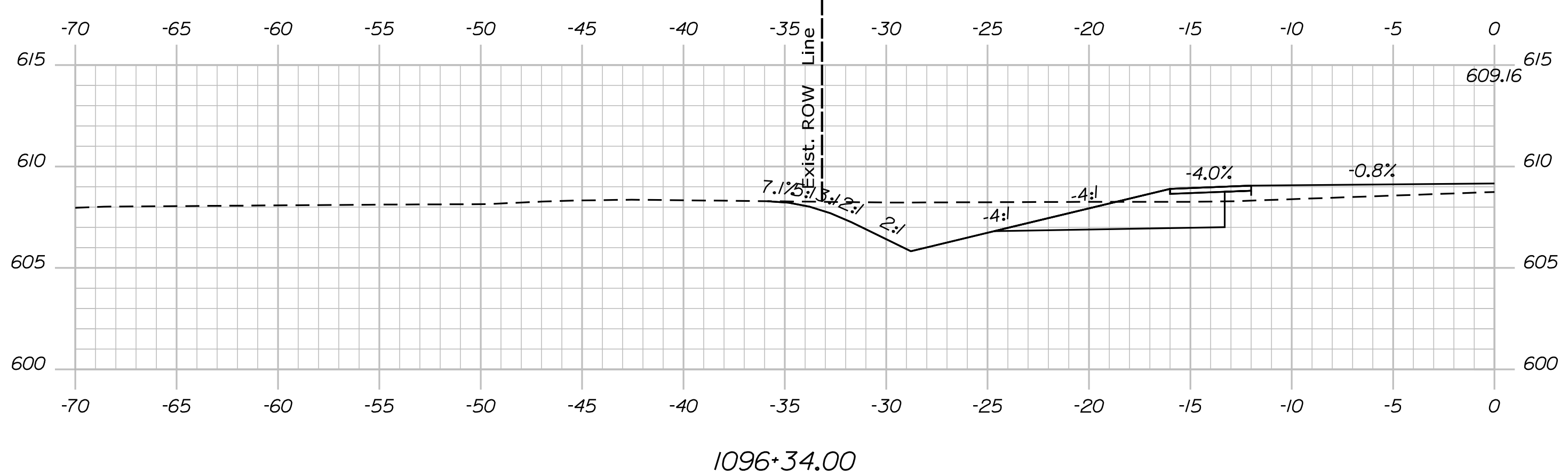

STATE OF MAINE
DEPARTMENT OF TRANSPORTATION
STP-1824(500)
WIN
18245.00
HIERARCHIC PLANS

SIGNATURE
P.E. NUMBER
DATE

PROJ. MANAGER	DATE
DESIGN DETAILED	
CHECKED/REVISED	
DESIGN DETAILED	
DESIGN DETAILED	
REVISIONS 1	
REVISIONS 2	
REVISIONS 3	
REVISIONS 4	
FIELD CHANGES	

KINGFIELD
ROUTE 16\27
CROSS SECTIONS

SHEET NUMBER
Xse
OF 175

Date: \$date\$

Username:

Division: HIGHWAY

Filename: ... \Bentley\ustrn\Xsect.dgn

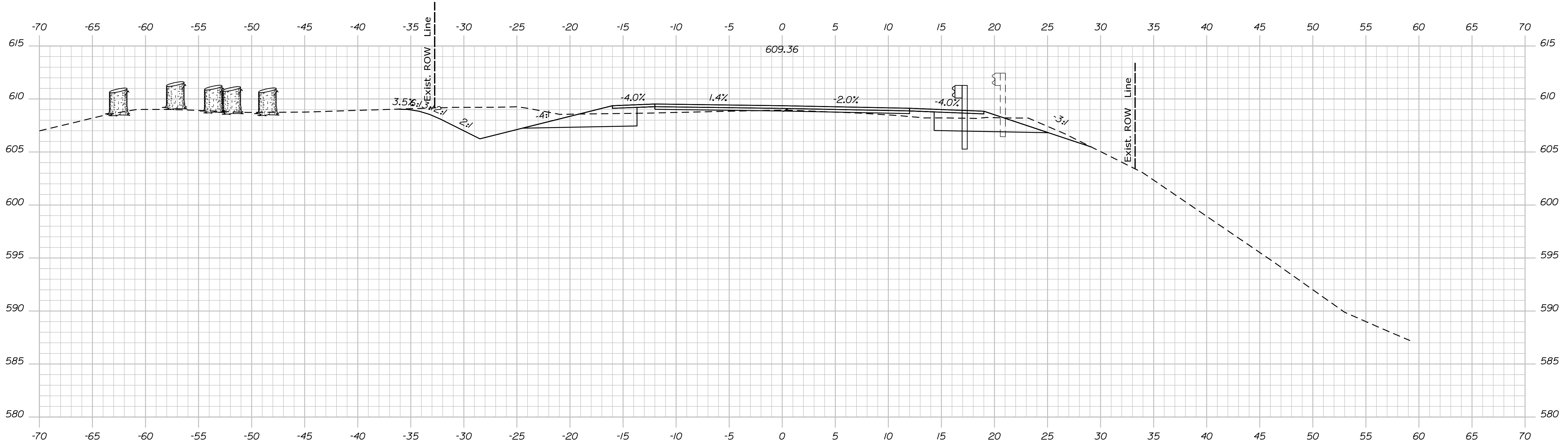

1097+00.00

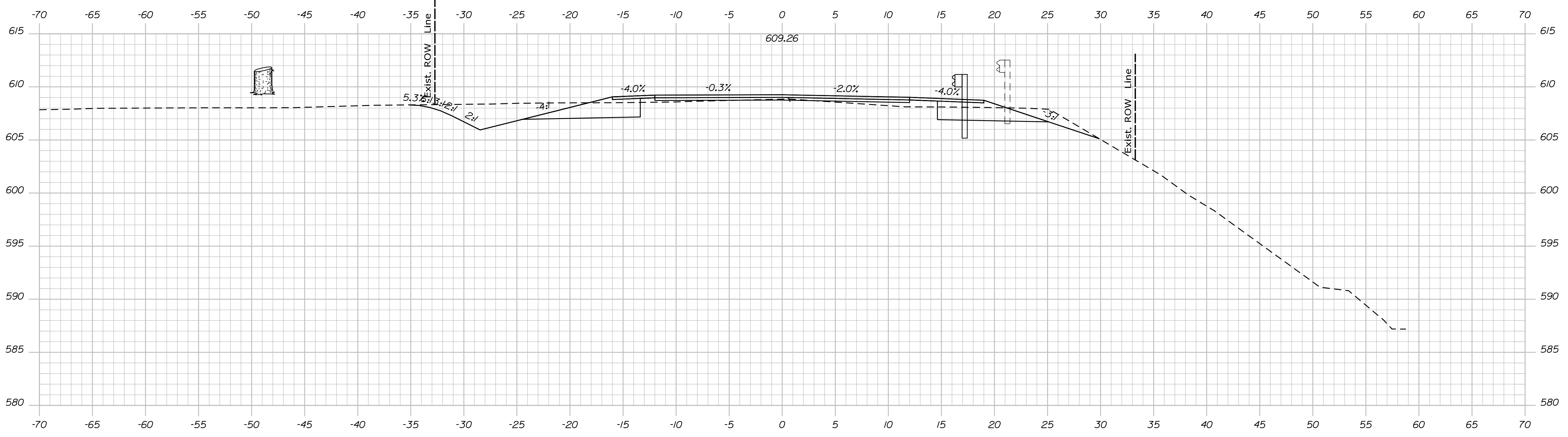

1096+50.00

STATE OF MAINE
DEPARTMENT OF TRANSPORTATION
STP-1824(500)
WIN
18245.00
HIERARCHIC PLANS

SIGNATURE
P.E. NUMBER
DATE

PROJ. MANAGER	DATE
DESIGN DETAILED	
CHECKED/REVIEWED	
DESIGN DETAILED	
DESIGN DETAILED	
REVISIONS 1	
REVISIONS 2	
REVISIONS 3	
REVISIONS 4	
FIELD CHANGES	

KINGFIELD
ROUTE 16\27
CROSS SECTIONS

SHEET NUMBER
Xse
OF 175

Date: \$date\$

Username:

Division: HIGHWAY

Filename: ... \Bentley\ustr\Xsect.dgn

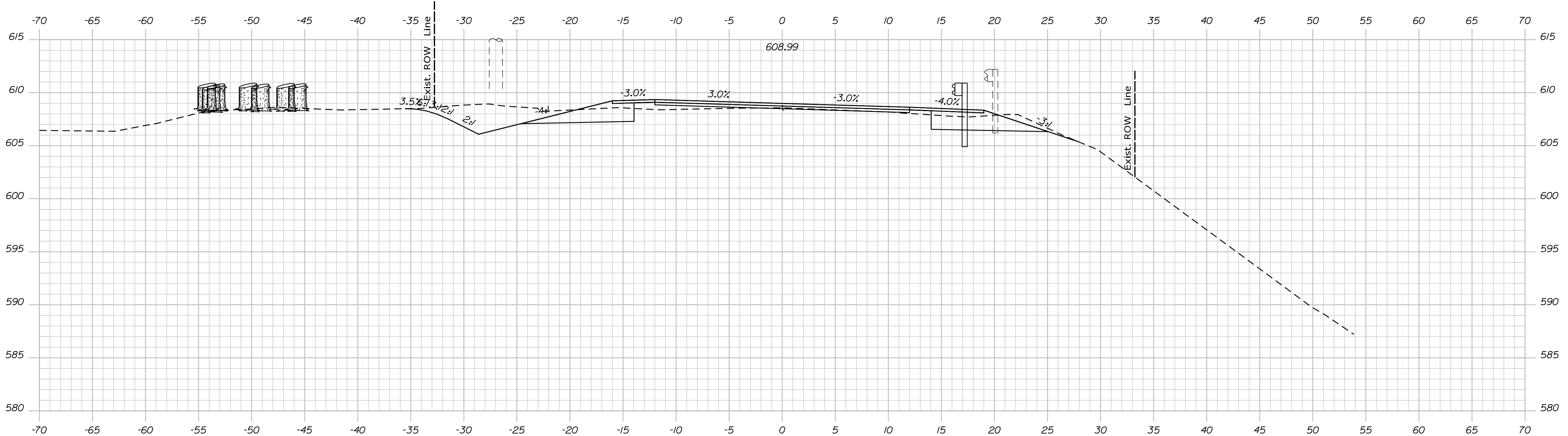
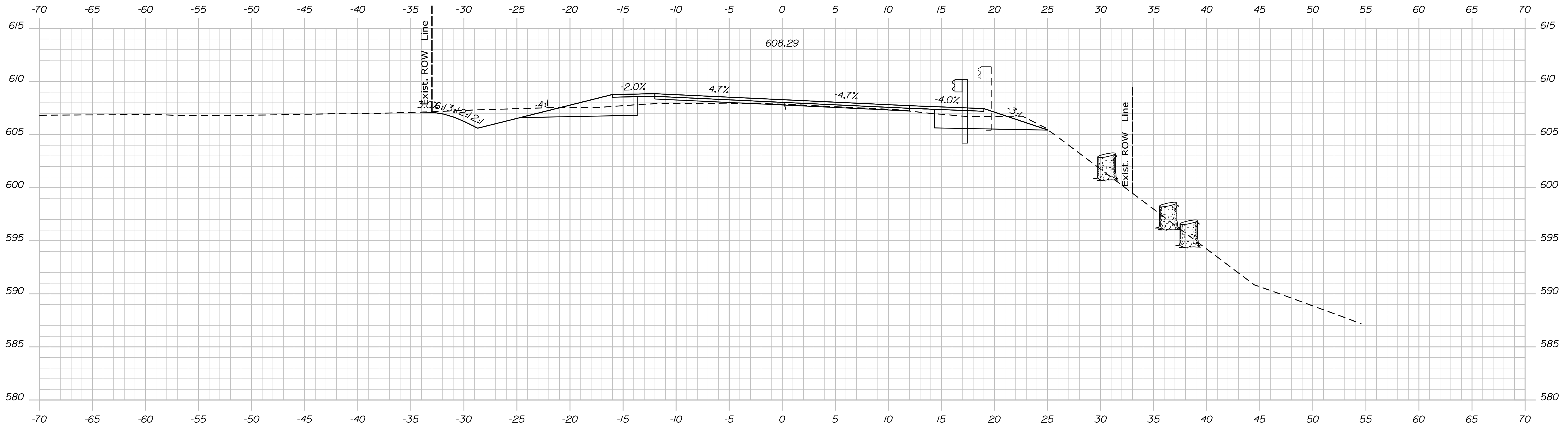

STATE OF MAINE
DEPARTMENT OF TRANSPORTATION
STP-1824(500)
WIN
18245.00
HIERARCHIC PLANS

SIGNATURE
P.E. NUMBER
DATE

PROJ. MANAGER	DATE
DESIGN DETAILED	
CHECKED/REVIEWED	
DESIGN DETAILED	
DESIGN DETAILED	
REVISIONS 1	
REVISIONS 2	
REVISIONS 3	
REVISIONS 4	
FIELD CHANGES	

KINGFIELD
ROUTE 16\27
CROSS SECTIONS

SHEET NUMBER
Xse
OF 175

Date: \$date\$

Username:

Division: HIGHWAY

Filename: ... \Bentley\ustrn\Xsect.dgn

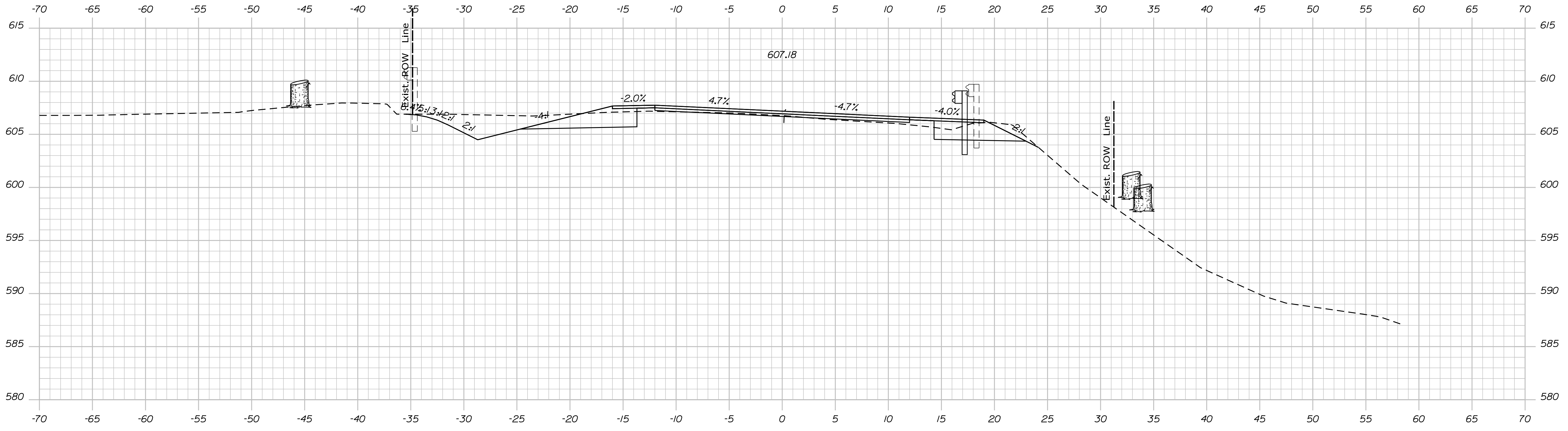

1098+50.00

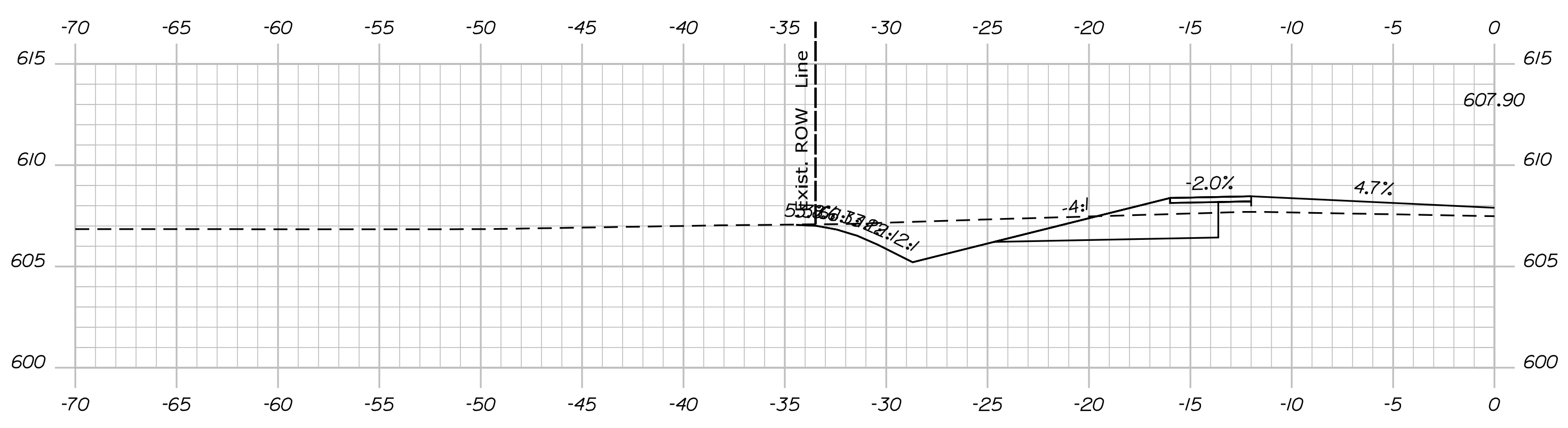

1098+19.00

STATE OF MAINE
 DEPARTMENT OF TRANSPORTATION
STP-1824(500)
 WIN
 18245.00
 HIGHWAY PLANS

PROJ. MANAGER	DATE	BY	DATE
DESIGN DETAILER			
CHECKED/REVIEWED			
DESIGN DETAILER			
DESIGN DETAILER			
REVISIONS 1			
REVISIONS 2			
REVISIONS 3			
REVISIONS 4			
FIELD CHANGES			

KINGFIELD
 ROUTE 16\27
 CROSS SECTIONS

SHEET NUMBER
Xse
 OF 175

Date: \$date\$

Username:

Division: HIGHWAY

Filename: ... \Bentley\ustrn\Xsect.dgn

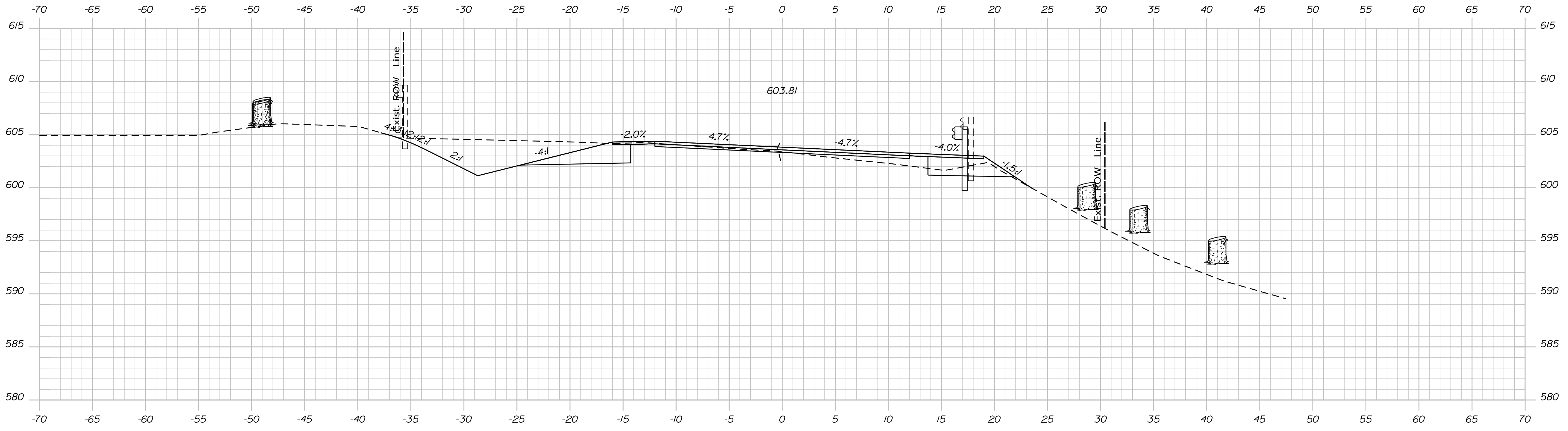

1099+50.00

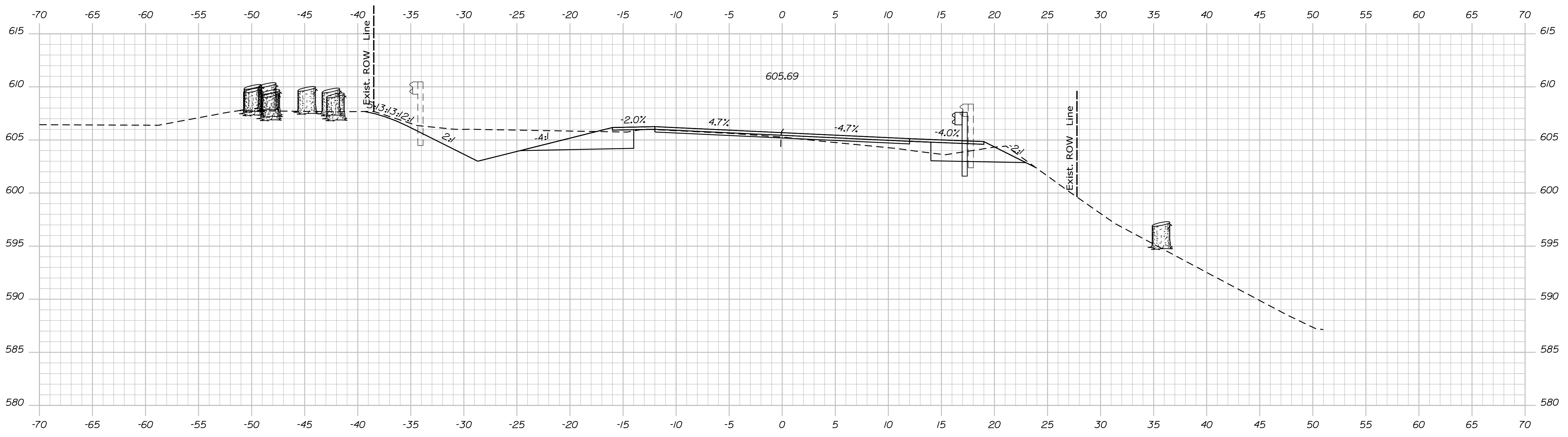

1099+00.00

STATE OF MAINE
DEPARTMENT OF TRANSPORTATION
STP-1824(500)

WIN
18245.00
HIERARCHIC PLANS

PROJ. MANAGER	DATE
DESIGN DETAILED	
CHECKED/REVIEWED	
DESIGN DETAILED	
DESIGN DETAILED	
REVISIONS 1	
REVISIONS 2	
REVISIONS 3	
REVISIONS 4	
FIELD CHANGES	

KINGFIELD
ROUTE 16\27
CROSS SECTIONS

SHEET NUMBER
Xse
OF 175

Date: \$date\$

Username:

Division: HIGHWAY

Filename: ... \Bentley\ustrn\Xsect.dgn

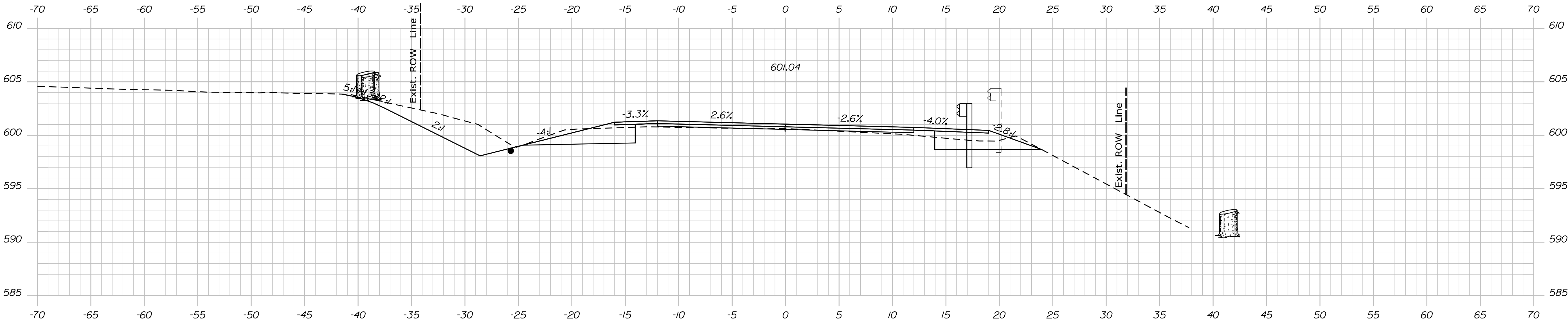

1100+50.00

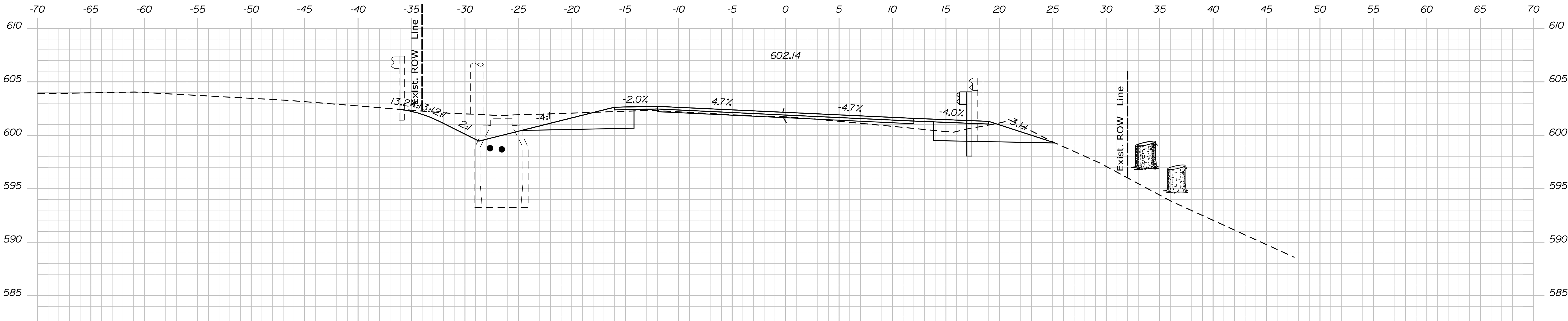

1100+00.00

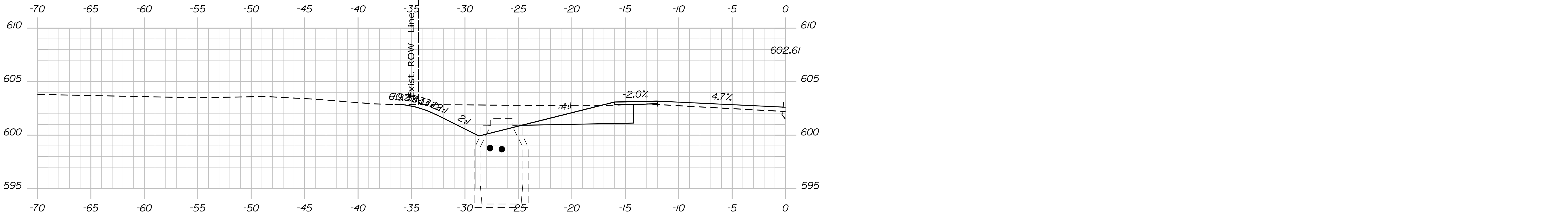

1099+84.00

STATE OF MAINE
DEPARTMENT OF TRANSPORTATION
STP-1824(500)
WIN
18245.00
HIGHWAY PLANS

SIGNATURE
P.E. NUMBER
DATE

PROJ. MANAGER	BY	DATE
DESIGN/DETAILED		
CHECKED/REVIEWED		
DESIGN/DETAILED		
DESIGN/DETAILED		
REVISIONS 1		
REVISIONS 2		
REVISIONS 3		
REVISIONS 4		
FIELD CHANGES		

KINGFIELD
ROUTE 16\27
CROSS SECTIONS

SHEET NUMBER
Xse
OF 175

Date: \$date\$

Username:

Division: HIGHWAY

Filename: ... \Bentley\ustrn\Xsect.dgn

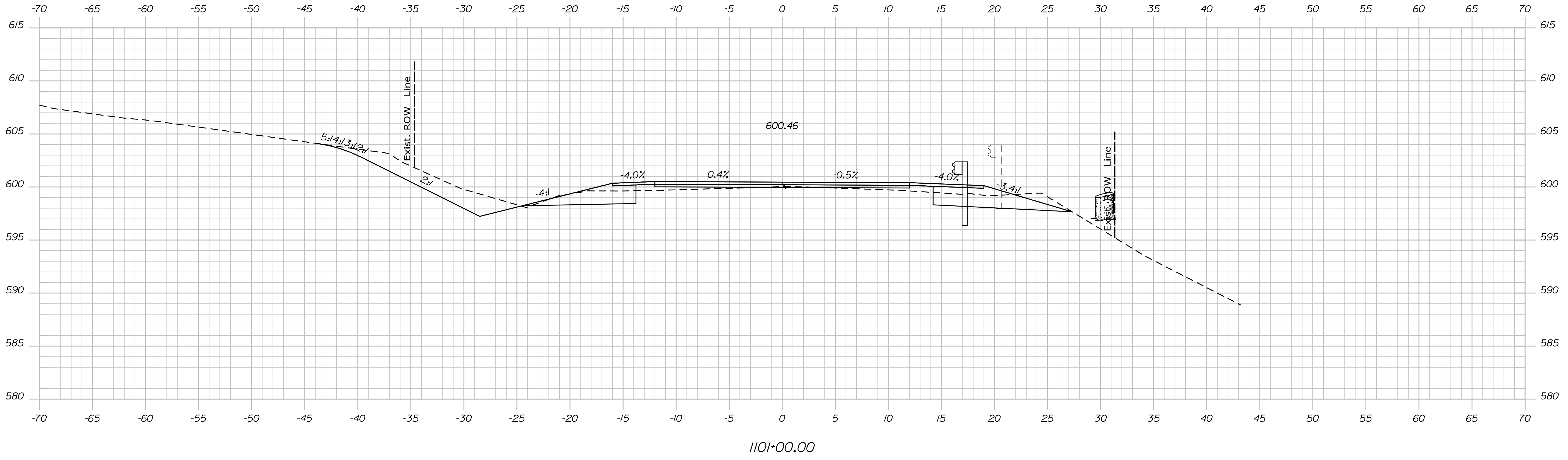
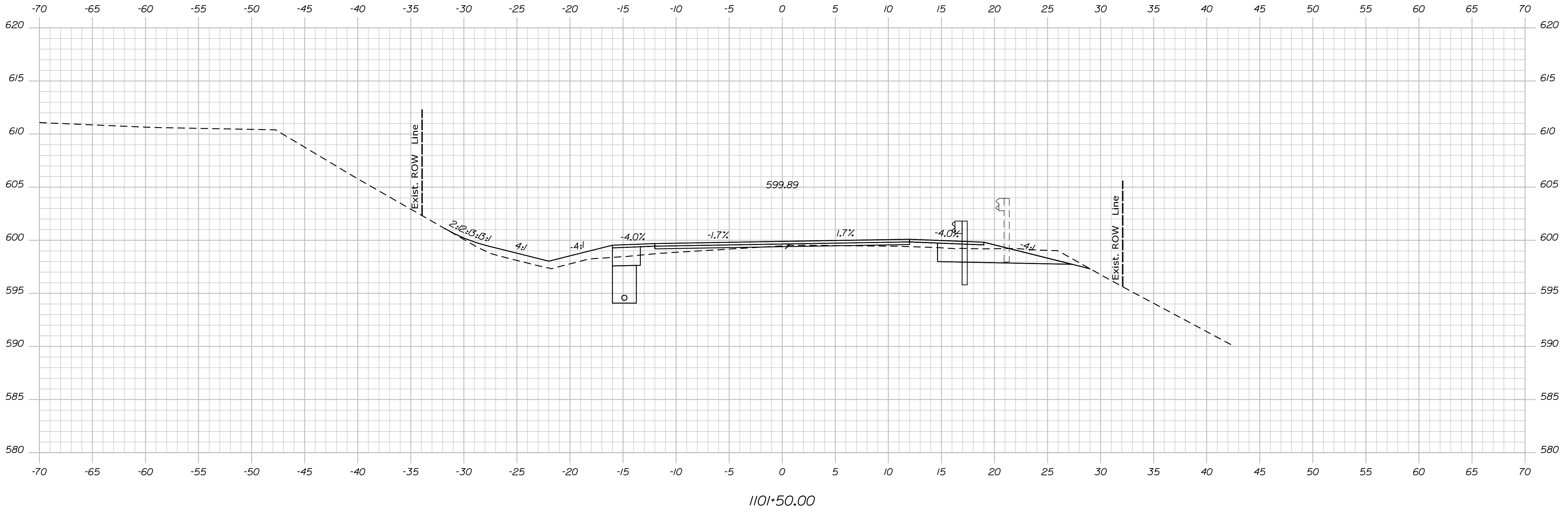

STATE OF MAINE
DEPARTMENT OF TRANSPORTATION
STP-1824(500)
WIN
18245.00
HIERARCHIC PLANS

SIGNATURE
P.E. NUMBER
DATE

PROJ. MANAGER	DATE
DESIGN DETAILED	
CHECKED/REVIEWED	
DESIGN DETAILED	
DESIGN DETAILED	
REVISIONS 1	
REVISIONS 2	
REVISIONS 3	
REVISIONS 4	
FIELD CHANGES	

KINGFIELD
ROUTE 16\27
CROSS SECTIONS

SHEET NUMBER
Xse
OF 175

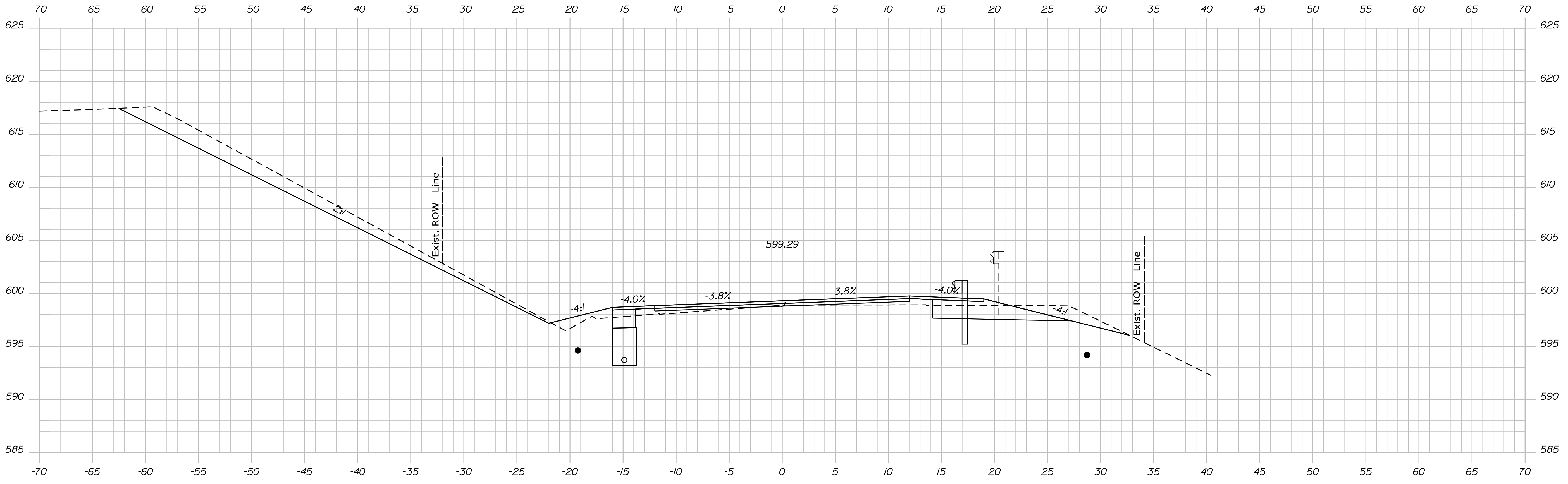

1102+00.00

STATE OF MAINE
 DEPARTMENT OF TRANSPORTATION
STP-1824(500)

WIN
 18245.00
 HIERARCHIC PLANS

PROJ. MANAGER	BY	DATE
DESIGN/DETAILED		
CHECKED/REVIEWED		
DESIGN/DETAILED		
DESIGN/DETAILED		
REVISIONS 1		
REVISIONS 2		
REVISIONS 3		
REVISIONS 4		
FIELD CHANGES		

KINGFIELD
 ROUTE 16\27
 CROSS SECTIONS

SHEET NUMBER
Xse
 OF 175

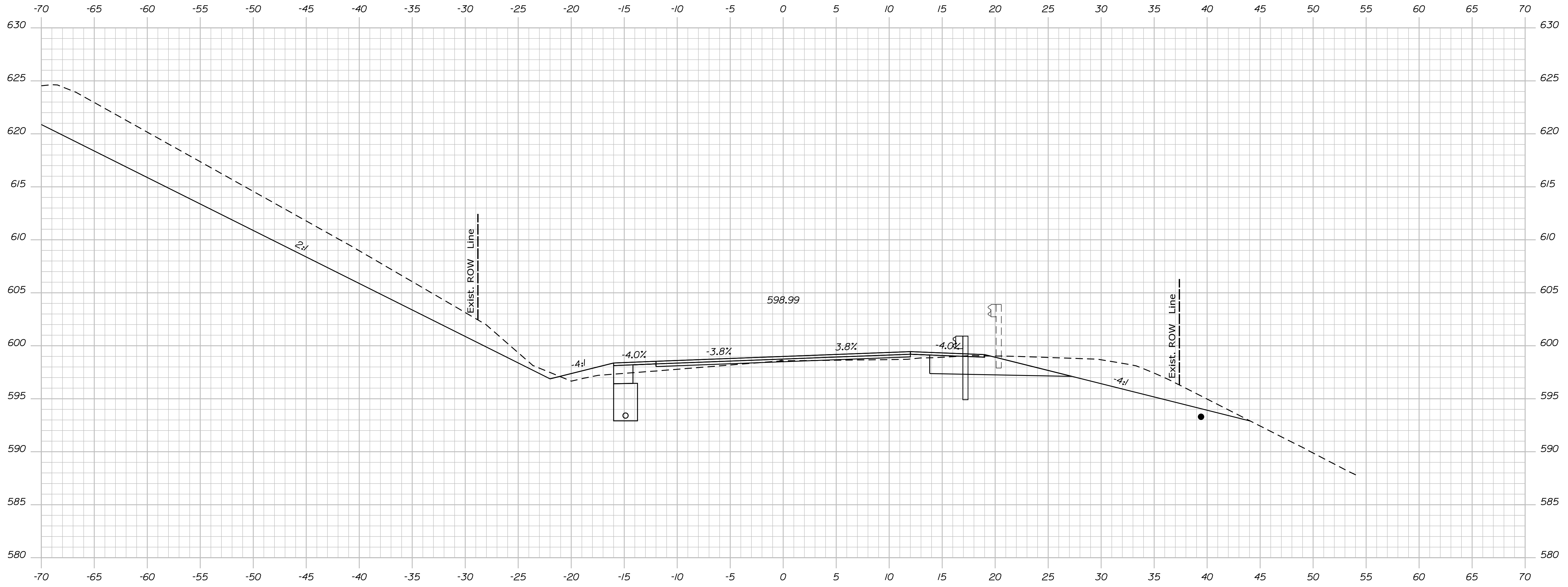

1102+50.00

STATE OF MAINE
 DEPARTMENT OF TRANSPORTATION
STP-1824(500)

WIN
 18245.00
 HIERARCHIC PLANS

PROJ. MANAGER	DATE
DESIGN DETAIL	SIGNATURE
CHECKED/REVIEWED	P.E. NUMBER
DESIGN DETAIL	DATE
DESIGN DETAIL	
REVISIONS 1	
REVISIONS 2	
REVISIONS 3	
REVISIONS 4	
FIELD CHANGES	

**KINGFIELD
 ROUTE 16\27
 CROSS SECTIONS**

SHEET NUMBER
Xse
 OF 175

Date: \$date\$

Username:

Division: HIGHWAY

Filename: ... \Bentley\ustrn\Xsect.dgn

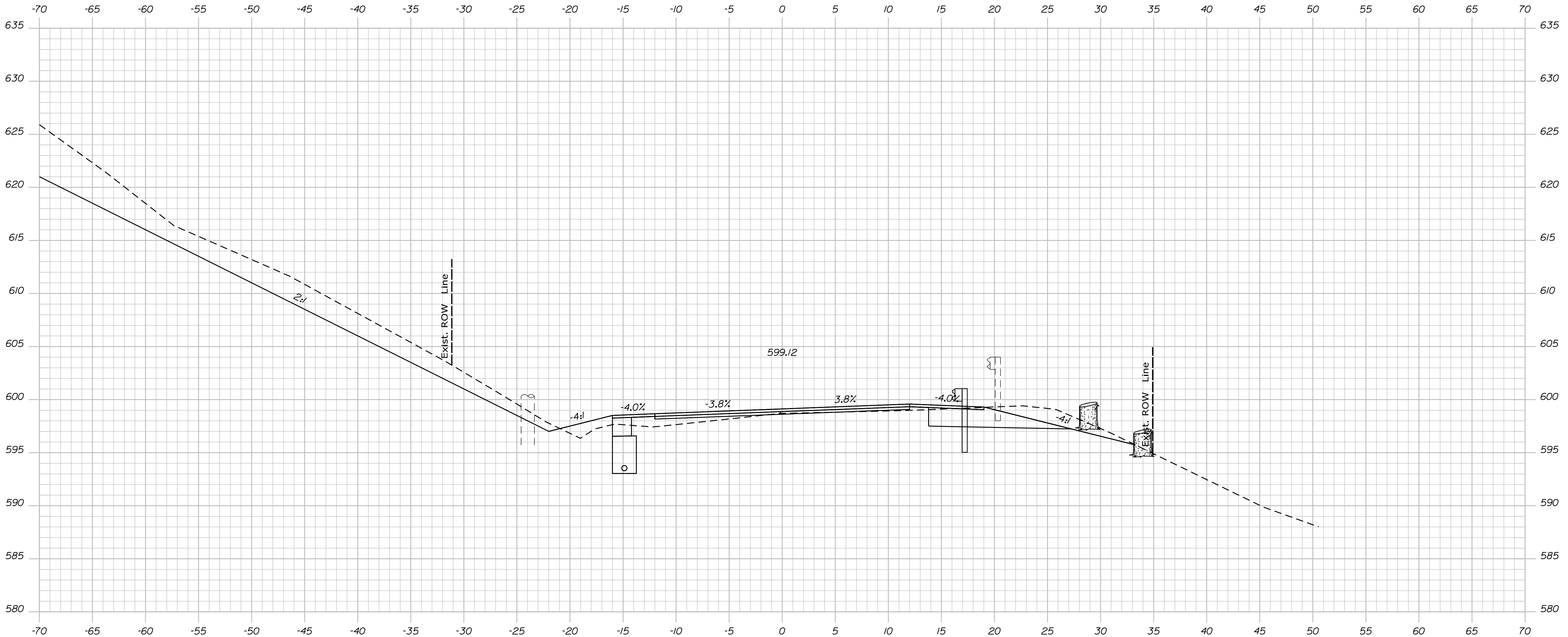

1103+00.00

Sta. 1103+00.00 to Sta. 1103+00.00

STATE OF MAINE
DEPARTMENT OF TRANSPORTATION
STP-1824(500)

SIGNATURE
P.E. NUMBER
DATE

PROJ. MANAGER	DATE
DESIGN/DETAILED	
CHECKED/REVIEWED	
DESIGN/DETAILED	
DESIGN/DETAILED	
REVISIONS 1	
REVISIONS 2	
REVISIONS 3	
REVISIONS 4	
FIELD CHANGES	

KINGFIELD
ROUTE 16\27
CROSS SECTIONS

SHEET NUMBER
Xse
OF 175

WIN
18245.00
HIERARCHIC PLANS

Date: \$date\$

Username:

Division: HIGHWAY

Filename: ... \Bentley\ustrn\Xsect.dgn

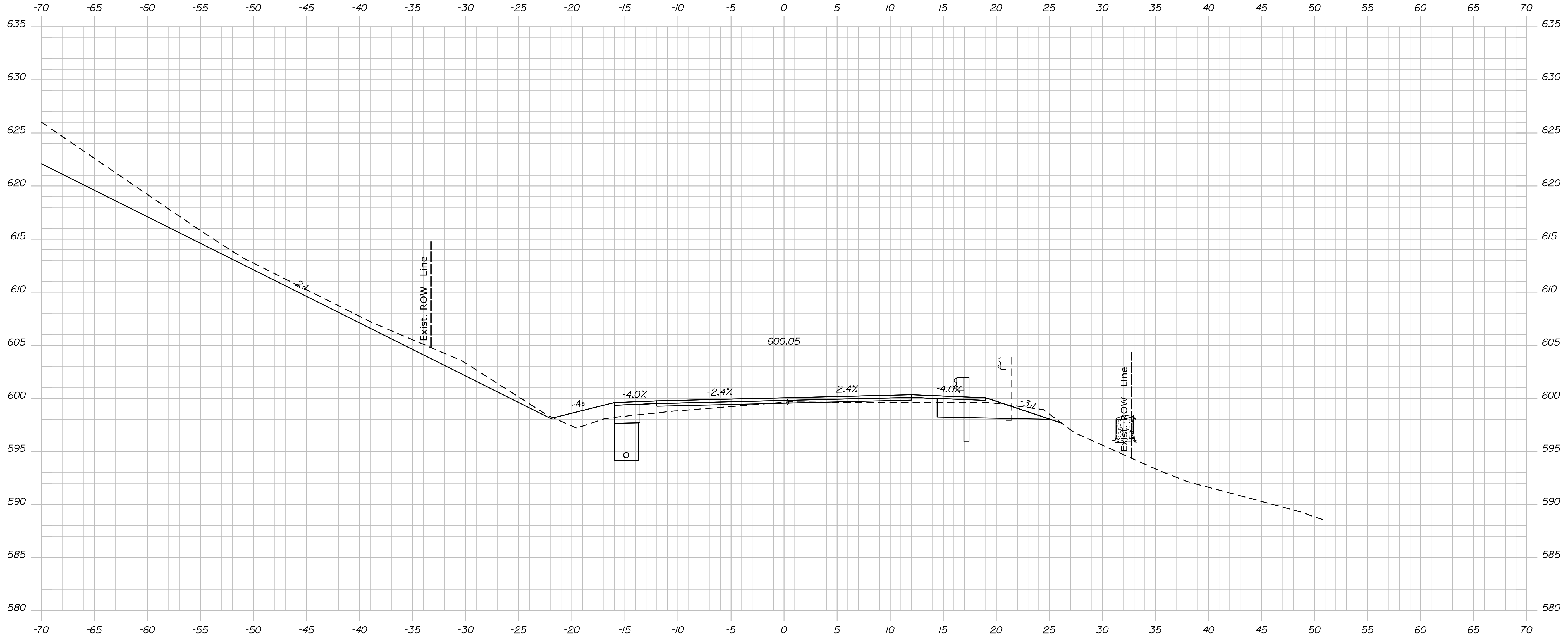

1104+00.00

Sta. 1104+00.00 to Sta. 1104+00.00

STATE OF MAINE
 DEPARTMENT OF TRANSPORTATION
STP-1824(500)

SIGNATURE
 P.E. NUMBER
 DATE

PROJ. MANAGER	BY	DATE
DESIGN DETAIL		
CHECKED/REVIEWED		
DESIGN DETAIL		
DESIGN DETAIL		
REVISIONS 1		
REVISIONS 2		
REVISIONS 3		
REVISIONS 4		
FIELD CHANGES		

KINGFIELD
 ROUTE 16\27
 CROSS SECTIONS

SHEET NUMBER
Xse
 OF 175

WIN 18245.00
HIERARCHIC PLANS

Date: \$date\$

Username:

Division: HIGHWAY

Filename: ... \Bentley\ustrn\Xsect.dgn

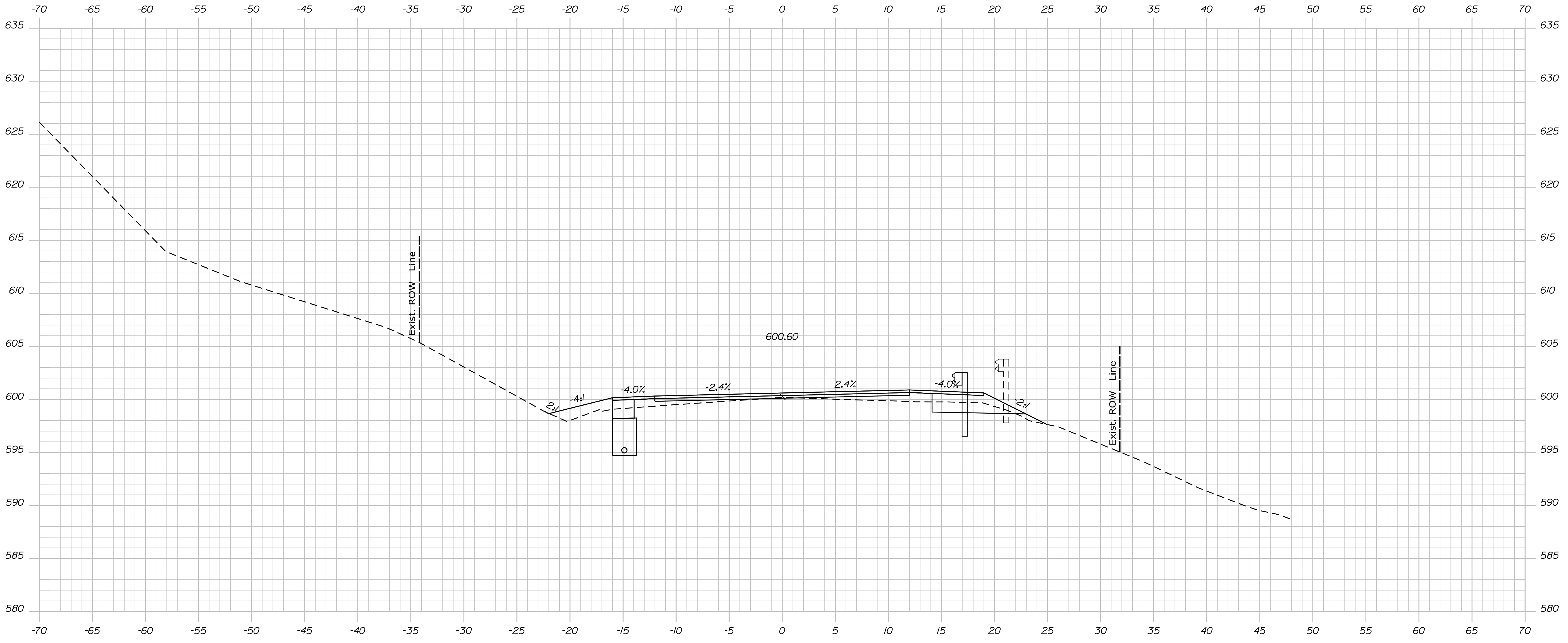

1104+50.00

Sta. 1104+50.00 to Sta. 1104+50.00

STATE OF MAINE
 DEPARTMENT OF TRANSPORTATION
STP-1824(500)

SIGNATURE _____
 P.E. NUMBER _____
 DATE _____

PROJ. MANAGER	BY	DATE
DESIGN DETAIL		
CHECKED/REVIEWED		
DESIGN DETAIL		
DESIGN DETAIL		
REVISIONS 1		
REVISIONS 2		
REVISIONS 3		
REVISIONS 4		
FIELD CHANGES		

**KINGFIELD
 ROUTE 16\27
 CROSS SECTIONS**

SHEET NUMBER
Xse
 OF 175

WIN
 18245.00
 HIERARCHIC PLANS

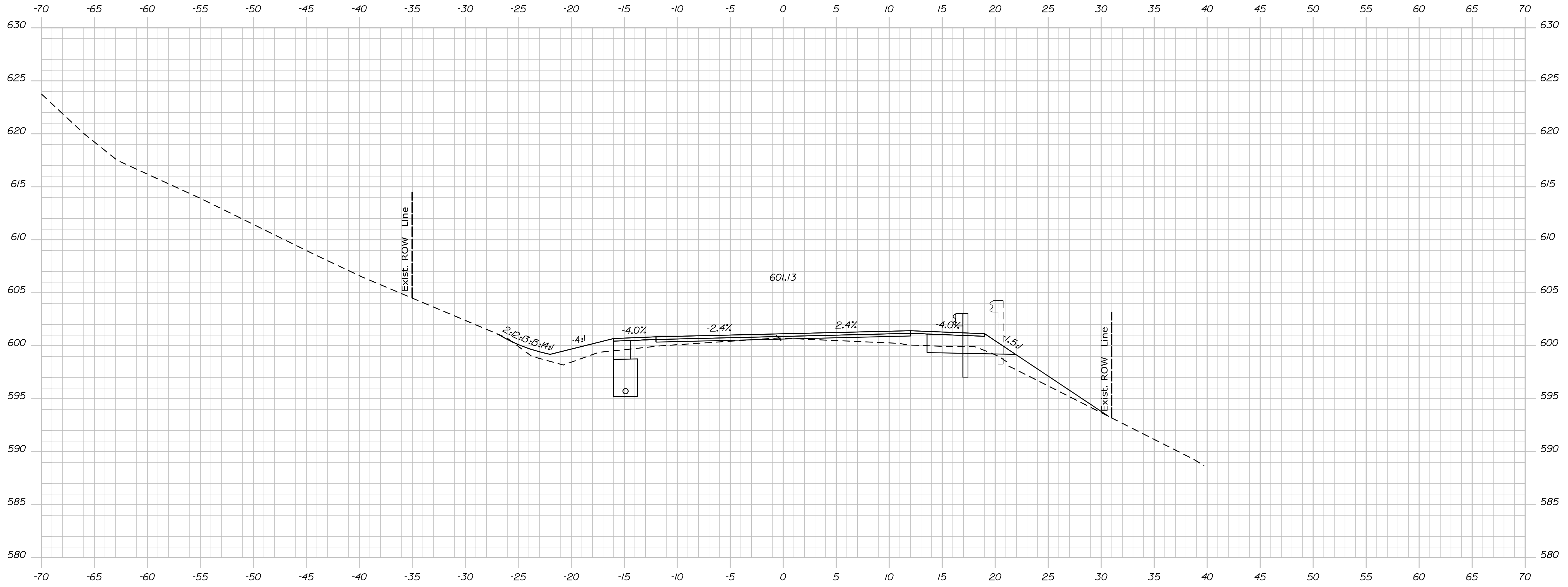

1105+00.00

STATE OF MAINE
 DEPARTMENT OF TRANSPORTATION
STP-1824(500)

WIN
 18245.00
 HIERARCHIC PLANS

PROJ. MANAGER	BY	DATE
DESIGN DETAILED		
CHECKED/REVIEWED		
DESIGN DETAILED		
DESIGN DETAILED		
REVISIONS 1		
REVISIONS 2		
REVISIONS 3		
REVISIONS 4		
FIELD CHANGES		

**KINGFIELD
 ROUTE 16\27
 CROSS SECTIONS**

SHEET NUMBER
Xse
 OF 175

Date: \$date\$

Username:

Division: HIGHWAY

Filename: ... \Bentley\ustrn\Xsect.dgn

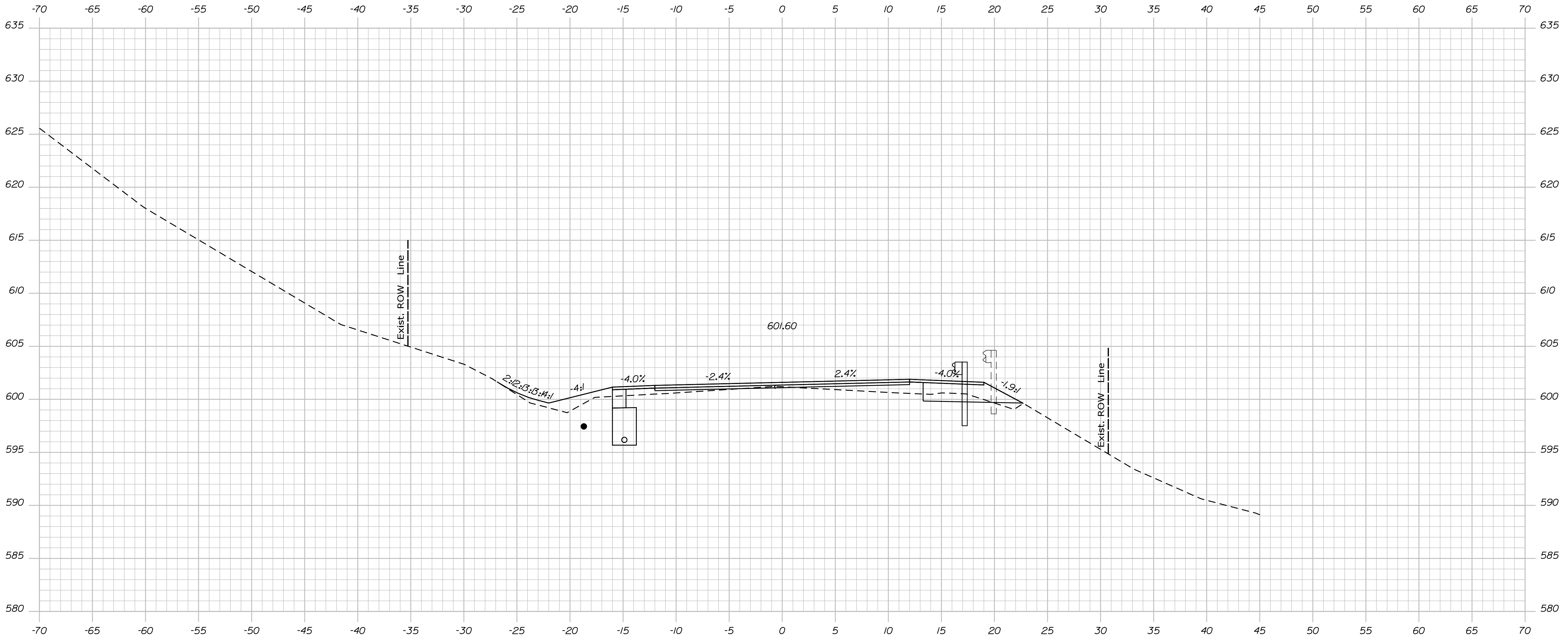

1105+50.00

STATE OF MAINE
 DEPARTMENT OF TRANSPORTATION
STP-1824(500)

SIGNATURE
 P.E. NUMBER
 DATE

PROJ. MANAGER	BY	DATE
DESIGN DETAILED		
CHECKED/REVIEWED		
DESIGN DETAILED		
DESIGN DETAILED		
REVISIONS 1		
REVISIONS 2		
REVISIONS 3		
REVISIONS 4		
FIELD CHANGES		

**KINGFIELD
 ROUTE 16\27
 CROSS SECTIONS**

SHEET NUMBER
Xse
 OF 175

WIN
 18245.00
 HIERARCHIC PLANS

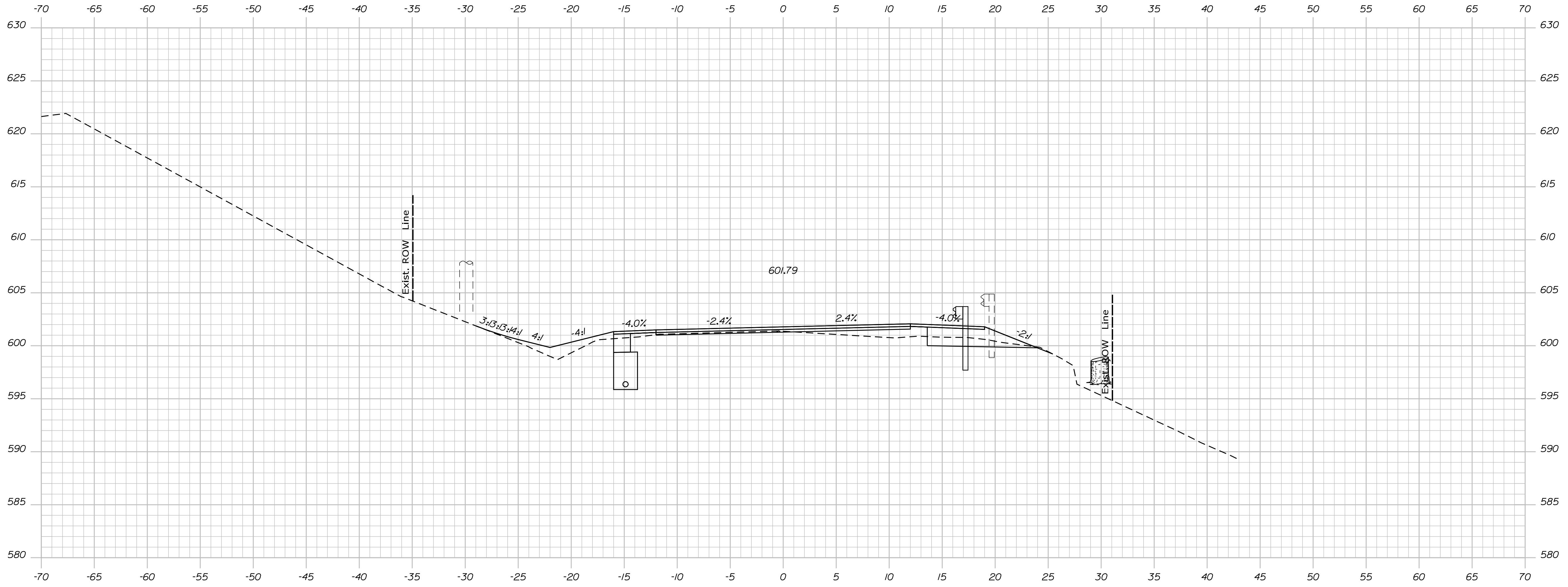

1106+00.00

STATE OF MAINE
 DEPARTMENT OF TRANSPORTATION
STP-1824(500)

SIGNATURE
 P.E. NUMBER
 DATE

PROJ. MANAGER	DATE
DESIGN DETAILED	
CHECKED/REVIEWED	
DESIGN DETAILED	
DESIGN DETAILED	
REVISIONS 1	
REVISIONS 2	
REVISIONS 3	
REVISIONS 4	
FIELD CHANGES	

**KINGFIELD
 ROUTE 16\27**
CROSS SECTIONS

SHEET NUMBER
Xse
 OF 175

WIN
 18245.00
 HIERARCHIC PLANS

Date: \$date\$

Username:

Division: HIGHWAY

Filename: ... \Bentley\ustrn\Xsect.dgn

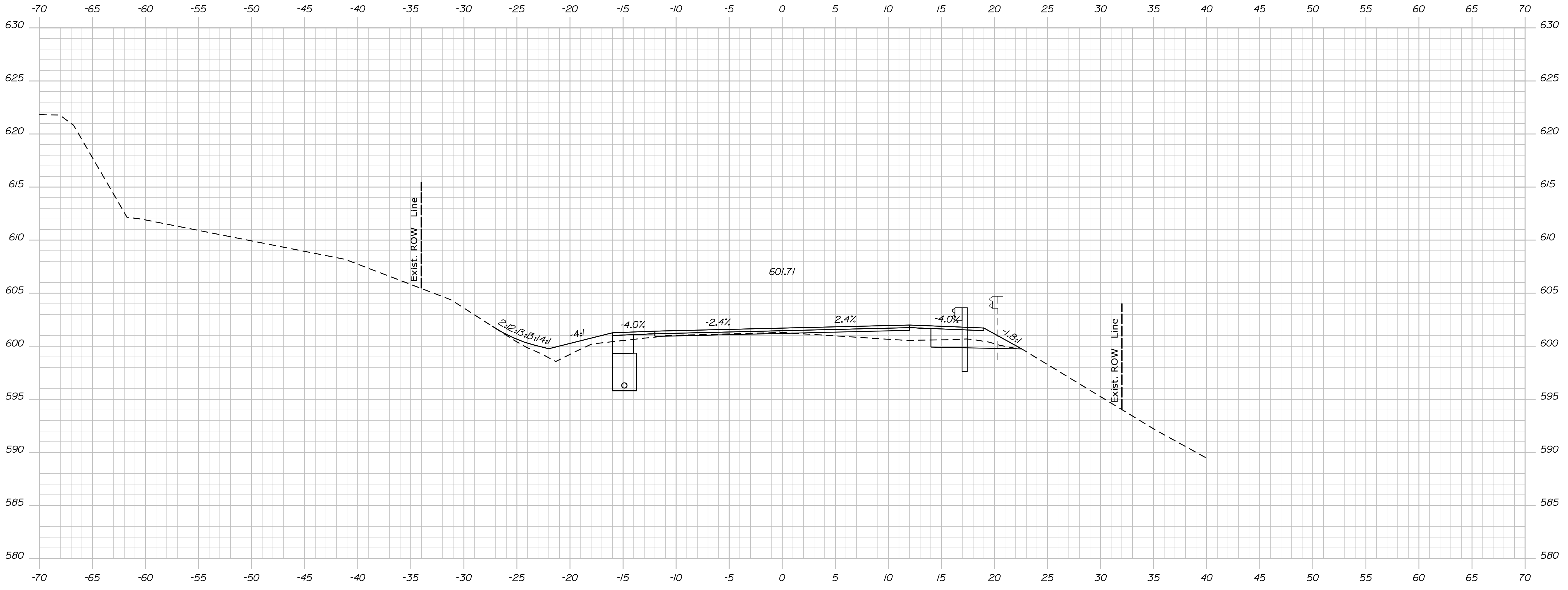

1106+50.00

STATE OF MAINE
 DEPARTMENT OF TRANSPORTATION
STP-1824(500)

SIGNATURE
 P.E. NUMBER
 DATE

PROJ. MANAGER	DATE
DESIGN DETAIL	
CHECKED/REVIEWED	
DESIGN DETAIL	
DESIGN DETAIL	
REVISIONS 1	
REVISIONS 2	
REVISIONS 3	
REVISIONS 4	
FIELD CHANGES	

**KINGFIELD
 ROUTE 16\27**
CROSS SECTIONS

SHEET NUMBER
Xse
 OF 175

WIN
 18245.00
 HIERARCHIC PLANS

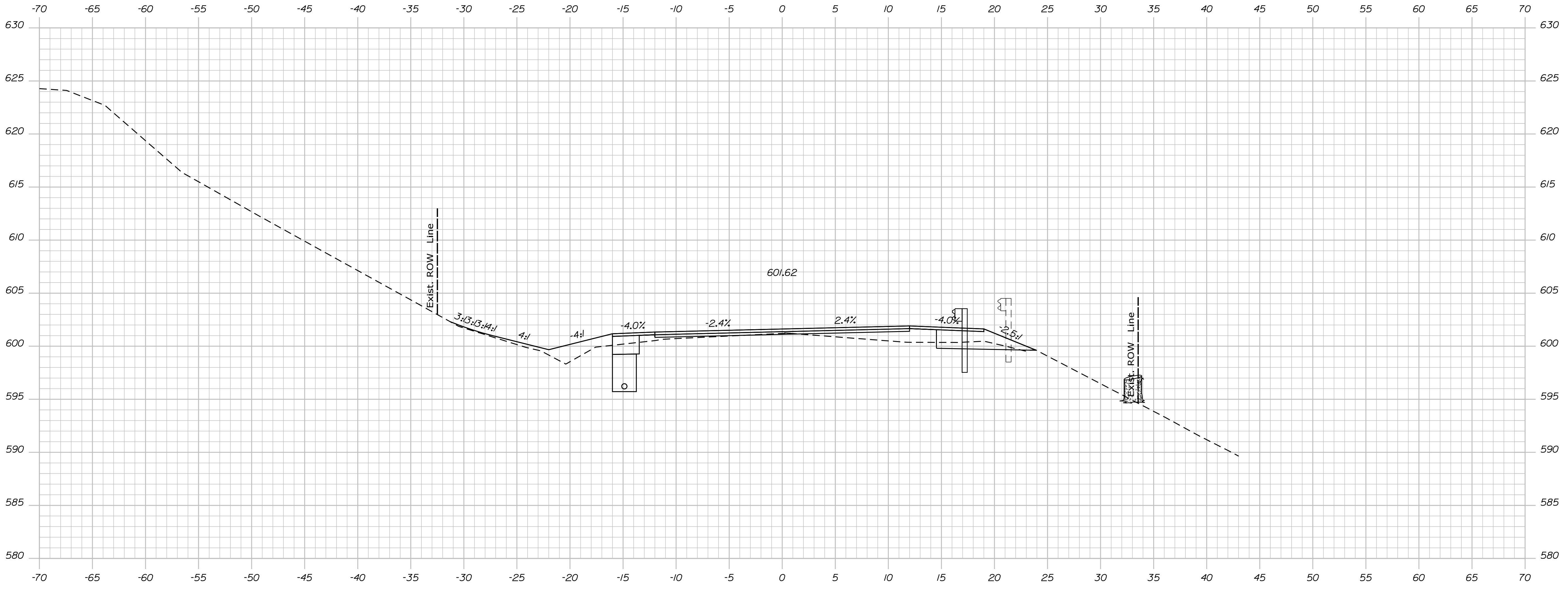

1107+00.00

STATE OF MAINE
DEPARTMENT OF TRANSPORTATION
STP-1824(500)

SIGNATURE
P.E. NUMBER
DATE

PROJ. MANAGER	DATE
DESIGN DETAILER	
CHECKED/REVIEWED	
DESIGN DETAILER	
DESIGN DETAILER	
REVISIONS 1	
REVISIONS 2	
REVISIONS 3	
REVISIONS 4	
FIELD CHANGES	

KINGFIELD
ROUTE 16\27
CROSS SECTIONS

SHEET NUMBER
Xse
OF 175

WIN
18245.00
HIERARCHIC PLANS

Date: \$date\$

Username:

Division: HIGHWAY

Filename: ... \Bentley\ustrn\Xsect.dgn

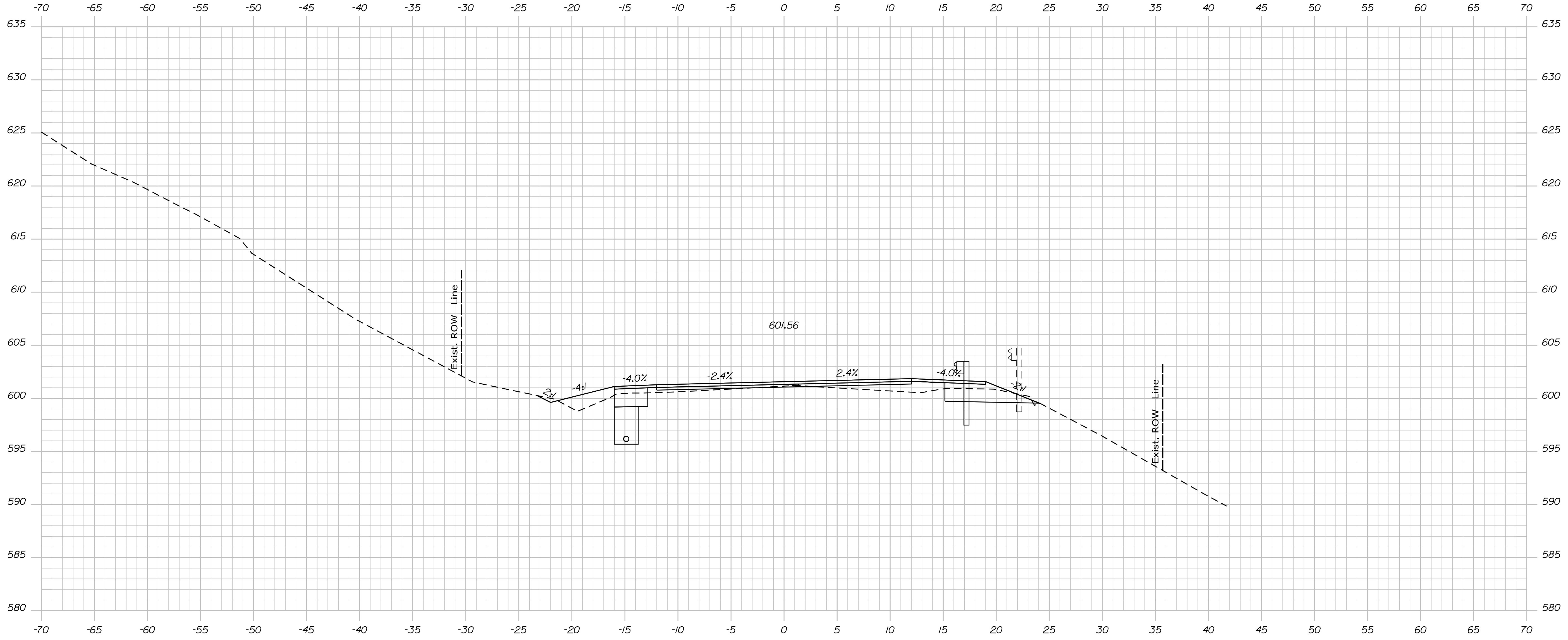

1107+50.00

Sta. 1107+50.00 to Sta. 1107+50.00

STATE OF MAINE
DEPARTMENT OF TRANSPORTATION
STP-1824(500)

SIGNATURE
P.E. NUMBER
DATE

PROJ. MANAGER	BY	DATE
DESIGN DETAILED		
CHECKED/REVIEWED		
DESIGN DETAILED		
DESIGN DETAILED		
REVISIONS 1		
REVISIONS 2		
REVISIONS 3		
REVISIONS 4		
FIELD CHANGES		

KINGFIELD
ROUTE 16\27
CROSS SECTIONS

SHEET NUMBER
Xse
OF 175

WIN 18245.00
HIERARCHIC PLANS

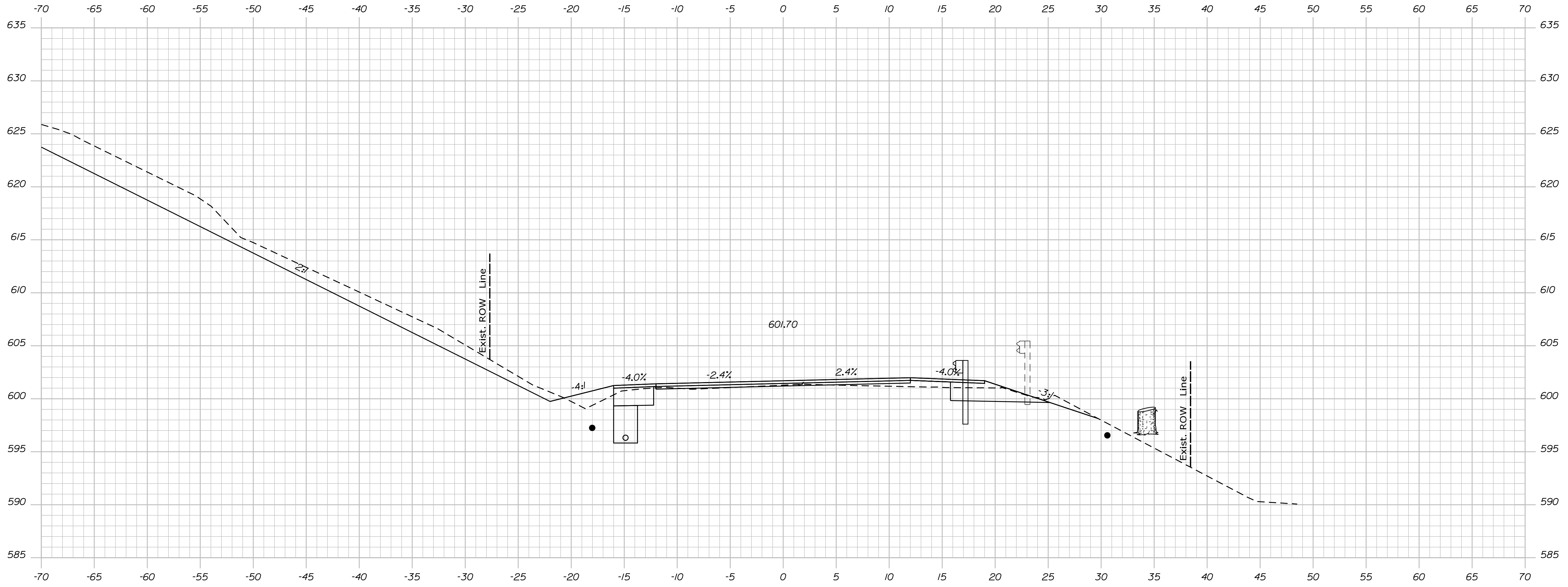

1108+00.00

STATE OF MAINE
 DEPARTMENT OF TRANSPORTATION
STP-1824(500)

SIGNATURE
 P.E. NUMBER
 DATE

PROJ. MANAGER	DATE
DESIGN DETAIL	
CHECKED/REVIEWED	
DESIGN DETAIL	
DESIGN DETAIL	
REVISIONS 1	
REVISIONS 2	
REVISIONS 3	
REVISIONS 4	
FIELD CHANGES	

KINGFIELD
 ROUTE 16\27
 CROSS SECTIONS

SHEET NUMBER
Xse
 OF 175

WIN
 18245.00
 HIGHWAY PLANS

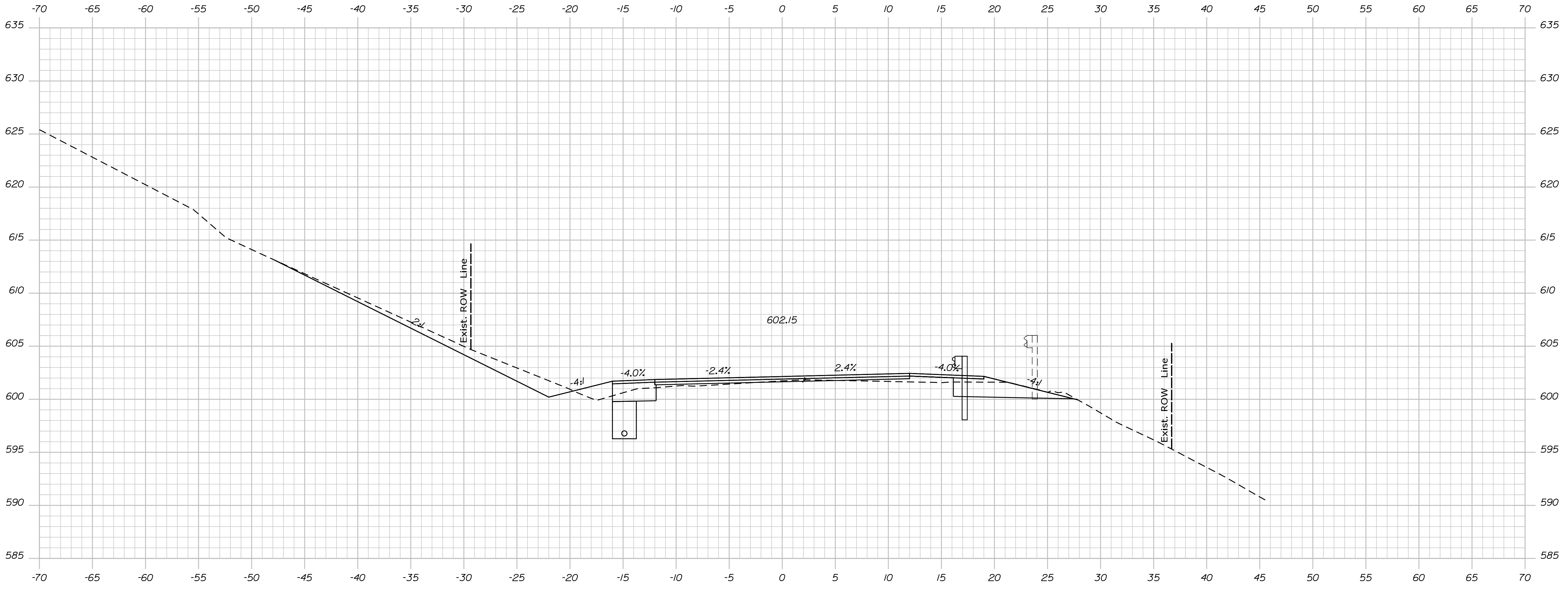

1108+50.00

STATE OF MAINE
 DEPARTMENT OF TRANSPORTATION
STP-1824(500)

WIN
 18245.00
 HIERARCHIC PLANS

PROJ. MANAGER	DATE
DESIGN DETAIL	
CHECKED/REVIEWED	
DESIGN DETAIL	
DESIGN DETAIL	
REVISIONS 1	
REVISIONS 2	
REVISIONS 3	
REVISIONS 4	
FIELD CHANGES	

KINGFIELD
 ROUTE 16\27
 CROSS SECTIONS

SHEET NUMBER
Xse
 OF 175

Date: \$date\$

Username:

Division: HIGHWAY

Filename: ... \Bentley\ustrn\Xsect.dgn

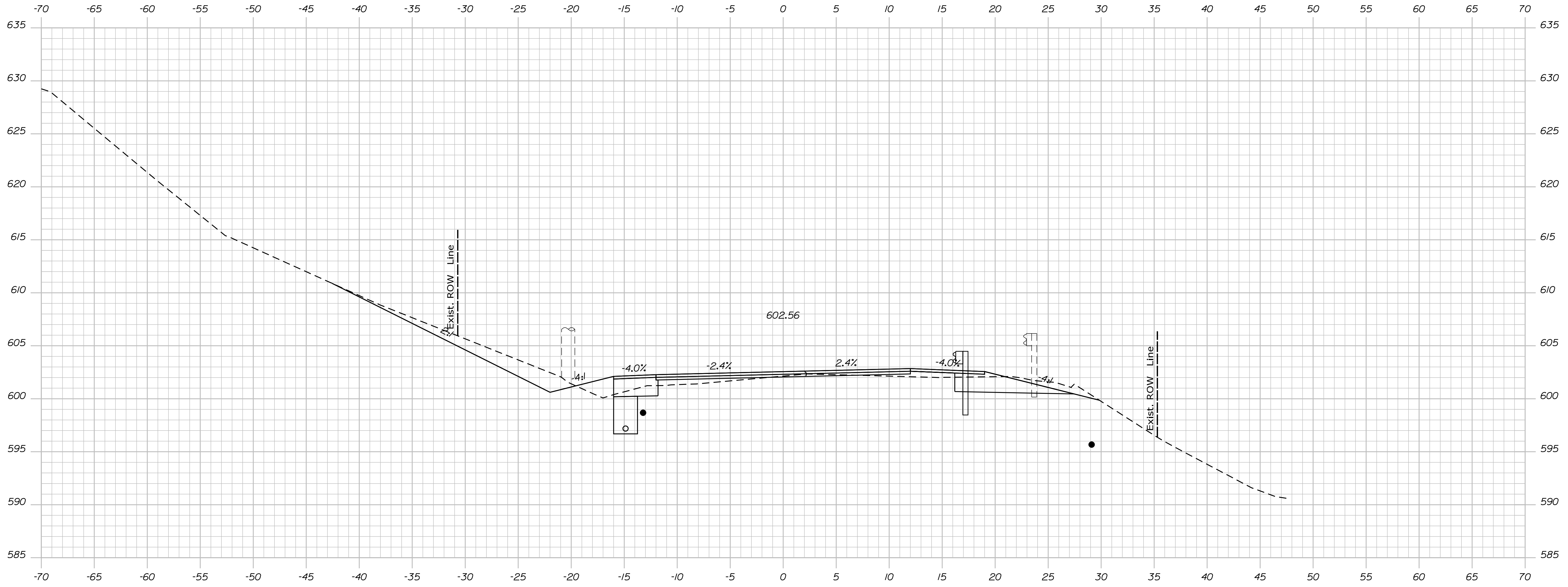

1109+00.00

Sta. 1109+00.00 to Sta. 1109+00.00

STATE OF MAINE
 DEPARTMENT OF TRANSPORTATION
STP-1824(500)

WIN
 18245.00
 HIERARCHIC PLANS

PROJ. MANAGER	DATE
DESIGN DETAILED	
CHECKED/REVIEWED	
DESIGN DETAILED	
DESIGN DETAILED	
REVISIONS 1	
REVISIONS 2	
REVISIONS 3	
REVISIONS 4	
FIELD CHANGES	

**KINGFIELD
 ROUTE 16\27
 CROSS SECTIONS**

SHEET NUMBER
Xse
 OF 175

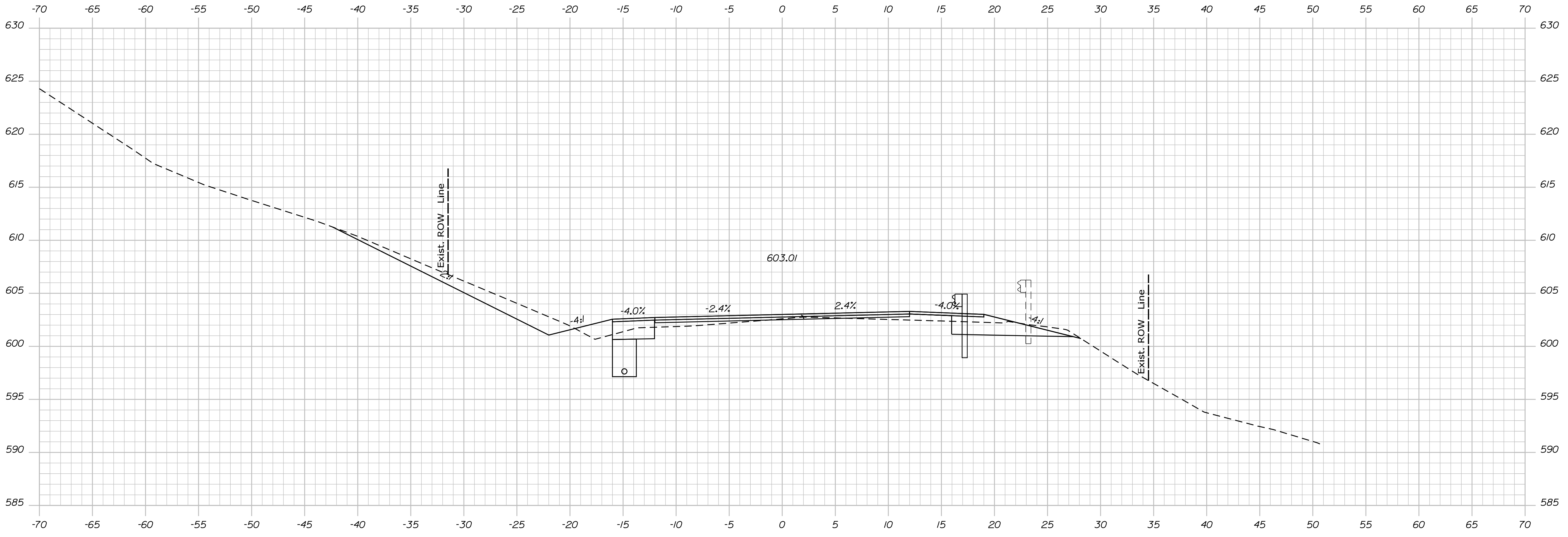

STATE OF MAINE
DEPARTMENT OF TRANSPORTATION
STP-1824(500)

SIGNATURE
P.E. NUMBER
DATE

PROJ. MANAGER	BY	DATE
DESIGN DETAILED		
CHECKED/REVIEWED		
DESIGN DETAILED		
DESIGN DETAILED		
REVISIONS 1		
REVISIONS 2		
REVISIONS 3		
REVISIONS 4		
FIELD CHANGES		

**KINGFIELD
ROUTE 16\27
CROSS SECTIONS**

SHEET NUMBER
Xse
OF 175

WIN
18245.00
HIERARCHIC PLANS

Date: \$date\$

Username:

Division: HIGHWAY

Filename: ... \Bentley\ustrn\Xsect.dgn

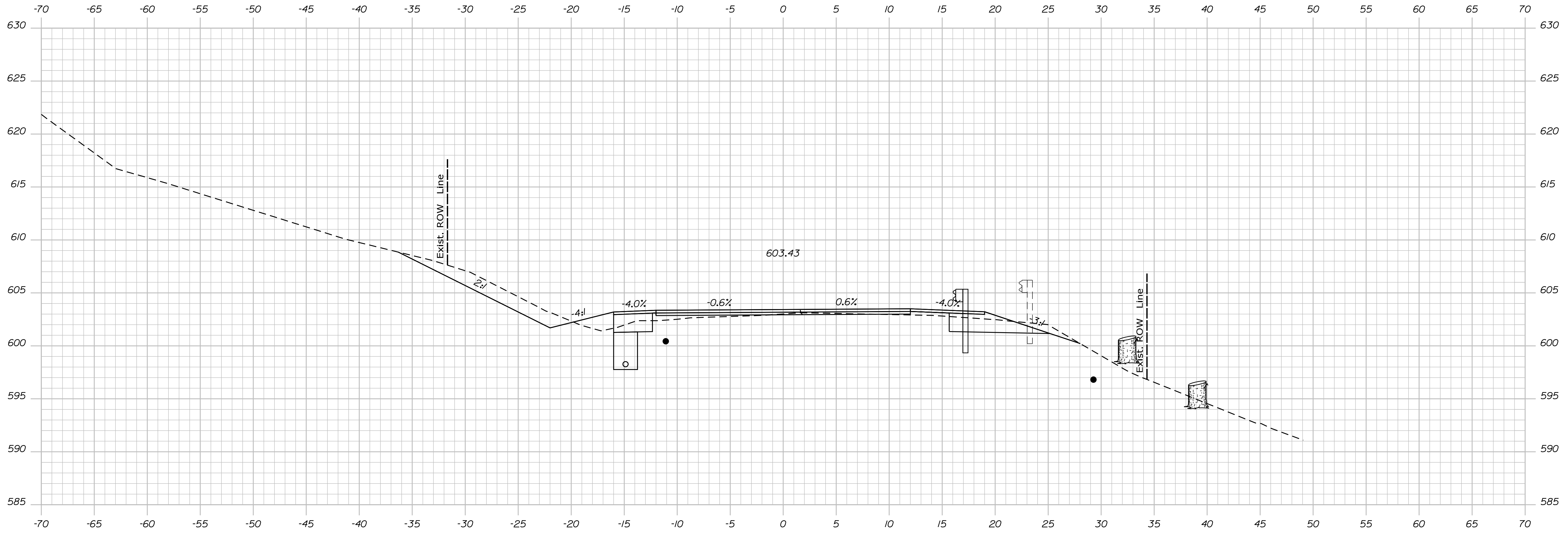

1110+00.00

Sta. 1110+00.00 to Sta. 1110+00.00

STATE OF MAINE
 DEPARTMENT OF TRANSPORTATION
STP-1824(500)

WIN
 18245.00
 HIERARCHIC PLANS

PROJ. MANAGER	BY	DATE
DESIGN DETAILED		
CHECKED/REVIEWED		
DESIGN DETAILED		
DESIGN DETAILED		
REVISIONS 1		
REVISIONS 2		
REVISIONS 3		
REVISIONS 4		
FIELD CHANGES		

KINGFIELD
 ROUTE 16\27
 CROSS SECTIONS

SHEET NUMBER
Xse
 OF 175

Date: \$date\$

Username:

Division: HIGHWAY

Filename: ... \Bentley\ustrn\Xsect.dgn

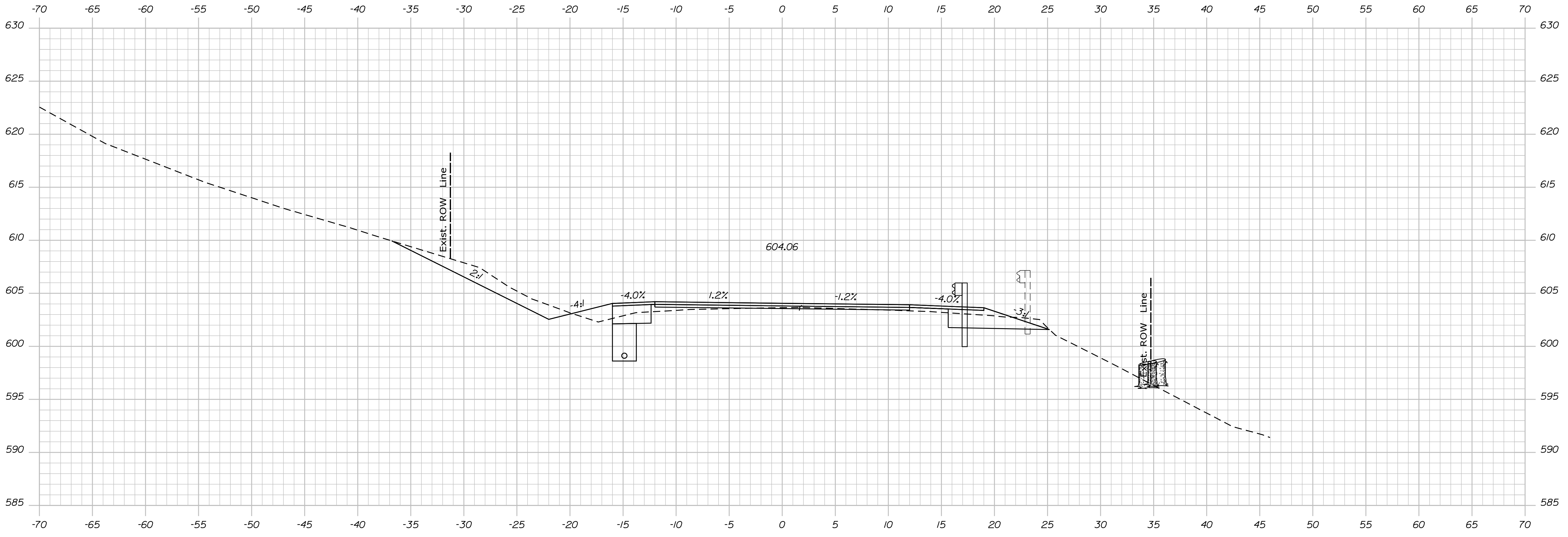

STATE OF MAINE
 DEPARTMENT OF TRANSPORTATION
STP-1824(500)

WIN
 18245.00
 HIERARCHIC PLANS

PROJ. MANAGER	BY	DATE
DESIGN DETAILED		
CHECKED/REVIEWED		
DESIGN DETAILED		
DESIGN DETAILED		
REVISIONS 1		
REVISIONS 2		
REVISIONS 3		
REVISIONS 4		
FIELD CHANGES		

KINGFIELD
 ROUTE 16\27
 CROSS SECTIONS

SHEET NUMBER
Xse
 OF 175

Date: \$date\$

Username:

Division: HIGHWAY

Filename: ... \Bentley\ustrn\Xsect.dgn

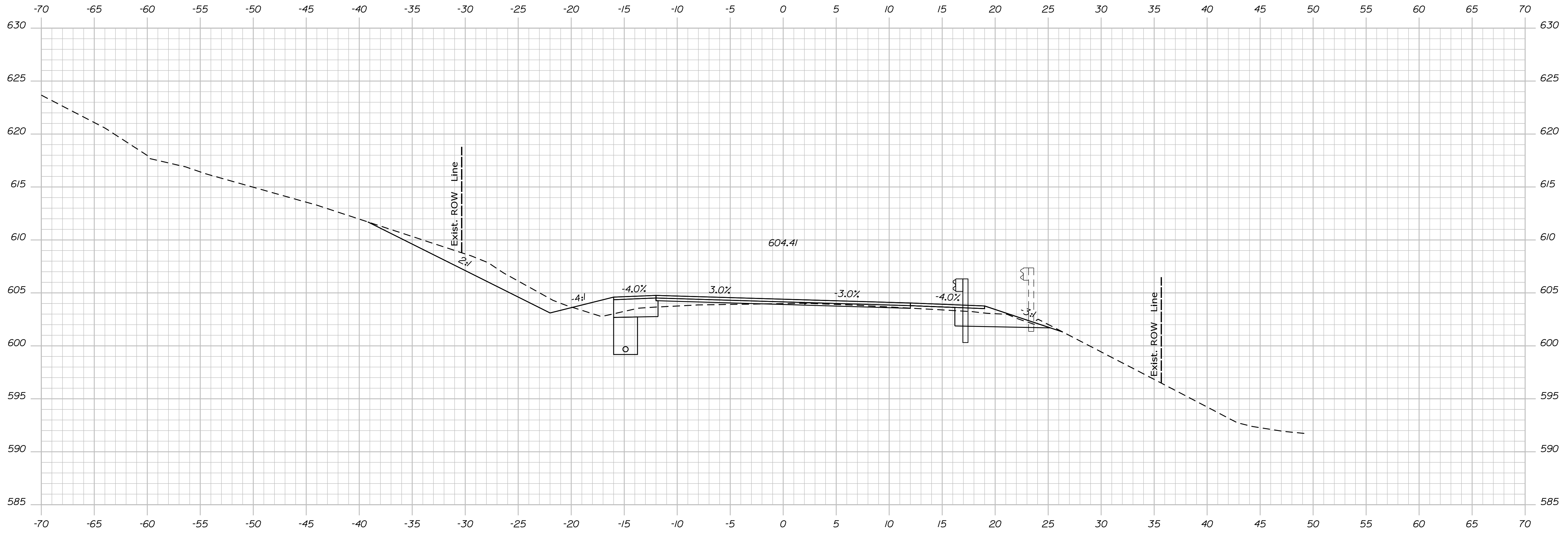

1111+00.00

Sta. 1111+00.00 to Sta. 1111+00.00

STATE OF MAINE
 DEPARTMENT OF TRANSPORTATION
STP-1824(500)

WIN
 18245.00
 HIERARCHIC PLANS

PROJ. MANAGER	BY	DATE
DESIGN DETAIL		
CHECKED/REVISED		
DESIGN DETAIL		
DESIGN DETAIL		
REVISIONS 1		
REVISIONS 2		
REVISIONS 3		
REVISIONS 4		
FIELD CHANGES		

KINGFIELD
 ROUTE 16\27
 CROSS SECTIONS

SHEET NUMBER
Xse
 OF 175

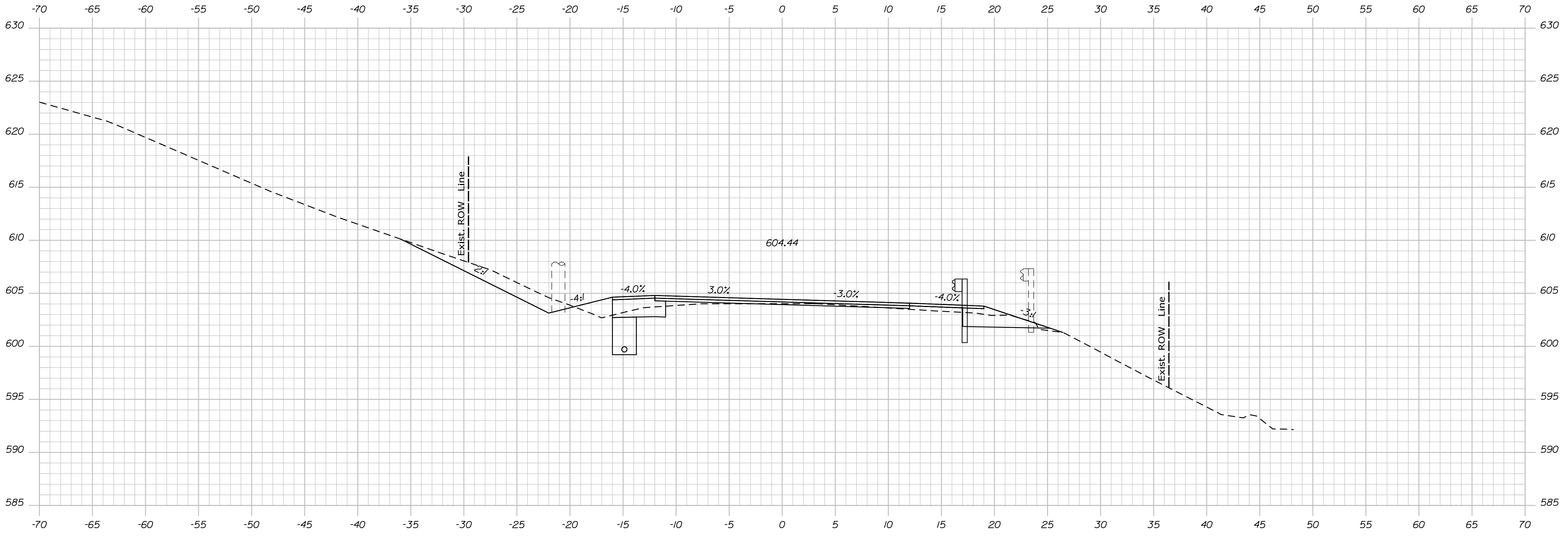

1/111+50.00

Sta. 1111+50.00 to Sta. 1111+50.00

STATE OF MAINE
 DEPARTMENT OF TRANSPORTATION
STP-1824(500)

WIN
 18245.00
 HIERARCHIC PLANS

PROJ. MANAGER	BY	DATE
DESIGN DETAIL		
CHECKED/REVIEWED		
DESIGN DETAIL		
DESIGN DETAIL		
REVISIONS 1		
REVISIONS 2		
REVISIONS 3		
REVISIONS 4		
FIELD CHANGES		

**KINGFIELD
 ROUTE 16\27
 CROSS SECTIONS**

SHEET NUMBER
Xse
 OF 175

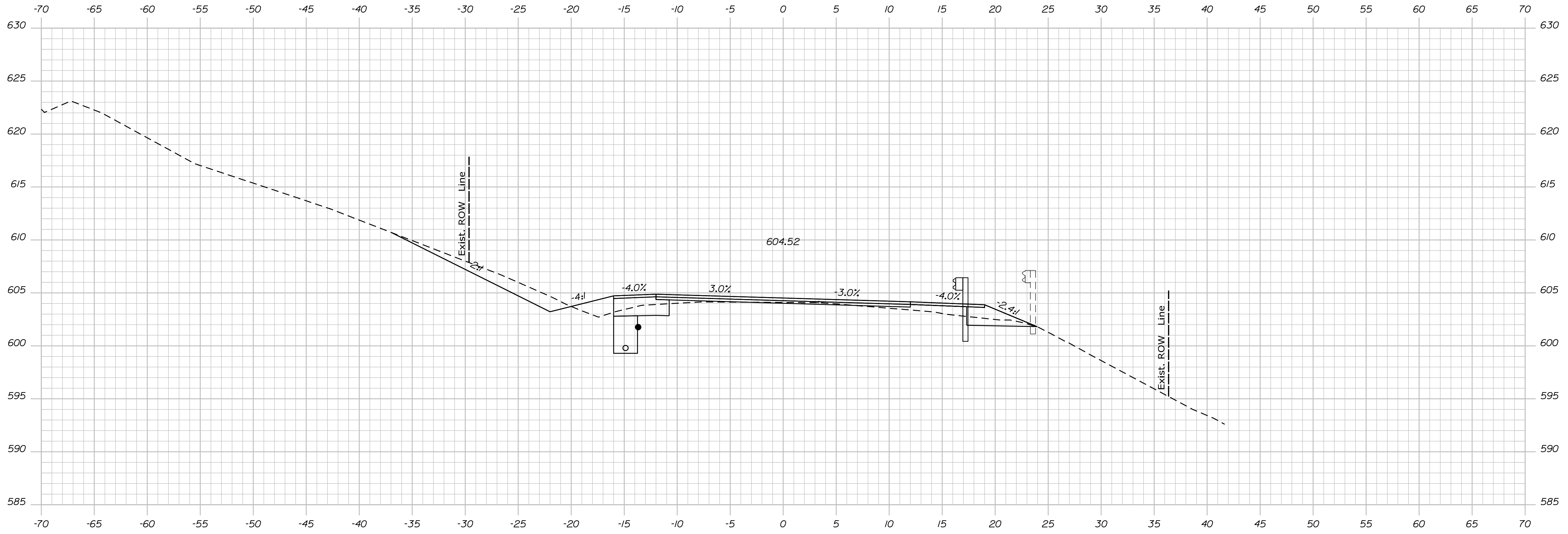

1112+00.00

STATE OF MAINE
 DEPARTMENT OF TRANSPORTATION
STP-1824(500)

WIN
 18245.00
 HIERARCHIC PLANS

PROJ. MANAGER	BY	DATE
DESIGN DETAILED		
CHECKED/REVISED		
DESIGN DETAILED		
DESIGN DETAILED		
REVISIONS 1		
REVISIONS 2		
REVISIONS 3		
REVISIONS 4		
FIELD CHANGES		

**KINGFIELD
 ROUTE 16\27
 CROSS SECTIONS**

SHEET NUMBER
Xse
 OF 175

Date: \$date\$

Username:

Division: HIGHWAY

Filename: ... \Bentley\ustn\Xsect.dgn

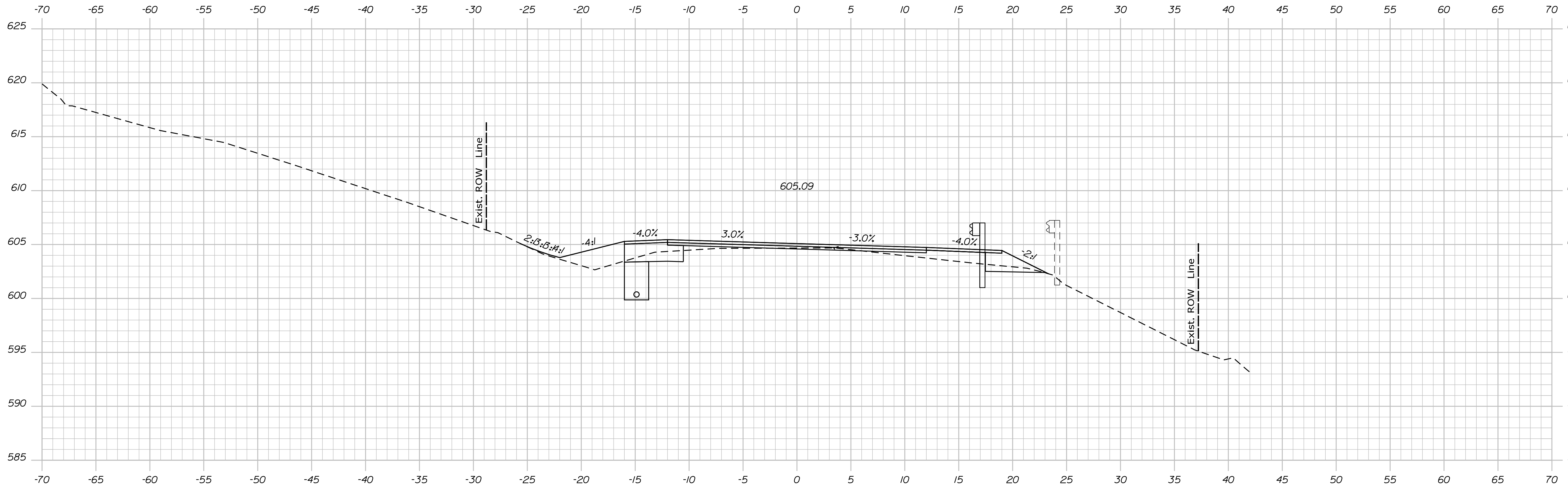

1113+00.00

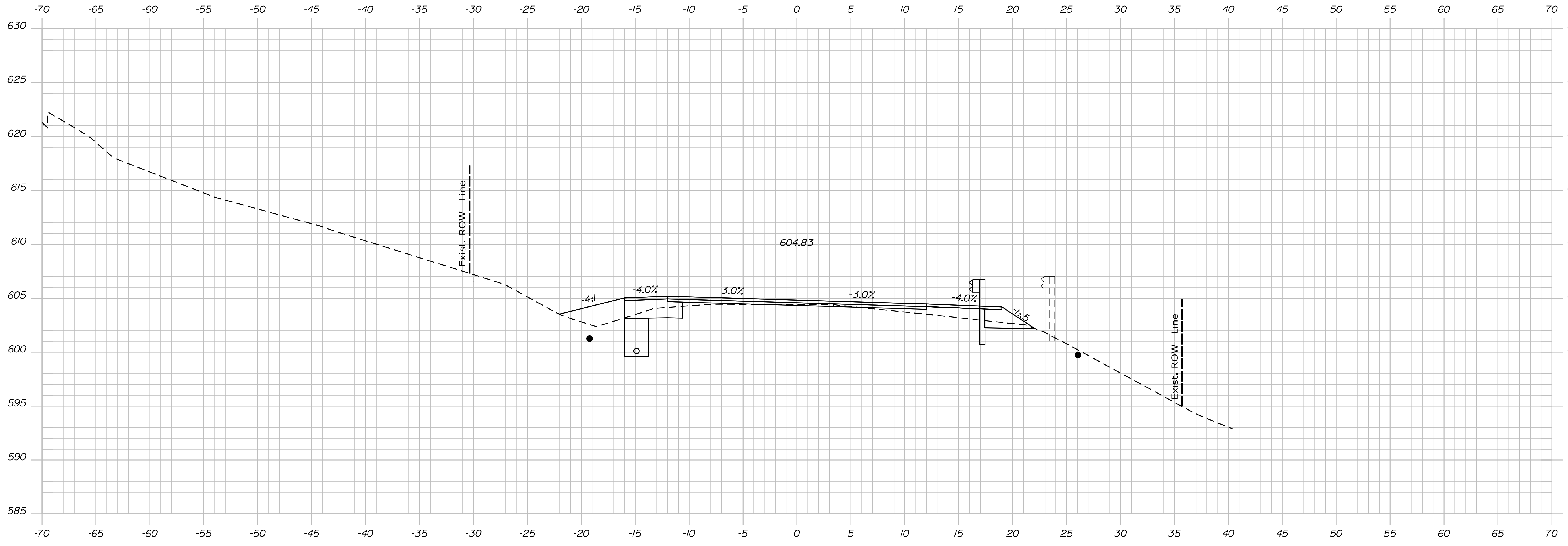

1112+50.00

STATE OF MAINE
DEPARTMENT OF TRANSPORTATION
STP-1824(500)
WIN
18245.00
HIGHWAY PLANS

SIGNATURE
P.E. NUMBER
DATE

PROJ. MANAGER	DATE
DESIGN DETAIL	
CHECKED/REVISED	
DESIGN DETAIL	
DESIGN DETAIL	
REVISIONS 1	
REVISIONS 2	
REVISIONS 3	
REVISIONS 4	
FIELD CHANGES	

KINGFIELD
ROUTE 16\27
CROSS SECTIONS

SHEET NUMBER
Xse
OF 175

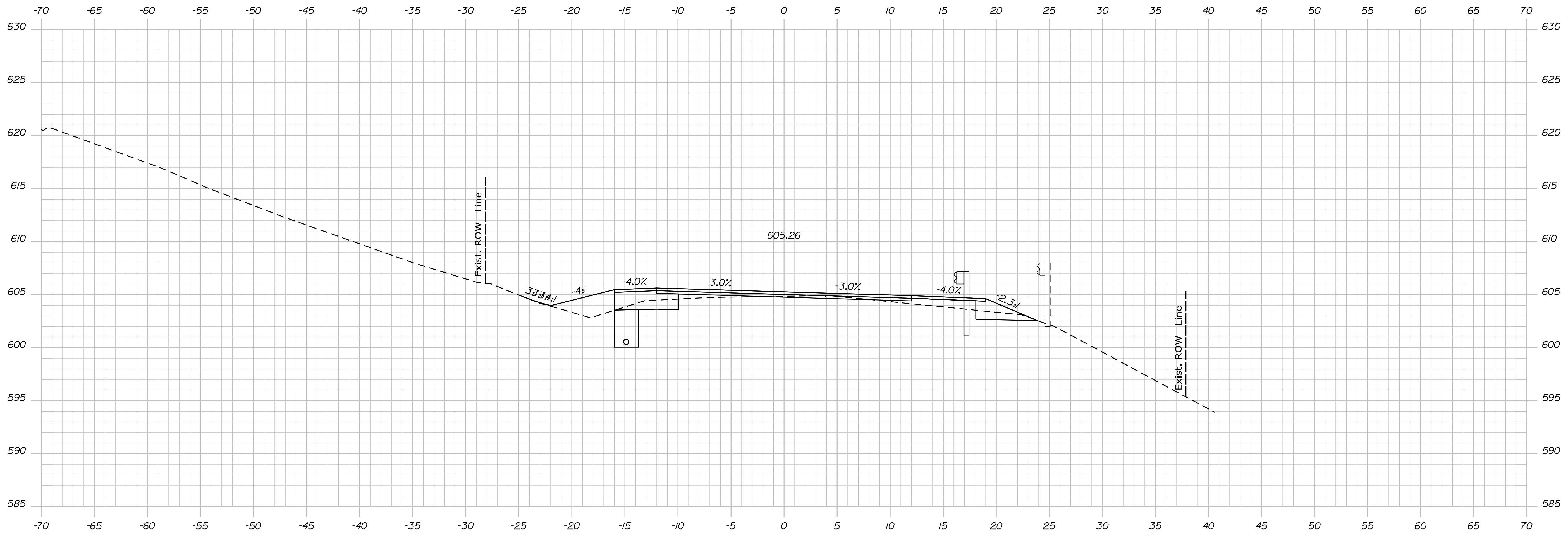

1113+50.00

Sta. 1113+50.00 to Sta. 1113+50.00

STATE OF MAINE
 DEPARTMENT OF TRANSPORTATION
STP-1824(500)

SIGNATURE
 P.E. NUMBER
 DATE

PROJ. MANAGER	BY	DATE
DESIGN DETAIL		
CHECKED/REVISED		
DESIGN DETAIL		
DESIGN DETAIL		
REVISIONS 1		
REVISIONS 2		
REVISIONS 3		
REVISIONS 4		
FIELD CHANGES		

**KINGFIELD
 ROUTE 16\27
 CROSS SECTIONS**

SHEET NUMBER
Xse
 OF 175

WIN 18245.00
HIERARCHIC PLANS

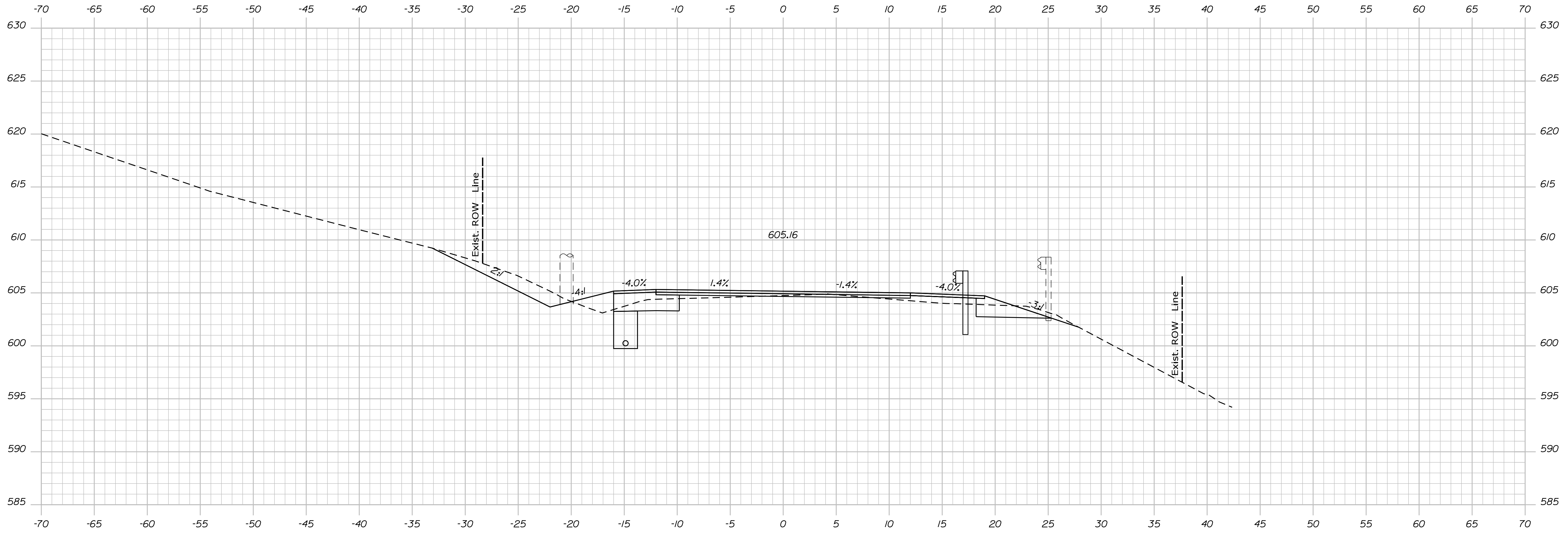

1114+00.00

Sta. 1114+00.00 to Sta. 1114+00.00

STATE OF MAINE
 DEPARTMENT OF TRANSPORTATION
STP-1824(500)

WIN
 18245.00
 HIERARCHIC PLANS

PROJ. MANAGER	BY	DATE
DESIGN DETAILER		
CHECKED/REVIEWED		
DESIGN DETAILER		
DESIGN DETAILER		
REVISIONS 1		
REVISIONS 2		
REVISIONS 3		
REVISIONS 4		
FIELD CHANGES		

**KINGFIELD
 ROUTE 16\27
 CROSS SECTIONS**

SHEET NUMBER
Xse
 OF 175

Date: \$date\$

Username:

Division: HIGHWAY

Filename: ... \Bentley\ustrn\Xsect.dgn

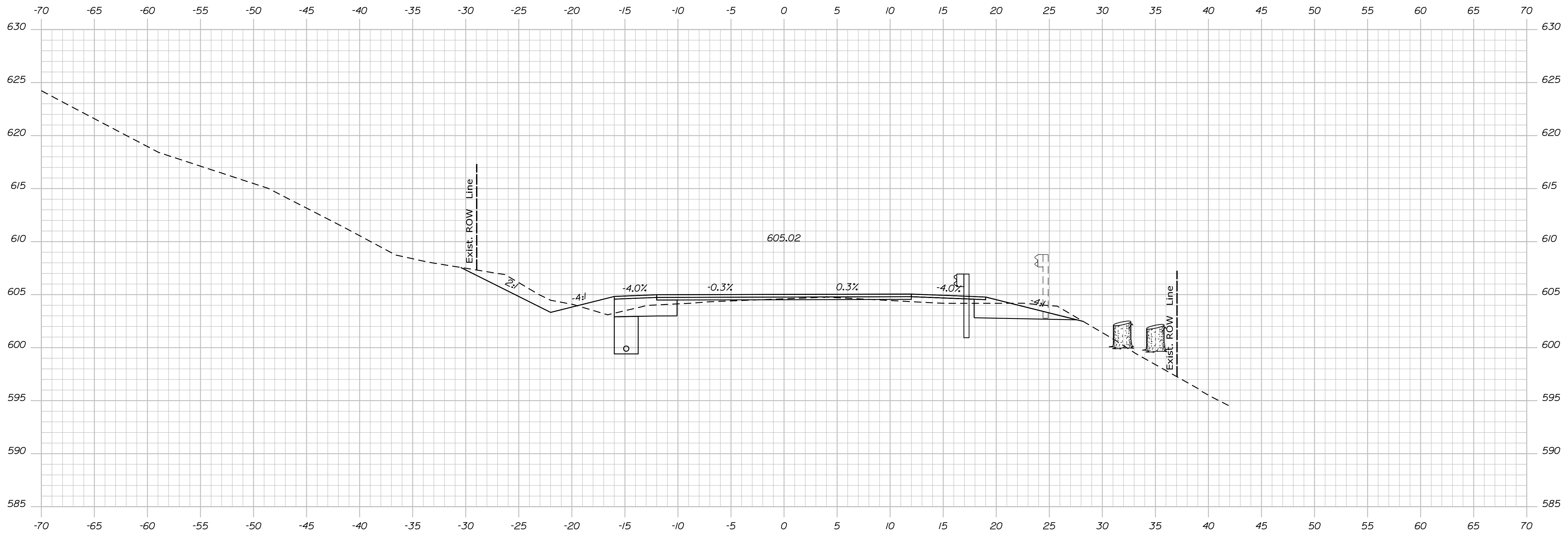

1114+50.00

Sta. 1114+50.00 to Sta. 1114+50.00

STATE OF MAINE
 DEPARTMENT OF TRANSPORTATION
STP-1824(500)

SIGNATURE
 P.E. NUMBER
 DATE

PROJ. MANAGER	DATE
DESIGN DETAIL	
CHECKED/REVISED	
DESIGN DETAIL	
DESIGN DETAIL	
REVISIONS 1	
REVISIONS 2	
REVISIONS 3	
REVISIONS 4	
FIELD CHANGES	

**KINGFIELD
 ROUTE 16\27
 CROSS SECTIONS**

SHEET NUMBER
Xse
 OF 175

WIN
 18245.00
 HIERARCHIC PLANS

Date: \$date\$

Username:

Division: HIGHWAY

Filename: ... \Bentley\ustrn\Xsect.dgn

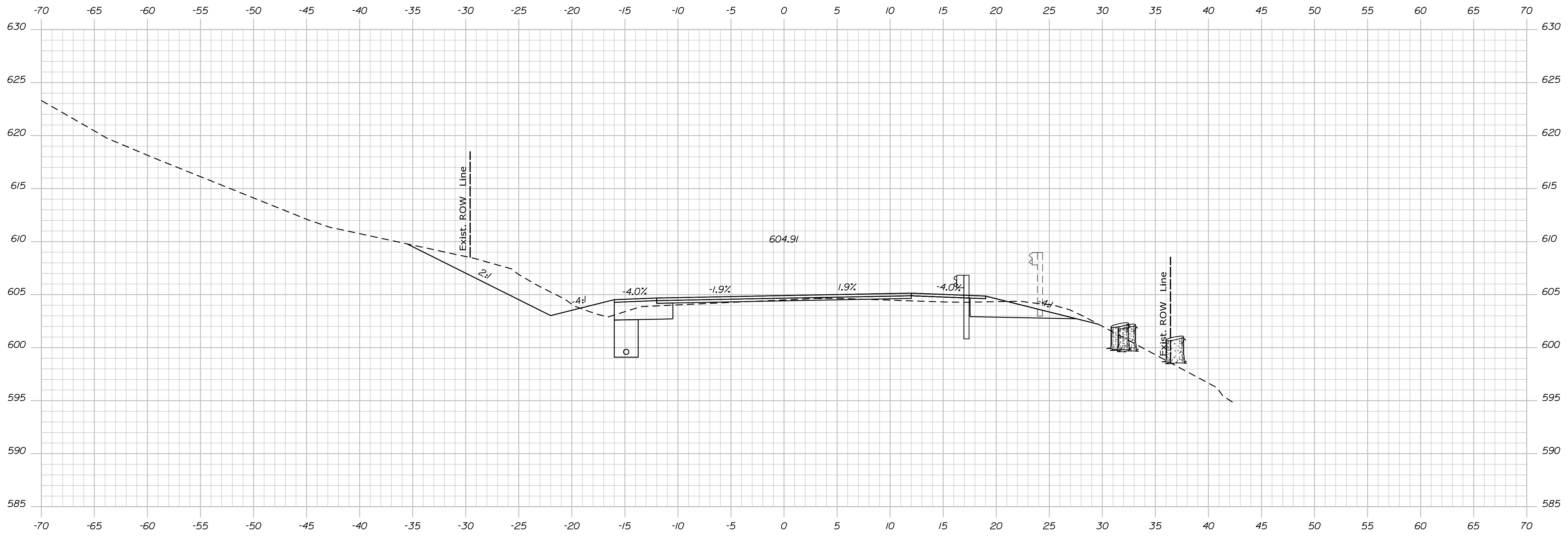

1115+00.00

Sta. 1115+00.00 to Sta. 1115+00.00

STATE OF MAINE
DEPARTMENT OF TRANSPORTATION
STP-1824(500)

SIGNATURE
P.E. NUMBER
DATE

PROJ. MANAGER	DATE
DESIGN DETAIL	
CHECKED/REVIEWED	
DESIGN DETAIL	
DESIGN DETAIL	
REVISIONS 1	
REVISIONS 2	
REVISIONS 3	
REVISIONS 4	
FIELD CHANGES	

**KINGFIELD
ROUTE 16\27
CROSS SECTIONS**

SHEET NUMBER
Xse
OF 175

WIN
18245.00
HIERARCHIC PLANS

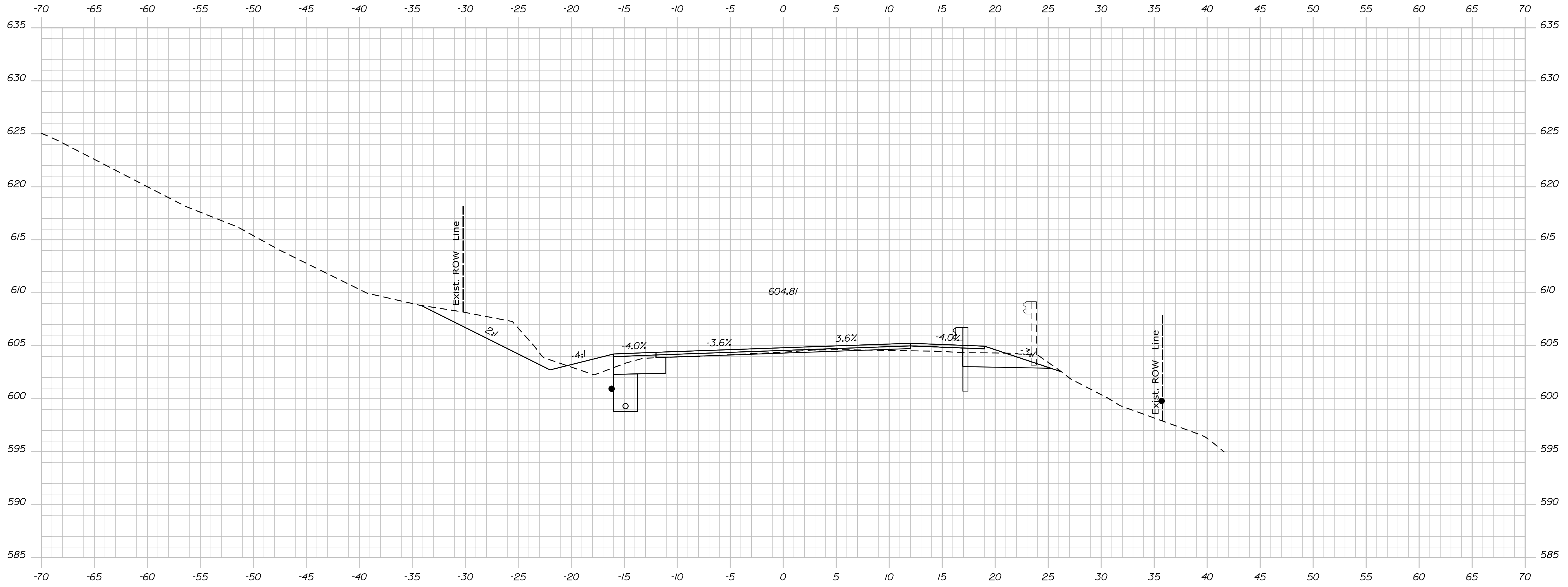

1115+50.00

STATE OF MAINE
DEPARTMENT OF TRANSPORTATION
STP-1824(500)

SIGNATURE
P.E. NUMBER
DATE

PROJ. MANAGER	DATE
DESIGN DETAIL	
CHECKED/REVIEWED	
DESIGN DETAIL	
DESIGN DETAIL	
REVISIONS 1	
REVISIONS 2	
REVISIONS 3	
REVISIONS 4	
FIELD CHANGES	

KINGFIELD
ROUTE 16\27
CROSS SECTIONS

SHEET NUMBER
Xse
OF 175

WIN
18245.00
HIERARCHY PLANS

Date: \$date\$

Username:

Division: HIGHWAY

Filename: ... \Bentley\ustrn\Xsect.dgn

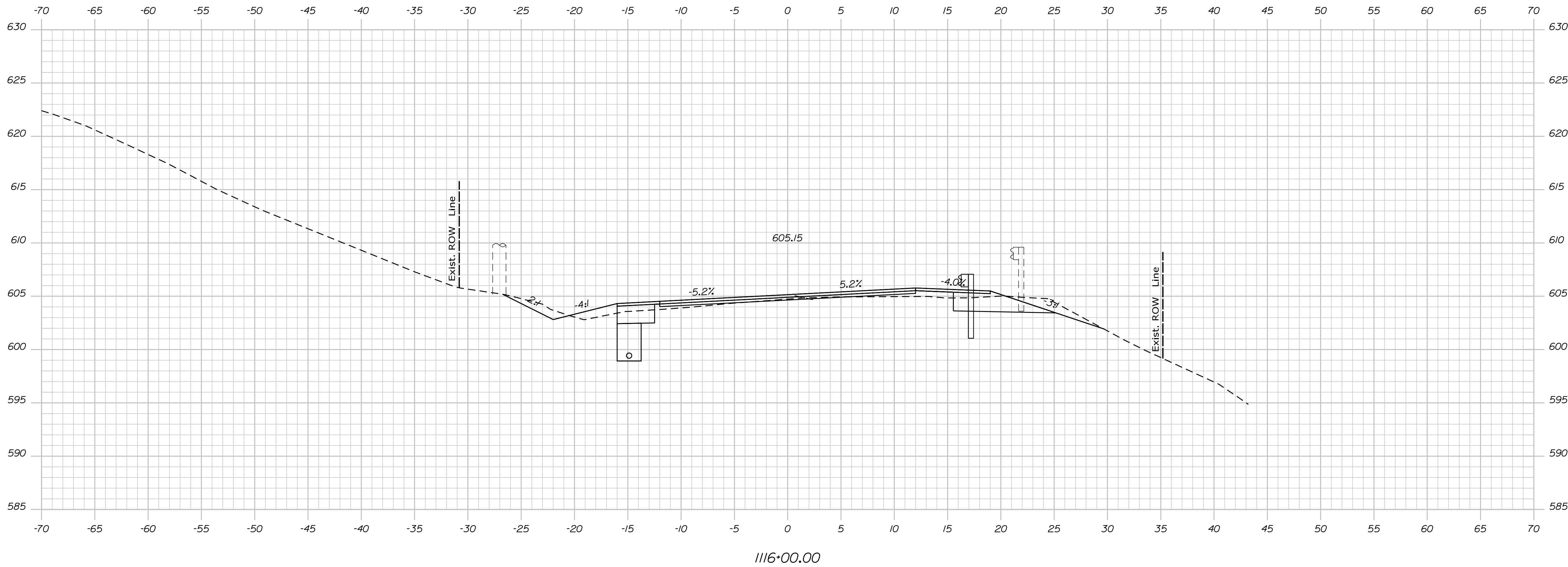
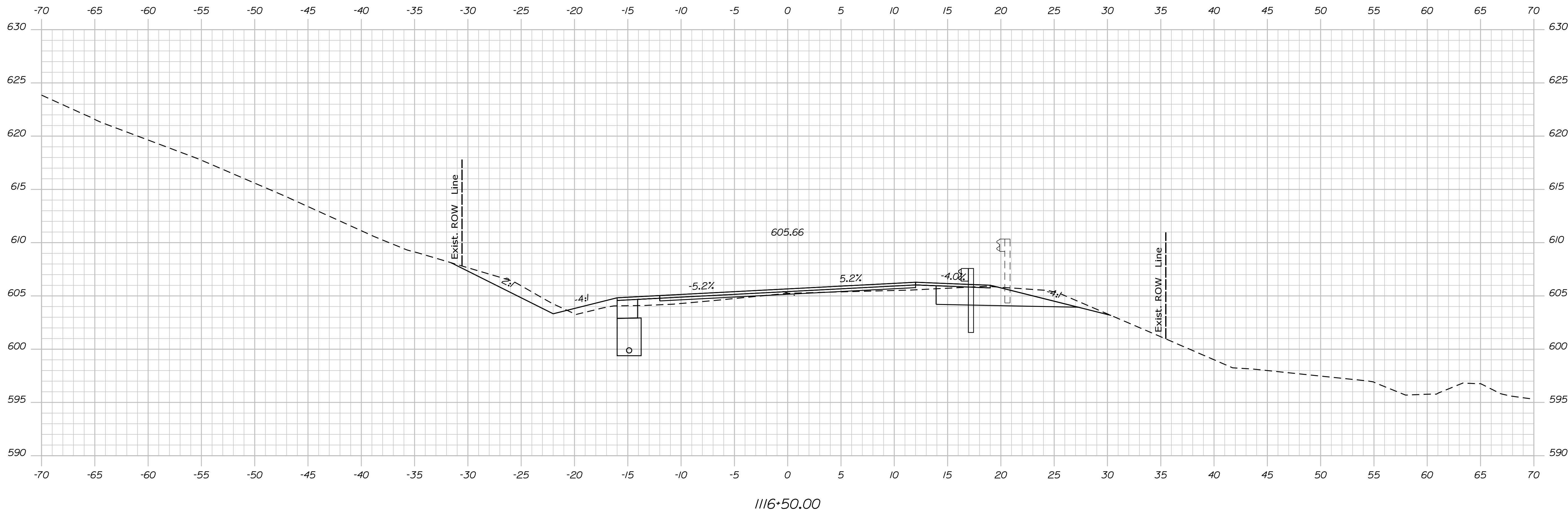

STATE OF MAINE
DEPARTMENT OF TRANSPORTATION
STP-1824(500)
WIN
18245.00
HIGHWAY PLANS

SIGNATURE
P.E. NUMBER
DATE

PROJ. MANAGER	DATE
DESIGN DETAIL	
CHECKED/REVIEWED	
DESIGN DETAIL	
DESIGN DETAIL	
REVISIONS 1	
REVISIONS 2	
REVISIONS 3	
REVISIONS 4	
FIELD CHANGES	

KINGFIELD
ROUTE 16\27
CROSS SECTIONS

SHEET NUMBER
Xse
OF 175

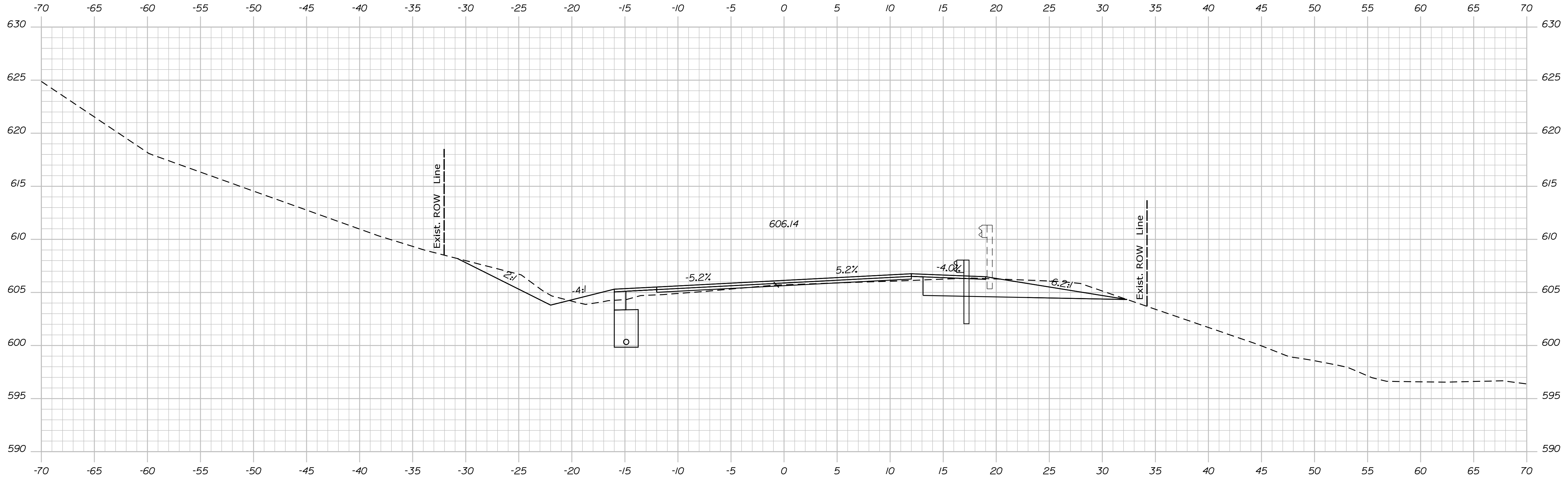

1117+00.00

STATE OF MAINE
 DEPARTMENT OF TRANSPORTATION
STP-1824(500)

PROJ. MANAGER	DATE
CHECKED/REVIEWED	BY
DESIGN DETAILED	DATE
DESIGN DETAILED	SIGNATURE
REVISIONS 1	P.E. NUMBER
REVISIONS 2	DATE
REVISIONS 3	
REVISIONS 4	
FIELD CHANGES	

WIN
 18245.00
 HIERARCHIC PLANS

**KINGFIELD
 ROUTE 16\27
 CROSS SECTIONS**

SHEET NUMBER
Xse
 OF 175

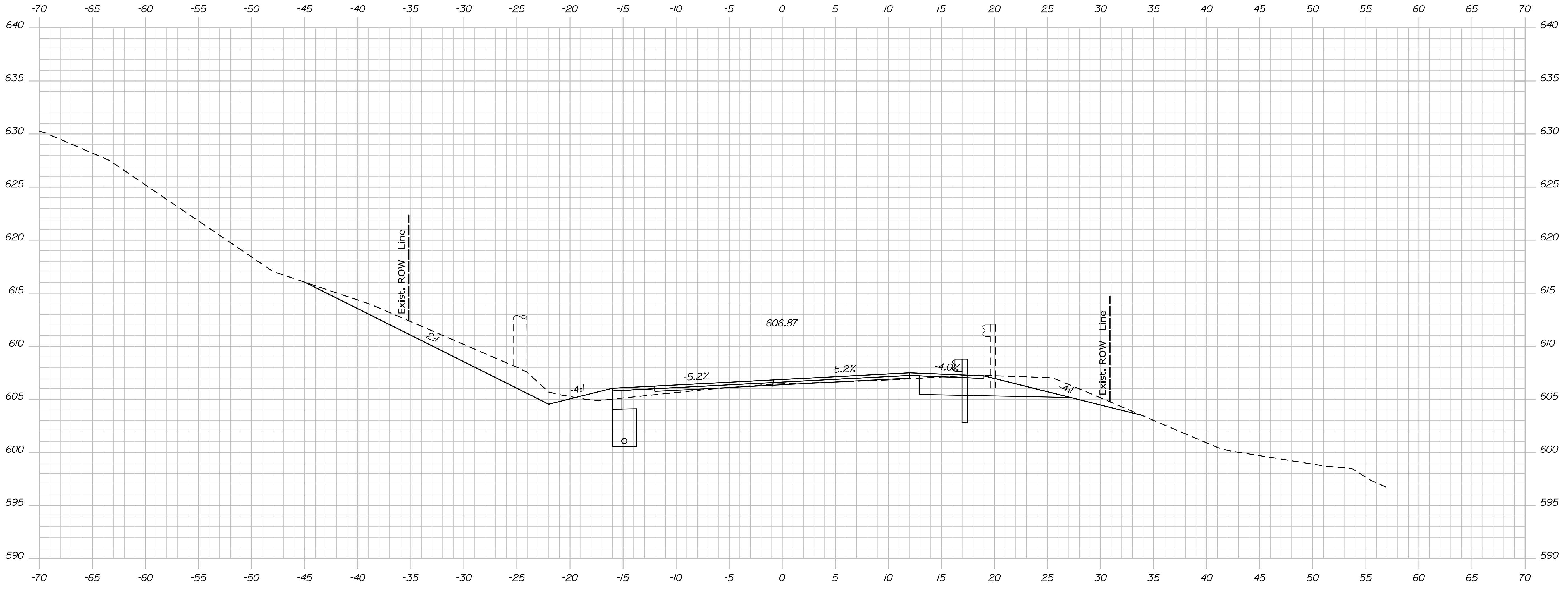

1117+50.00

STATE OF MAINE
 DEPARTMENT OF TRANSPORTATION
STP-1824(500)

SIGNATURE
 P.E. NUMBER
 DATE

PROJ. MANAGER	DATE
DESIGN DETAILER	
CHECKED/REVIEWED	
DESIGN DETAILER	
DESIGN DETAILER	
REVISIONS 1	
REVISIONS 2	
REVISIONS 3	
REVISIONS 4	
FIELD CHANGES	

**KINGFIELD
 ROUTE 16\27
 CROSS SECTIONS**

SHEET NUMBER
Xse
 OF 175

WIN
 18245.00
 HIERARCHY PLANS

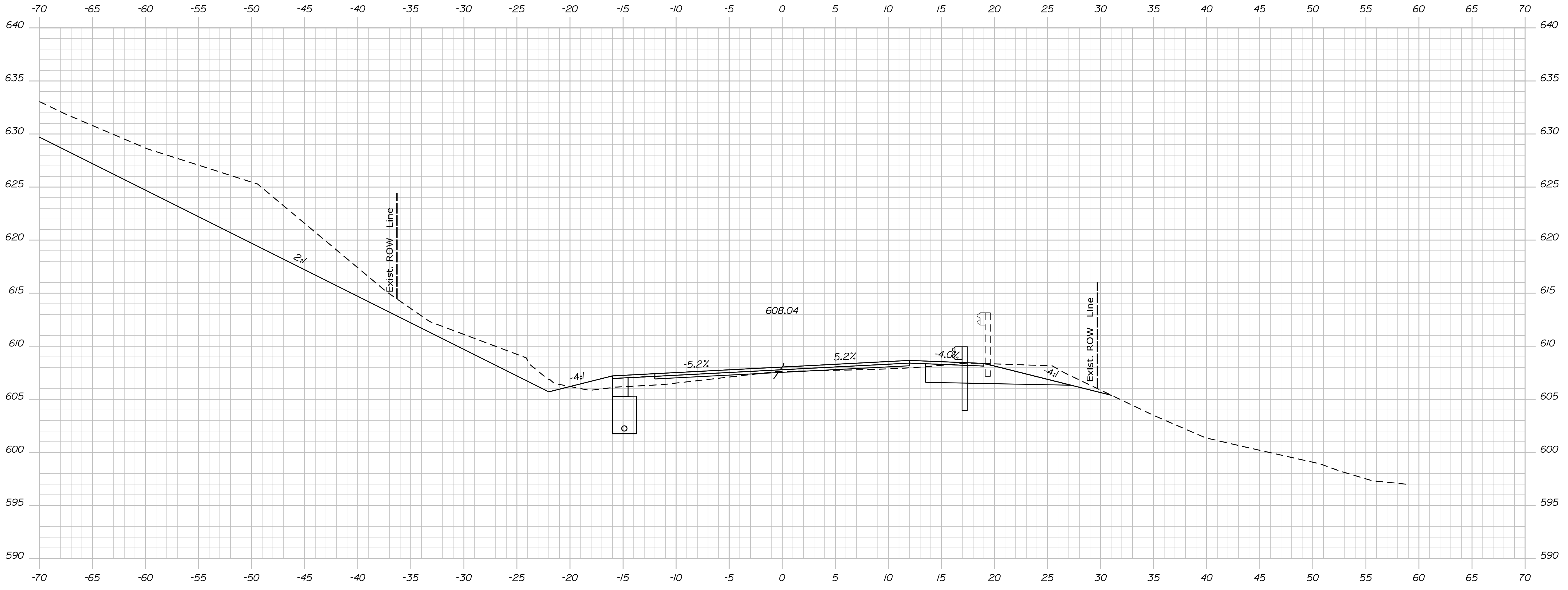

1118+00.00

STATE OF MAINE
DEPARTMENT OF TRANSPORTATION
STP-1824(500)

WIN
18245.00
HIERARCHIC PLANS

PROJ. MANAGER	DATE
DESIGN DETAILED	
CHECKED/REVIEWED	
DESIGN DETAILED	
DESIGN DETAILED	
REVISIONS 1	
REVISIONS 2	
REVISIONS 3	
REVISIONS 4	
FIELD CHANGES	

KINGFIELD
ROUTE 16\27
CROSS SECTIONS

SHEET NUMBER
Xse
OF 175

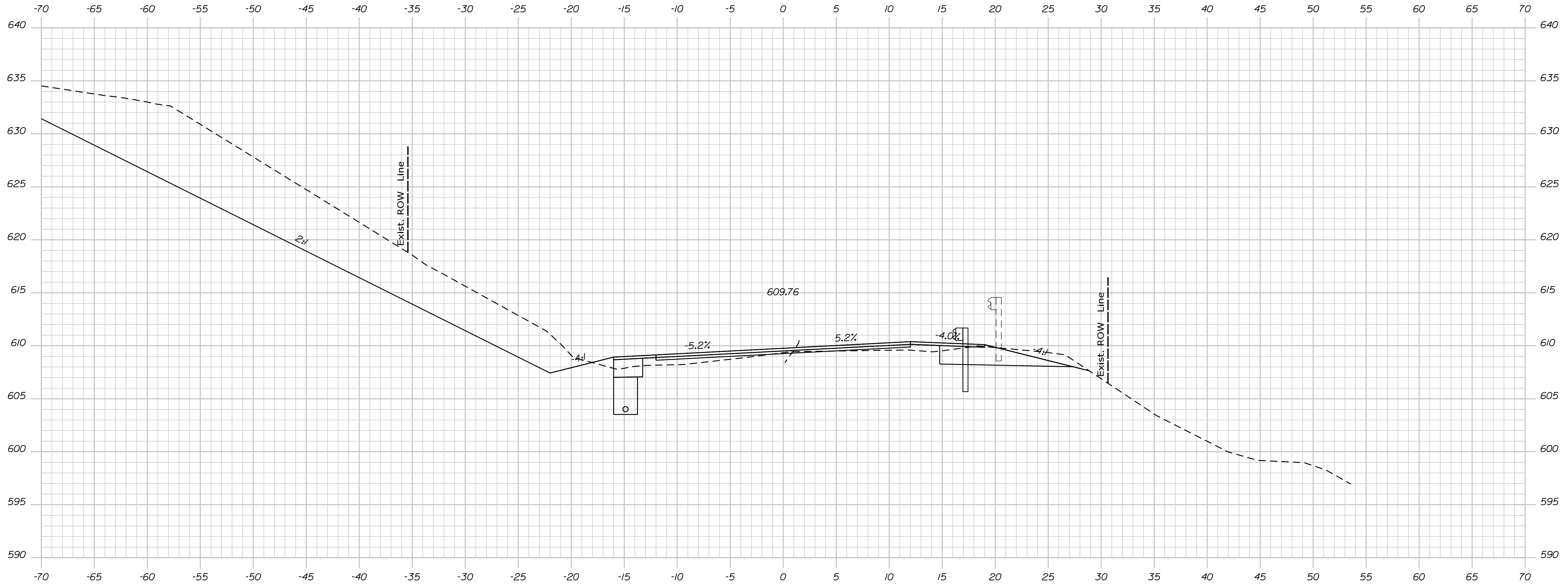

1118+50.00

Sta. 1118+50.00 to Sta. 1118+50.00

STATE OF MAINE
 DEPARTMENT OF TRANSPORTATION
STP-1824(500)

WIN
 18245.00
 HIERARCHIC PLANS

PROJ. MANAGER	DATE
DESIGN DETAILED	
CHECKED/REVIEWED	
DESIGN DETAILED	
DESIGN DETAILED	
REVISIONS 1	
REVISIONS 2	
REVISIONS 3	
REVISIONS 4	
FIELD CHANGES	

KINGFIELD
 ROUTE 16\27
 CROSS SECTIONS

SHEET NUMBER
Xse
 OF 175

Date: \$date\$

Username:

Division: HIGHWAY

Filename: ... \Bentley\ustrn\Xsect.dgn

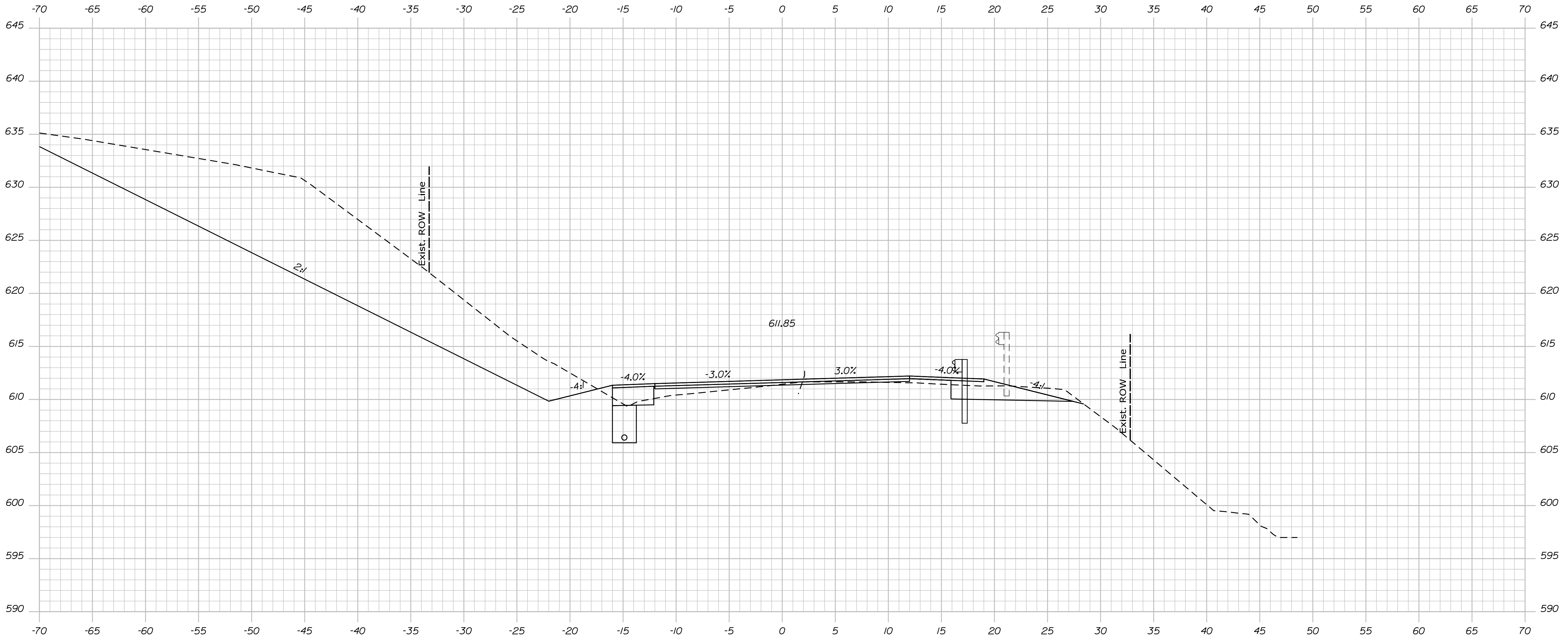

1119+00.00

Sta. 1119+00.00 to Sta. 1119+00.00

STATE OF MAINE
 DEPARTMENT OF TRANSPORTATION
STP-1824(500)

SIGNATURE
 P.E. NUMBER
 DATE

PROJ. MANAGER	DATE
DESIGN/DETAILED	
CHECKED/REVIEWED	
DESIGN/DETAILED	
DESIGN/DETAILED	
REVISIONS 1	
REVISIONS 2	
REVISIONS 3	
REVISIONS 4	
FIELD CHANGES	

KINGFIELD
 ROUTE 16\27
 CROSS SECTIONS

SHEET NUMBER
Xse
 OF 175

WIN
 18245.00
 HIERARCHIC PLANS

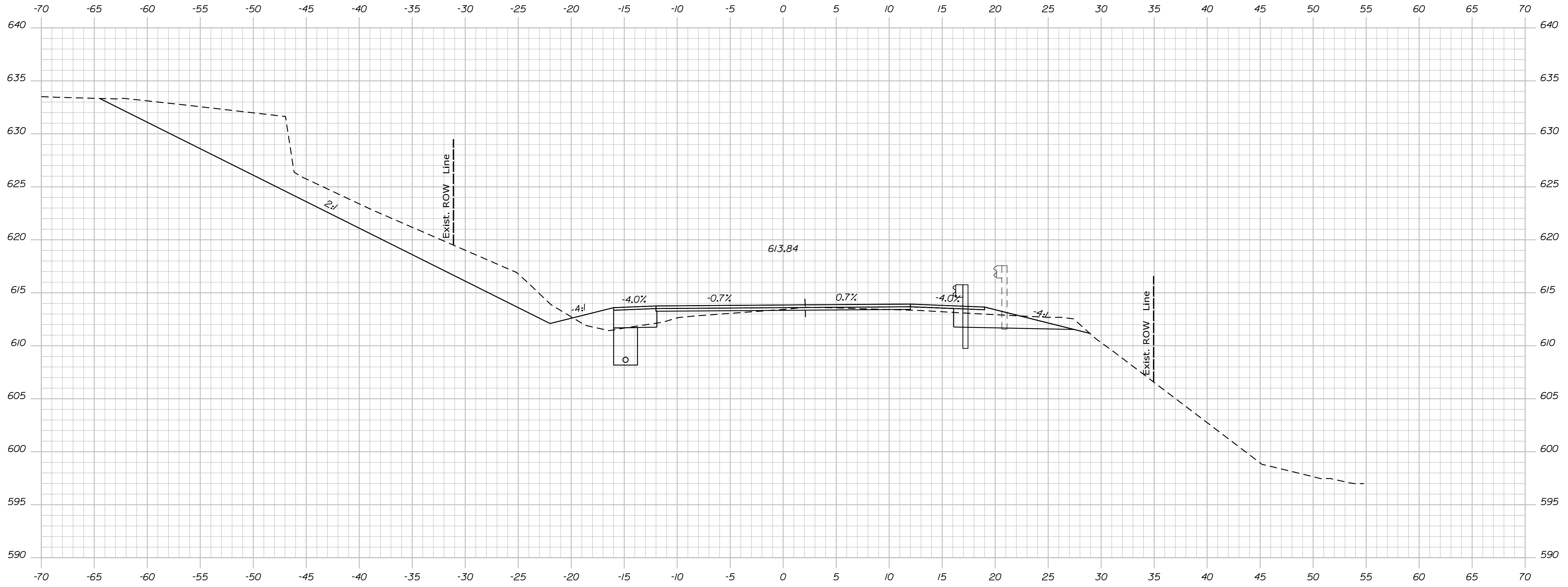

1119+50.00

Sta. 1119+50.00 to Sta. 1119+50.00

STATE OF MAINE
 DEPARTMENT OF TRANSPORTATION
STP-1824(500)

WIN
 18245.00
 HIERARCHIC PLANS

PROJ. MANAGER	DATE
DESIGN DETAILED	
CHECKED/REVIEWED	
DESIGN DETAILED	
DESIGN DETAILED	
REVISIONS 1	
REVISIONS 2	
REVISIONS 3	
REVISIONS 4	
FIELD CHANGES	

KINGFIELD
 ROUTE 16\27
 CROSS SECTIONS

SHEET NUMBER
Xse
 OF 175

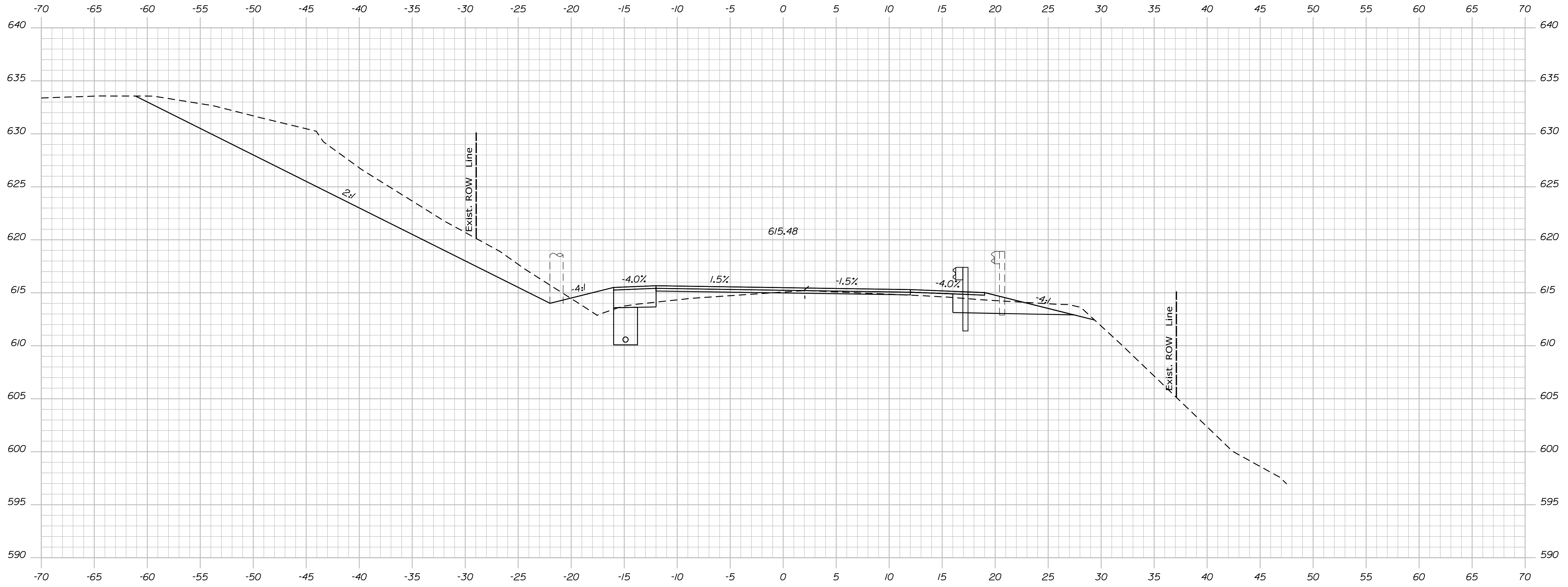

1120+00.00

STATE OF MAINE
 DEPARTMENT OF TRANSPORTATION
STP-1824(500)

WIN
 18245.00
 HIERARCHIC PLANS

PROJ. MANAGER	DATE
DESIGN DETAILED	
CHECKED/REVIEWED	
DESIGN DETAILED	
DESIGN DETAILED	
REVISIONS 1	
REVISIONS 2	
REVISIONS 3	
REVISIONS 4	
FIELD CHANGES	

KINGFIELD
 ROUTE 16\27
 CROSS SECTIONS

SHEET NUMBER
Xse
 OF 175

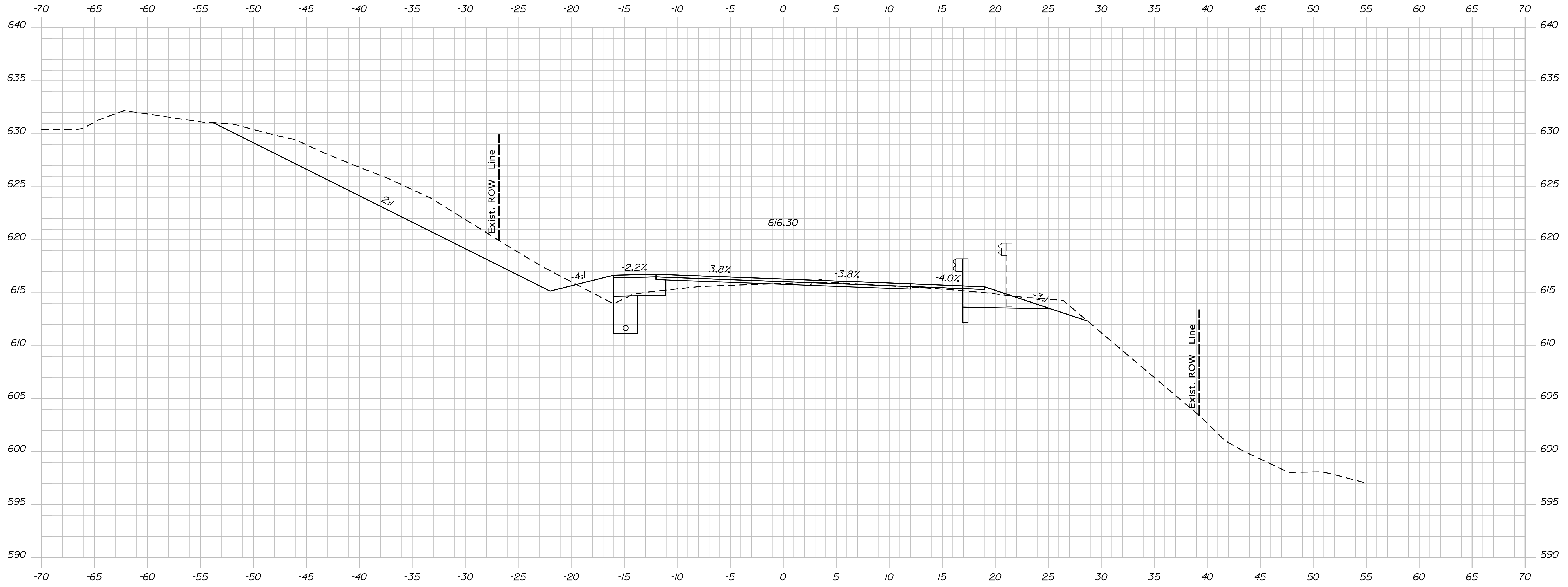

1120+50.00

STATE OF MAINE
 DEPARTMENT OF TRANSPORTATION
STP-1824(500)

WIN
 18245.00
 HIERARCHIC PLANS

PROJ. MANAGER	DATE
DESIGN DETAIL	
CHECKED/REVIEWED	
DESIGN DETAIL	
DESIGN DETAIL	
REVISIONS 1	
REVISIONS 2	
REVISIONS 3	
REVISIONS 4	
FIELD CHANGES	

KINGFIELD
 ROUTE 16\27
 CROSS SECTIONS

SHEET NUMBER
Xse
 OF 175

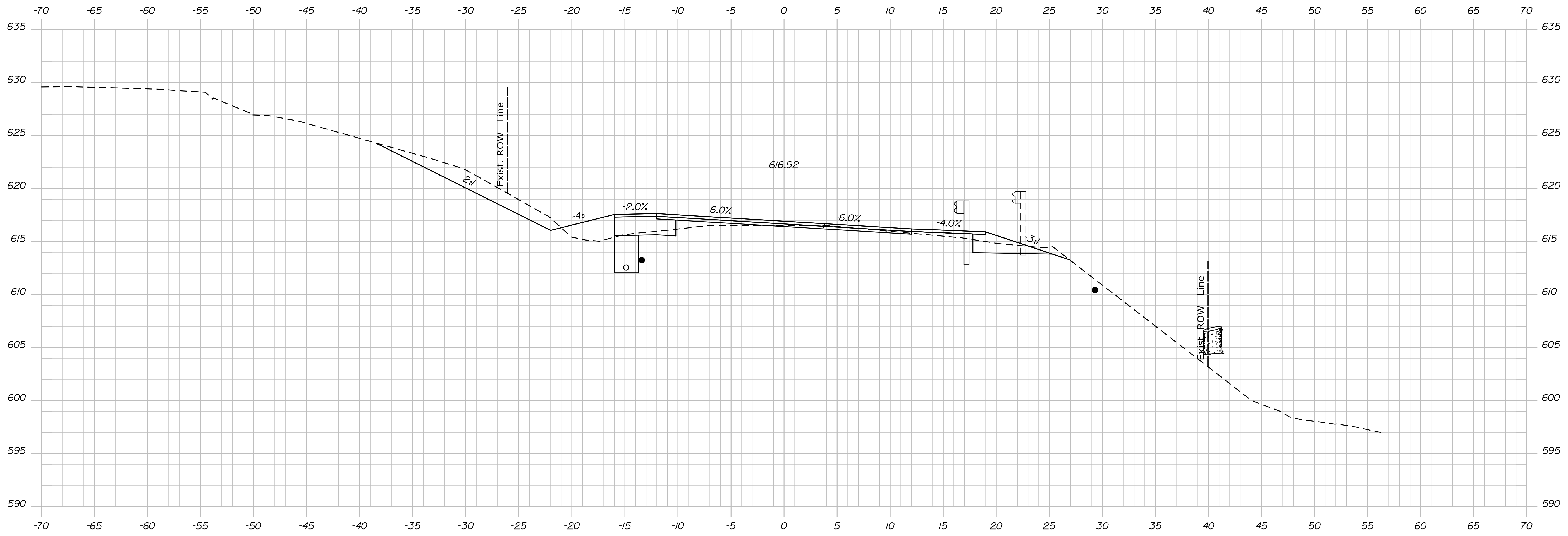

1121+00.00

Sta. 1121+00.00 to Sta. 1121+00.00

STATE OF MAINE
 DEPARTMENT OF TRANSPORTATION
STP-1824(500)

WIN
 18245.00
 HIERARCHIC PLANS

PROJ. MANAGER	BY	DATE
DESIGN DETAILED		
CHECKED/REVIEWED		
DESIGN DETAILED		
DESIGN DETAILED		
REVISIONS 1		
REVISIONS 2		
REVISIONS 3		
REVISIONS 4		
FIELD CHANGES		

KINGFIELD
 ROUTE 16\27
 CROSS SECTIONS

SHEET NUMBER
Xse
 OF 175

Date: \$date\$

Username:

Division: HIGHWAY

Filename: ... \Bentley\ustrn\Xsect.dgn

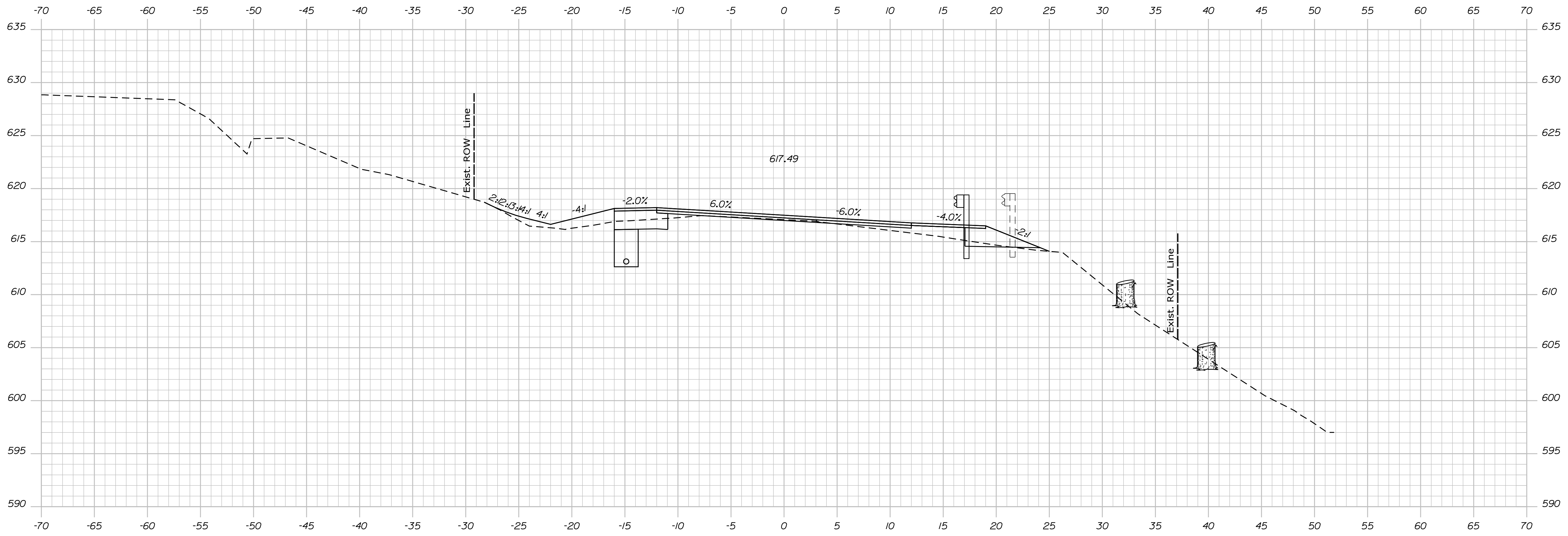

STATE OF MAINE
DEPARTMENT OF TRANSPORTATION
STP-1824(500)

WIN
18245.00
HIERARCHIC PLANS

PROJ. MANAGER	DATE
DESIGN/DETAILED	
CHECKED/REVIEWED	
DESIGN/DETAILED	
DESIGN/DETAILED	
REVISIONS 1	
REVISIONS 2	
REVISIONS 3	
REVISIONS 4	
FIELD CHANGES	

KINGFIELD
ROUTE 16\27
CROSS SECTIONS

SHEET NUMBER
Xse
OF 175

Date: \$date\$

Username:

Division: HIGHWAY

Filename: ... \Bentley\ustrn\Xsect.dgn

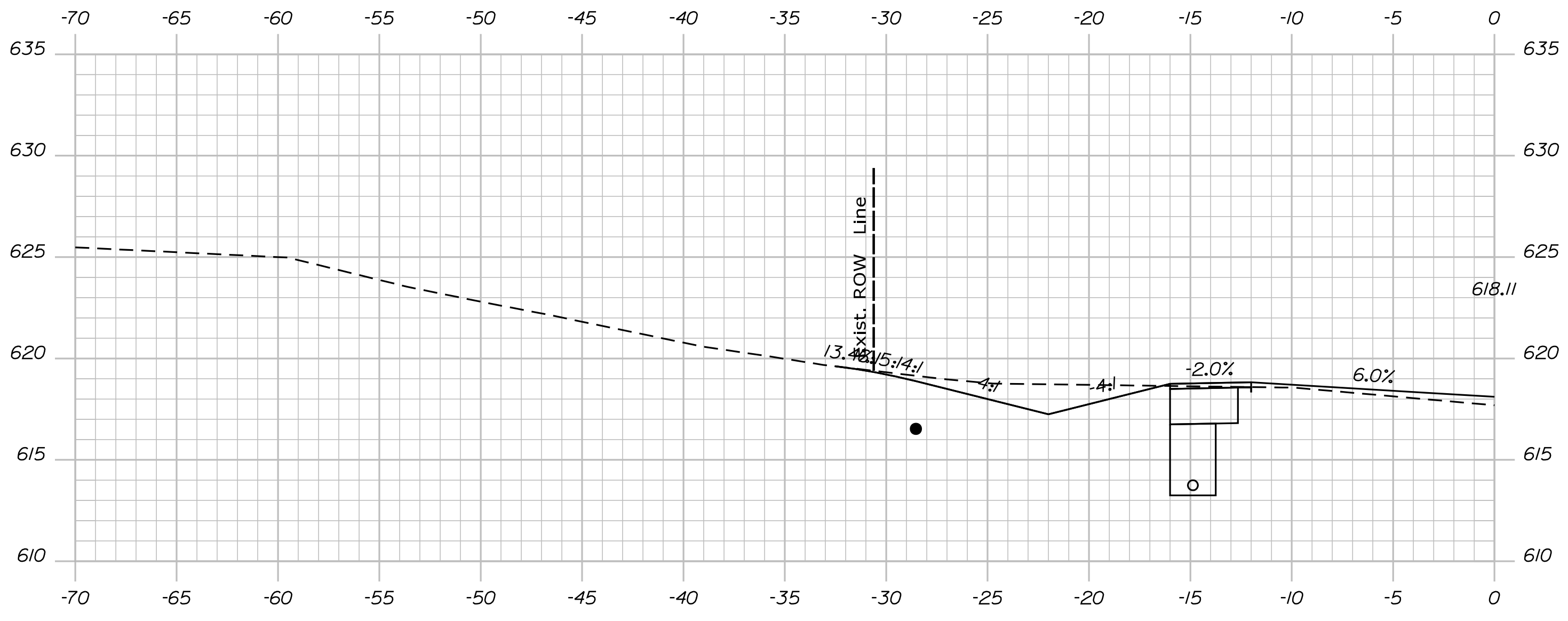

1122+42.00

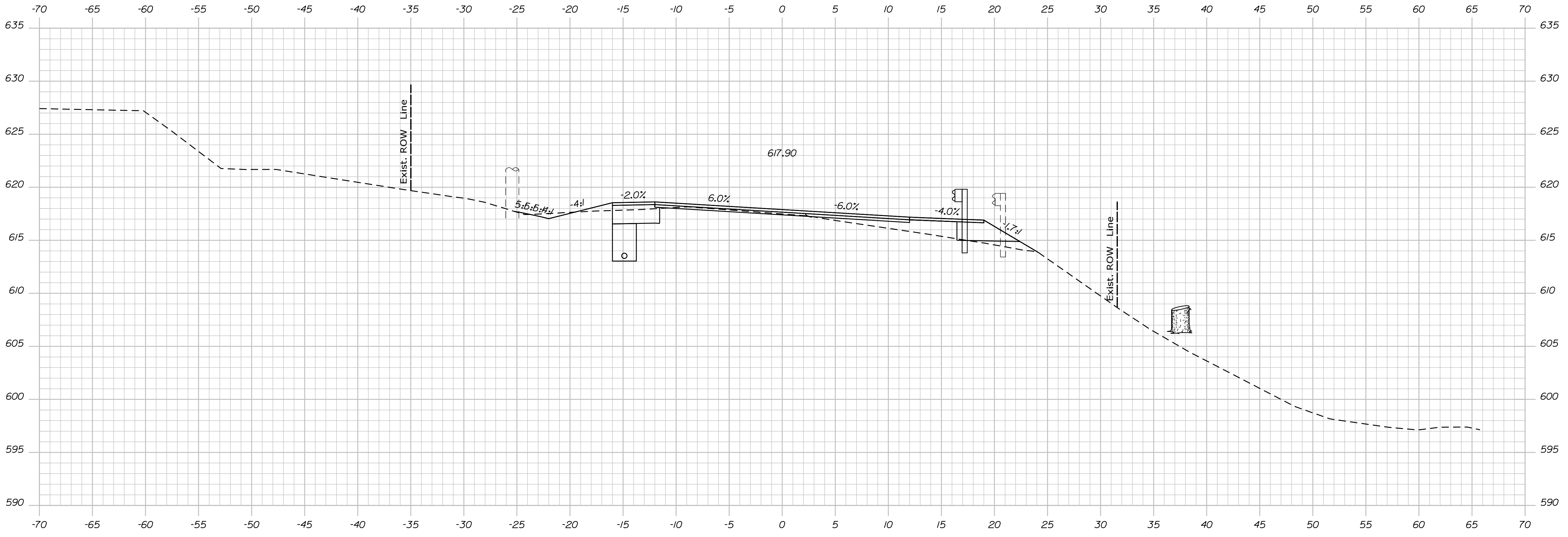

1122+00.00

STATE OF MAINE
DEPARTMENT OF TRANSPORTATION
STP-1824(500)
WIN
18245.00
HIERARCHIC PLANS

SIGNATURE
P.E. NUMBER
DATE

PROJ. MANAGER	DATE
DESIGN DETAILED	
CHECKED/REVIEWED	
DESIGN DETAILED	
DESIGN DETAILED	
REVISIONS 1	
REVISIONS 2	
REVISIONS 3	
REVISIONS 4	
FIELD CHANGES	

KINGFIELD
ROUTE 16\27
CROSS SECTIONS

SHEET NUMBER
Xse
OF 175

Date: \$date\$

Username:

Division: HIGHWAY

Filename: ... \Bentley\ustrn\Xsect.dgn

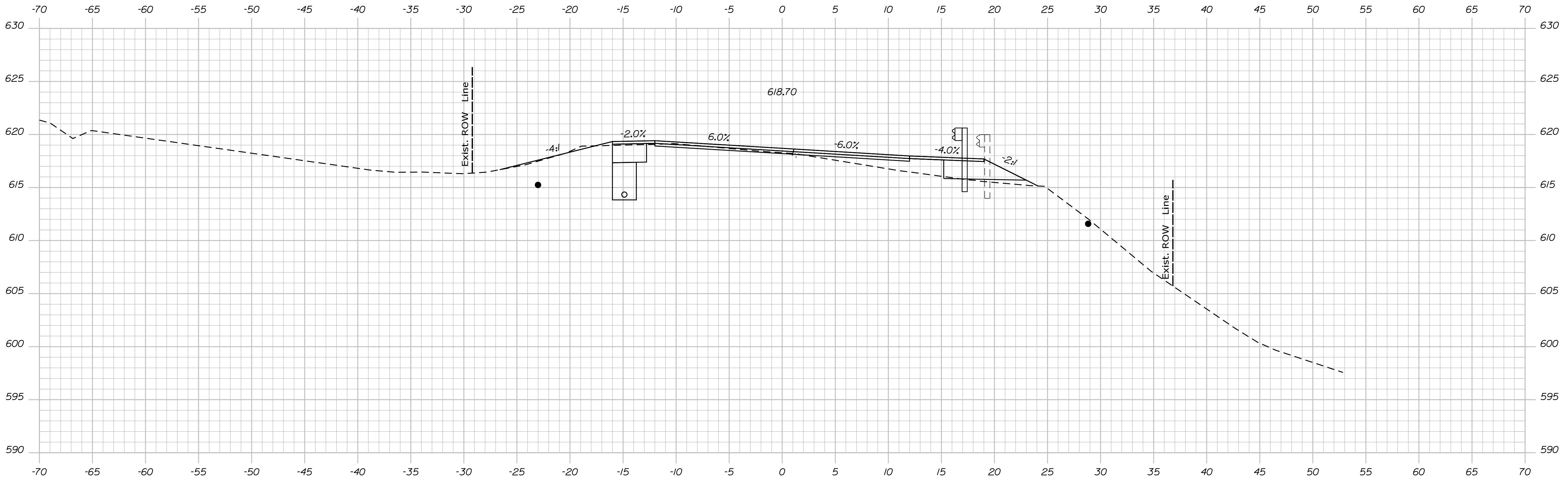

1123+00.00

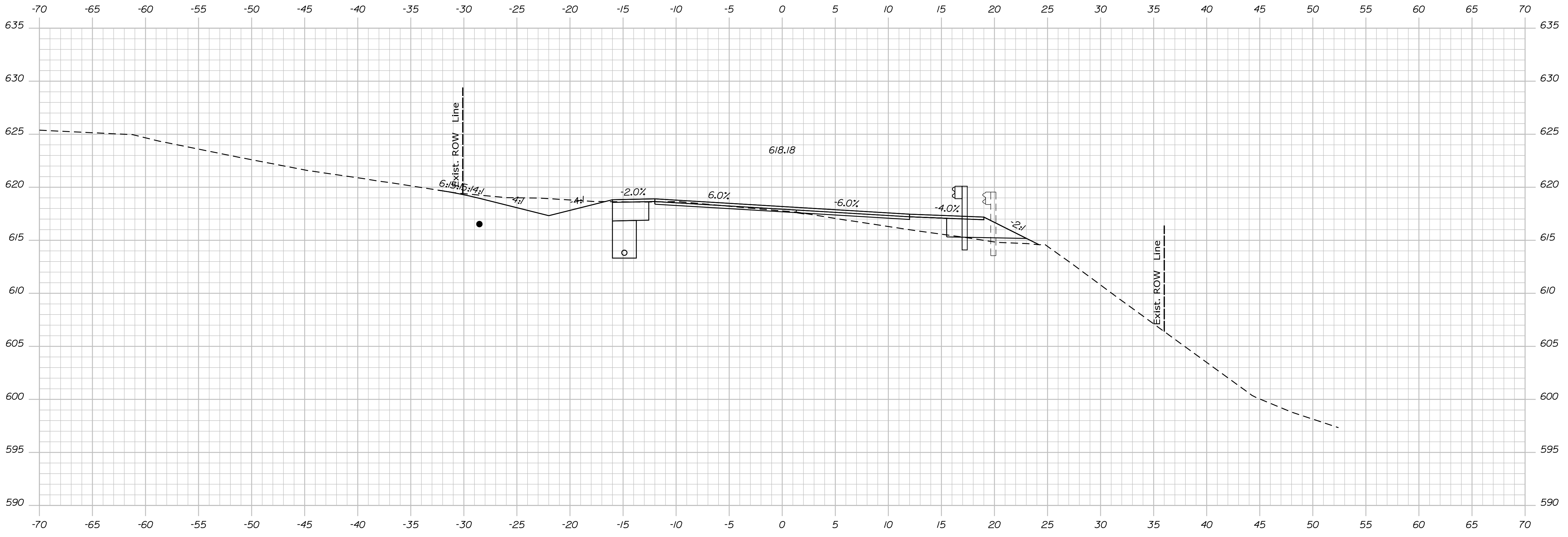

1122+50.00

STATE OF MAINE
 DEPARTMENT OF TRANSPORTATION
 STP-1824(500)
 WIN
 18245.00
 HIGHWAY PLANS

SIGNATURE
 P.E. NUMBER
 DATE

PROJ. MANAGER	DATE
DESIGN DETAILER	
CHECKED/REVIEWED	
DESIGN DETAILER	
DESIGN DETAILER	
REVISIONS 1	
REVISIONS 2	
REVISIONS 3	
REVISIONS 4	
FIELD CHANGES	

KINGFIELD
 ROUTE 16\27
 CROSS SECTIONS

SHEET NUMBER
Xse
 OF 175

Date: \$date\$

Username:

Division: HIGHWAY

Filename: ... \Bentley\ustrn\Xsect.dgn

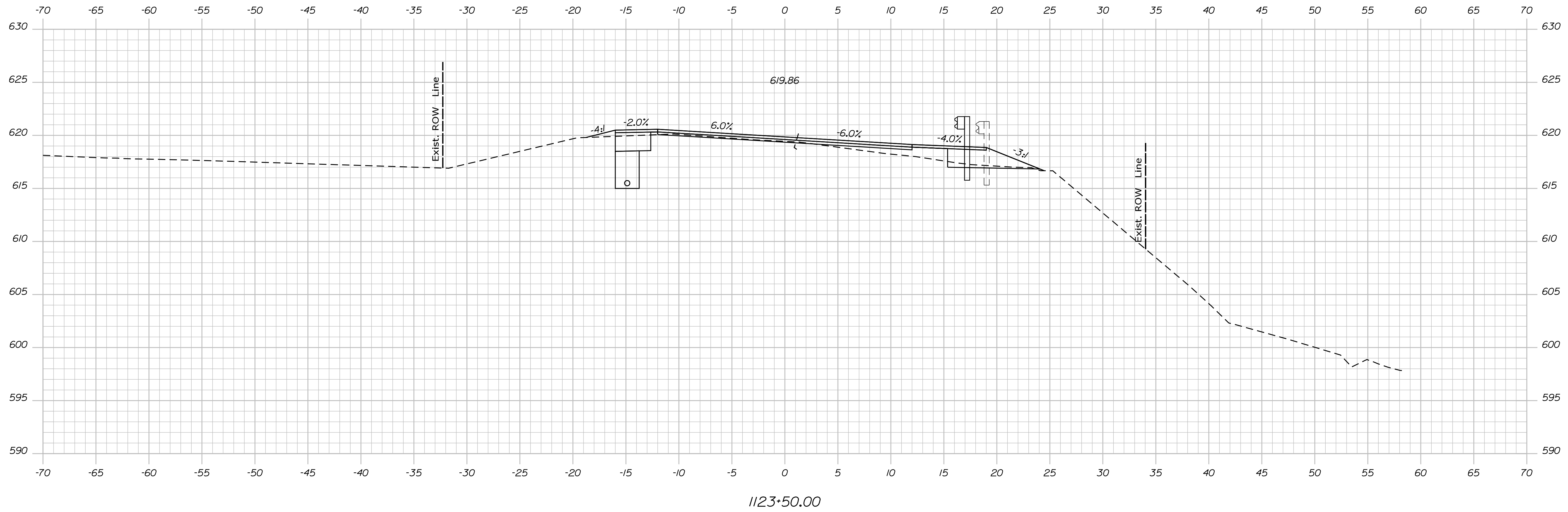
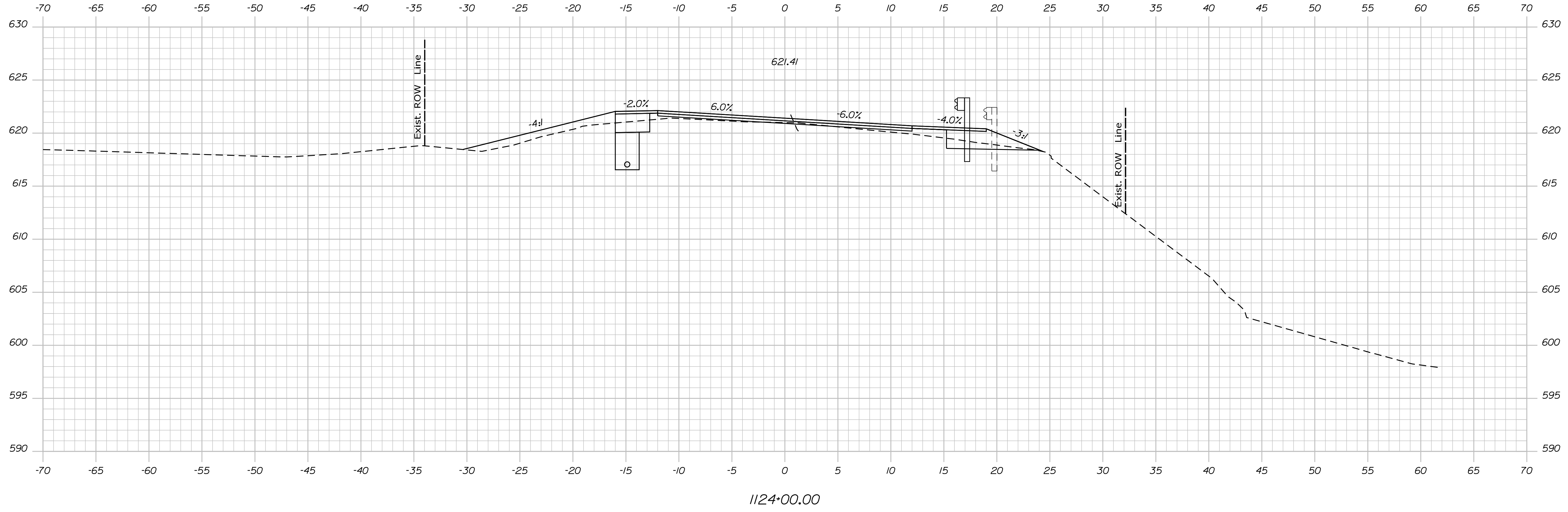

STATE OF MAINE
DEPARTMENT OF TRANSPORTATION
STP-1824(500)

WIN
18245.00
HIERARCHIC PLANS

PROJ. MANAGER	BY	DATE

KINGFIELD
ROUTE 16\27
CROSS SECTIONS

SHEET NUMBER
Xse
OF 175

Date: \$date\$

Username:

Division: HIGHWAY

Filename: ... \Bentley\ustrn\Xsect.dgn

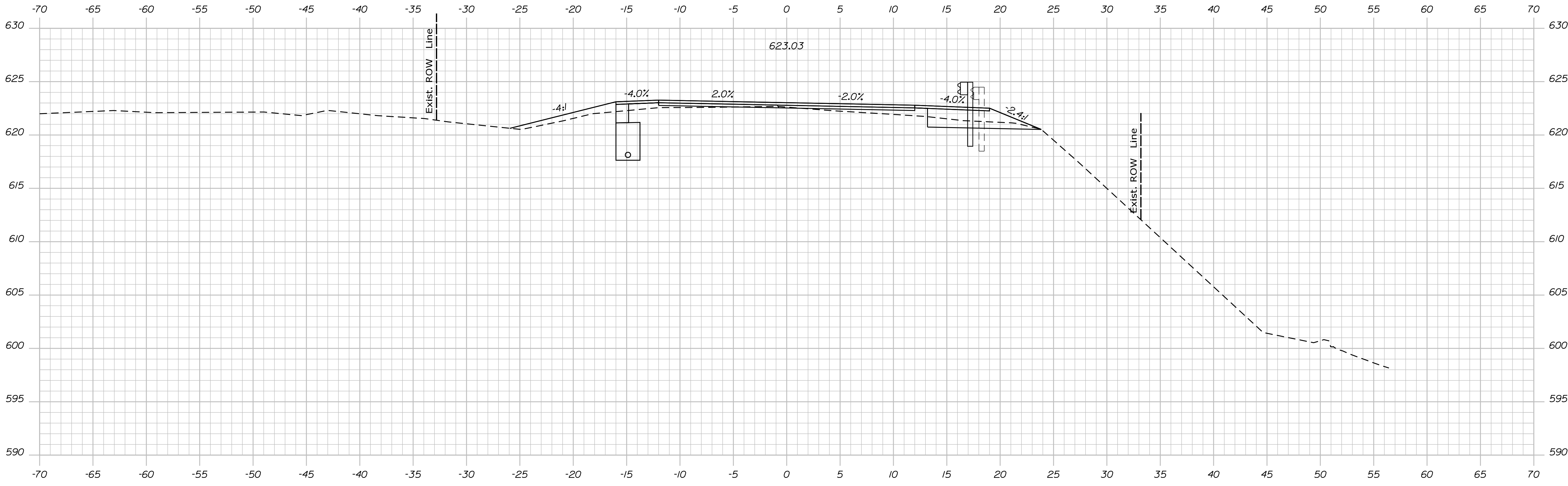

1125+00.00

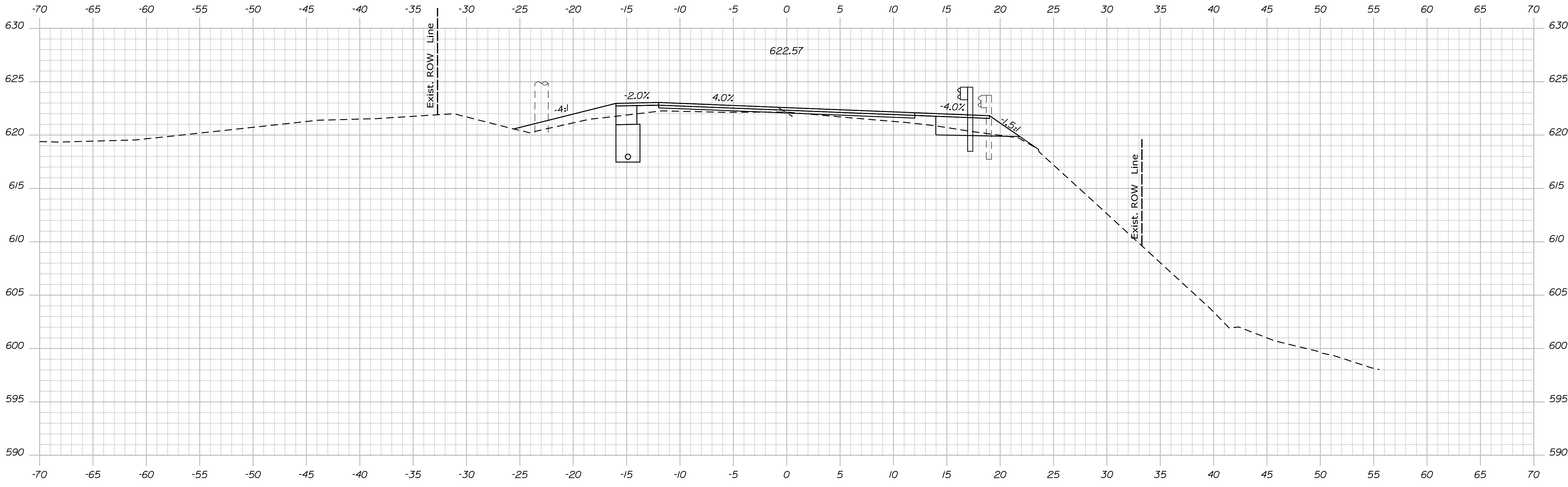

1124+50.00

STATE OF MAINE
 DEPARTMENT OF TRANSPORTATION
STP-1824(500)
 WIN
 18245.00
 HIGHWAY PLANS

SIGNATURE	DATE
P.E. NUMBER	DATE

PROJ. MANAGER	DATE
CHECKED/REVIEWED	
DESIGN DETAILED	
DESIGN DETAILED	
REVISIONS 1	
REVISIONS 2	
REVISIONS 3	
REVISIONS 4	
FIELD CHANGES	

KINGFIELD
 ROUTE 16\27
 CROSS SECTIONS

SHEET NUMBER
Xse
 OF 175

Date: \$date\$

Username:

Division: HIGHWAY

Filename: ... \Bentley\ustrn\Xsect.dgn

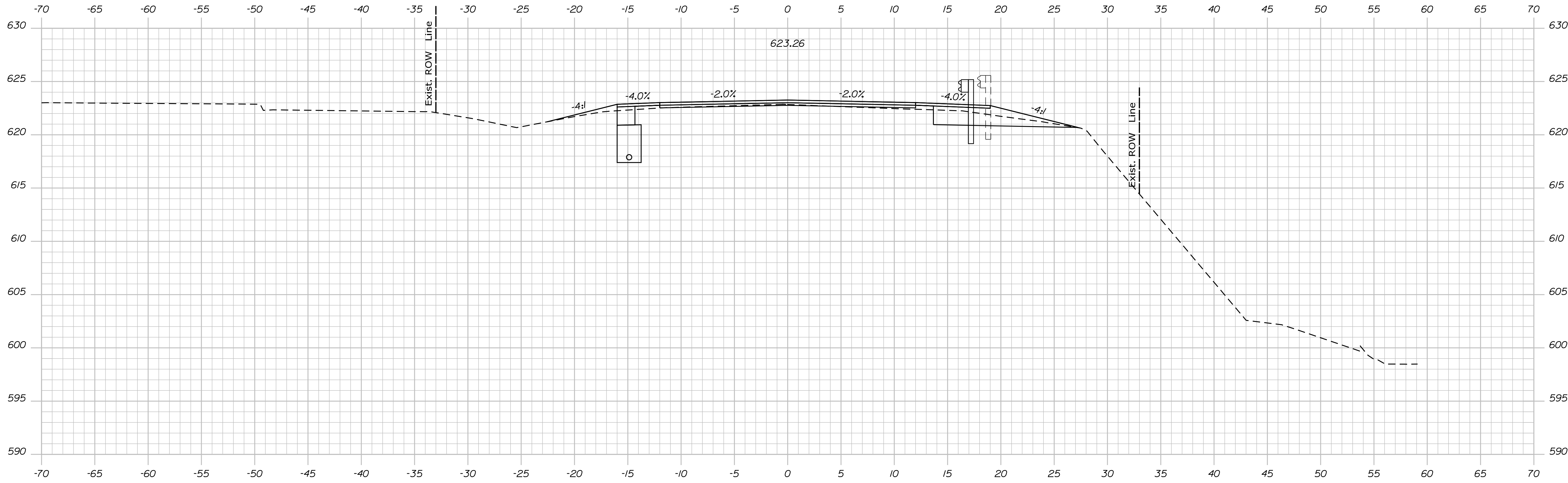

1126+00.00

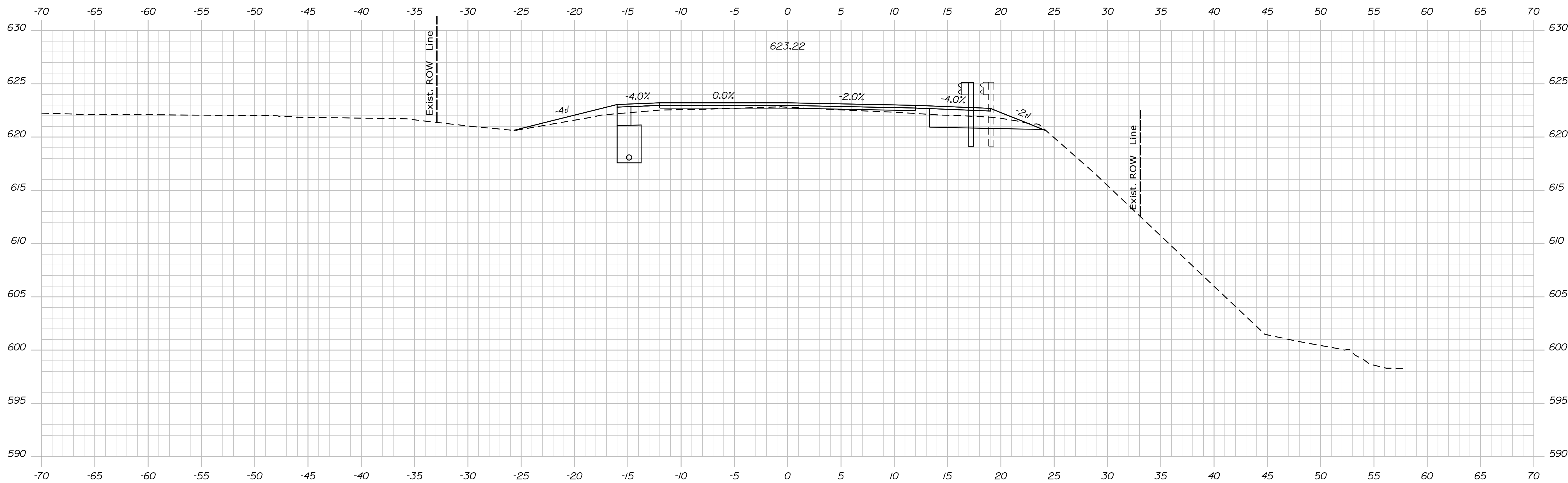

1125+50.00

STATE OF MAINE
 DEPARTMENT OF TRANSPORTATION
STP-1824(500)
 WIN
 18245.00
 HIGHWAY PLANS

SIGNATURE
 P.E. NUMBER
 DATE

PROJ. MANAGER	BY	DATE

KINGFIELD
 ROUTE 16\27
 CROSS SECTIONS

SHEET NUMBER
Xse
 OF 175

Date: \$date\$

Username:

Division: HIGHWAY

Filename: ... \Bentley\ustrn\Xsect.dgn

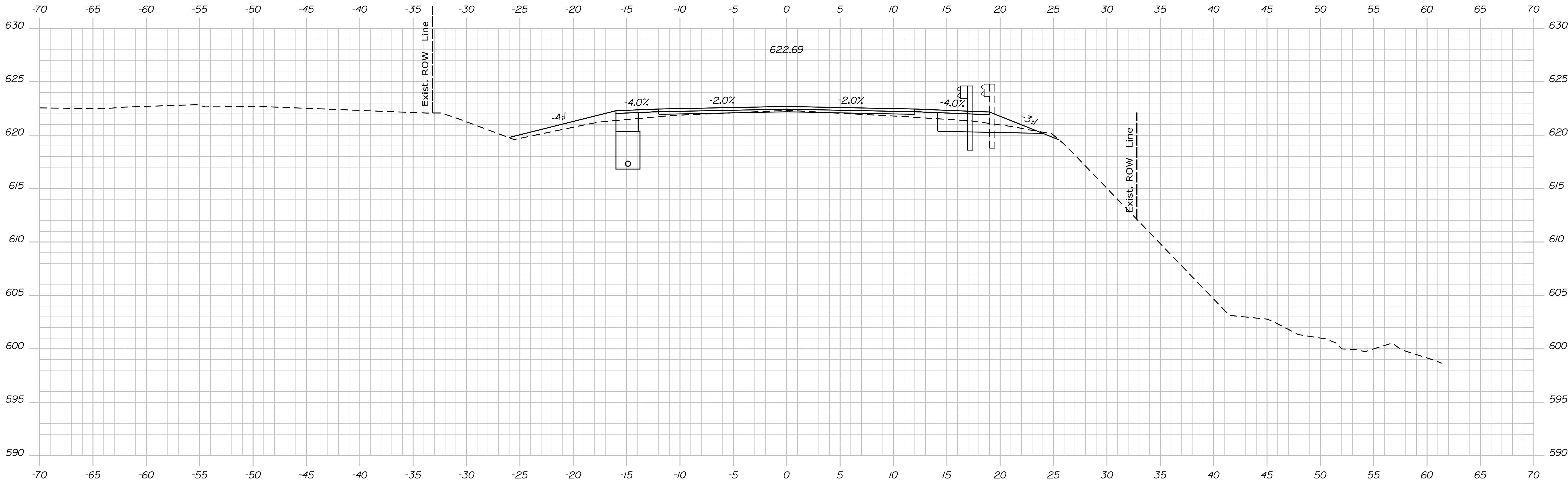

1127+00.00

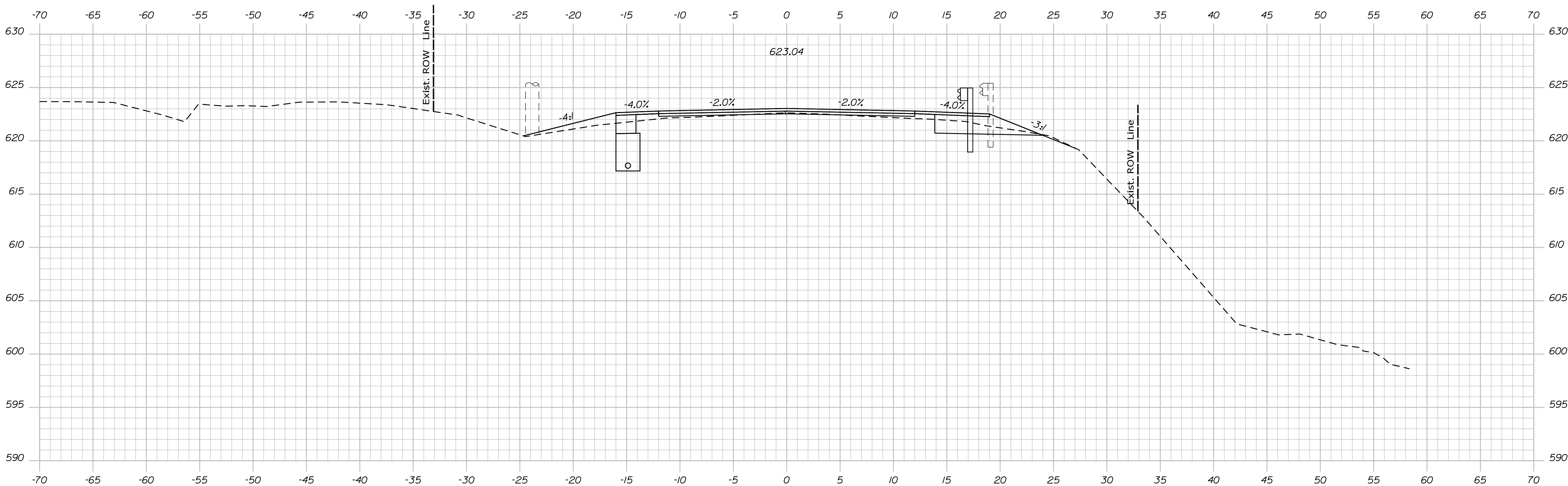

1126+50.00

STATE OF MAINE
DEPARTMENT OF TRANSPORTATION
STP-1824(500)
WIN
18245.00
HIGHWAY PLANS

SIGNATURE	DATE
P.E. NUMBER	DATE

PROJ. MANAGER	DATE
CHECKED/REVIEWED	
DESIGN DETAILER	
DESIGN DETAILER	
REVISIONS 1	
REVISIONS 2	
REVISIONS 3	
REVISIONS 4	
FIELD CHANGES	

KINGFIELD
ROUTE 16\27
CROSS SECTIONS

SHEET NUMBER
Xse
OF 175

Date: \$date\$

Username:

Division: HIGHWAY

Filename: ... \Bentley\ustrn\Xsect.dgn

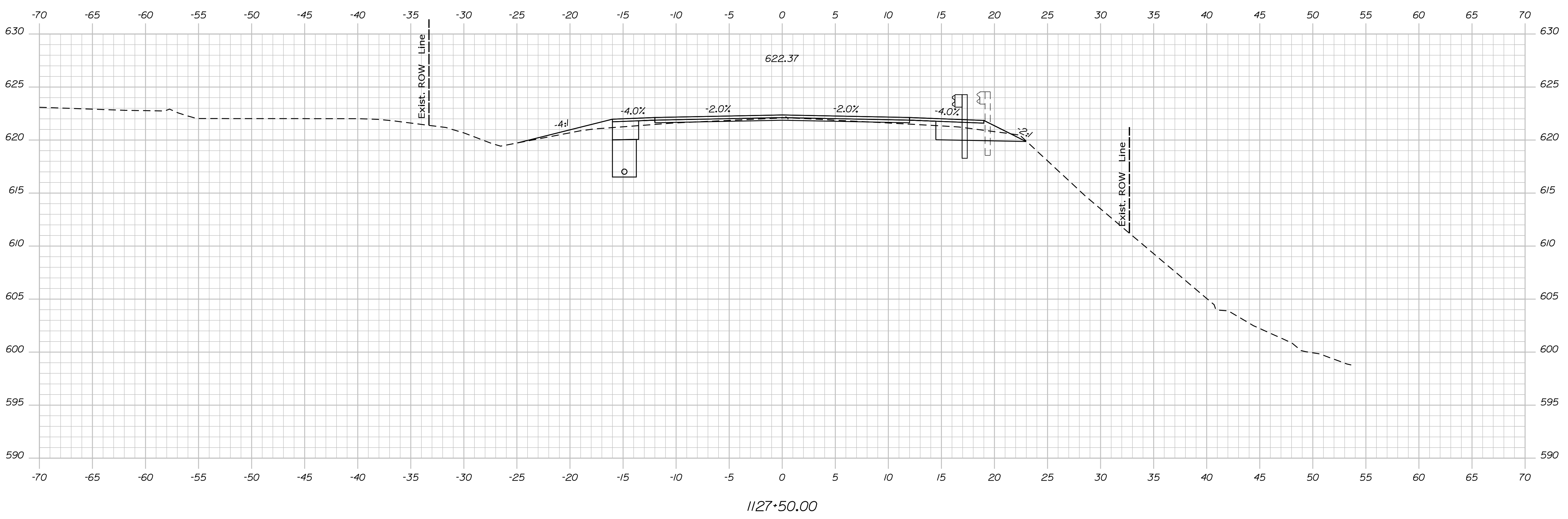
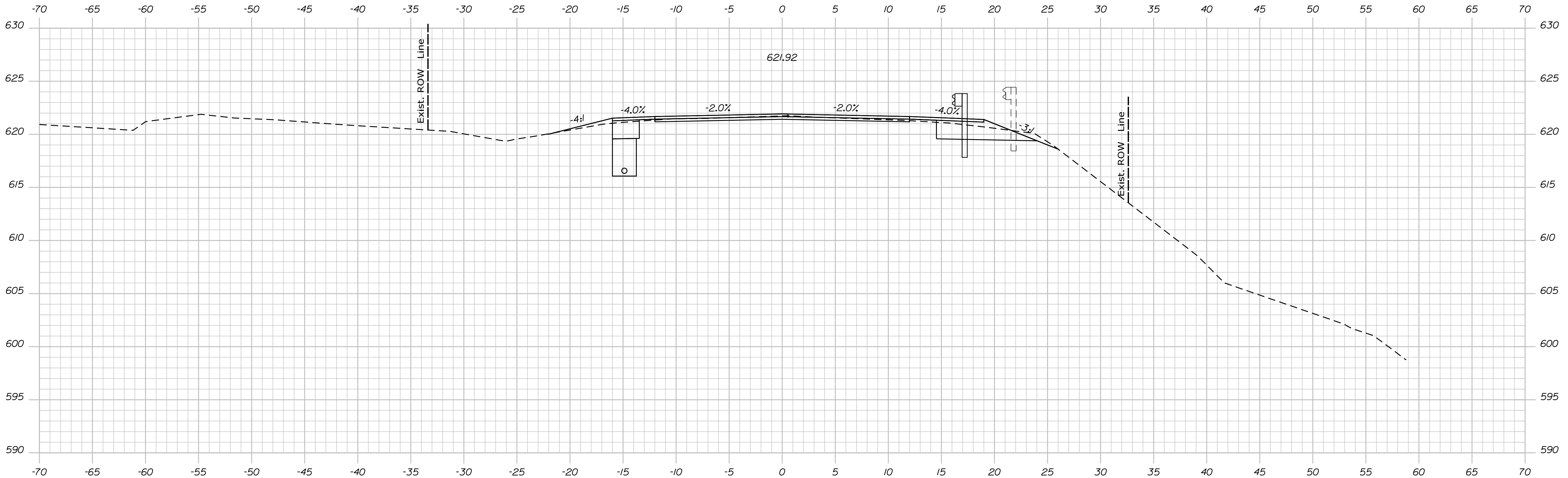

STATE OF MAINE
DEPARTMENT OF TRANSPORTATION
STP-1824(500)
WIN
18245.00
HIGHWAY PLANS

SIGNATURE
P.E. NUMBER
DATE

PROJ. MANAGER	DATE

KINGFIELD
ROUTE 16\27
CROSS SECTIONS

SHEET NUMBER
Xse
OF 175

Date: \$date\$

Username:

Division: HIGHWAY

Filename: ... \Bentley\ustrn\Xsect.dgn

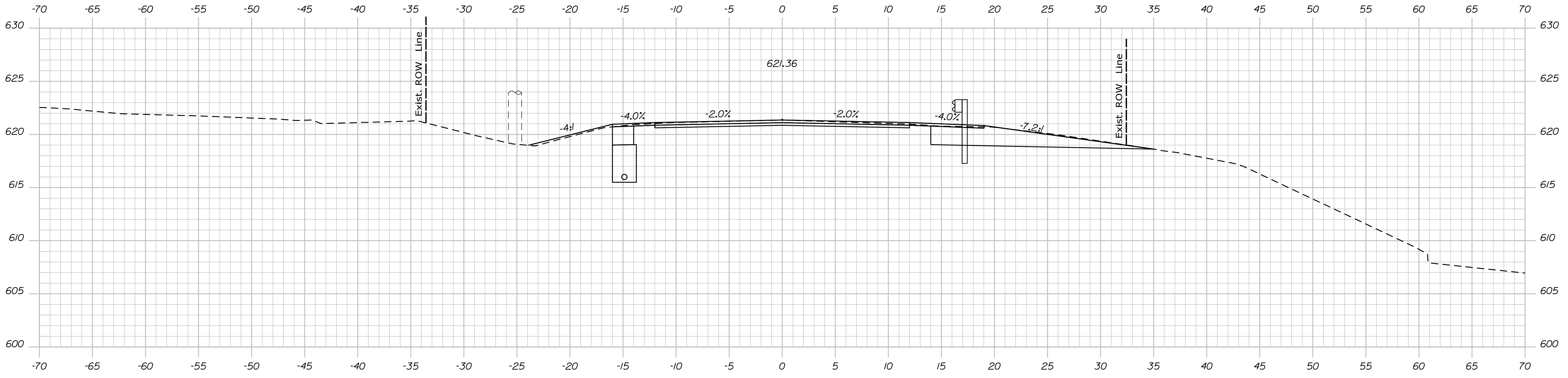

1129+00.00

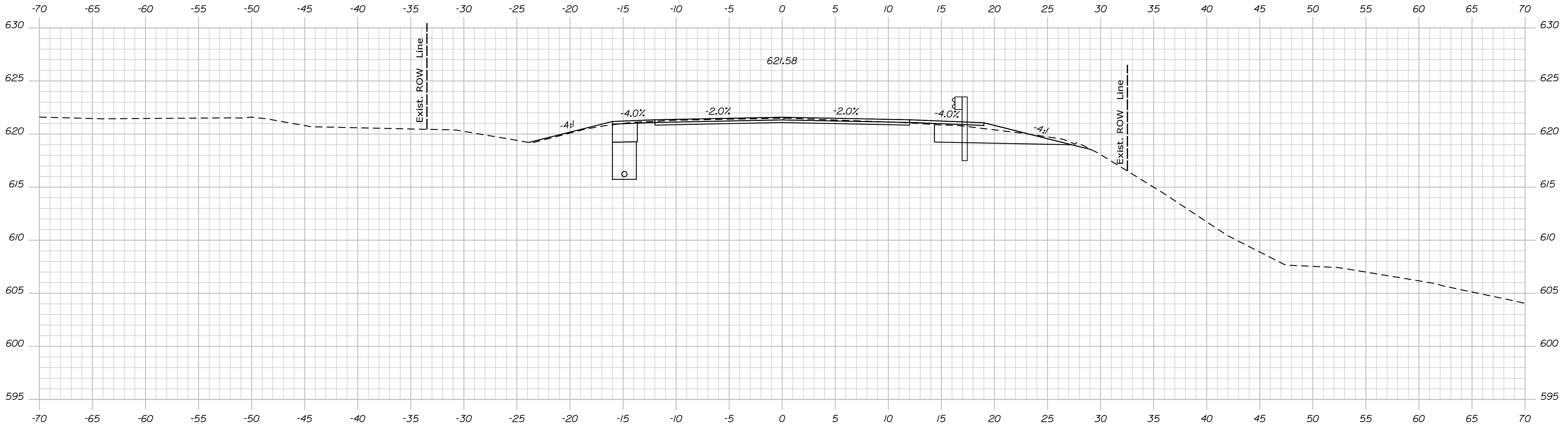

1128+50.00

STATE OF MAINE
 DEPARTMENT OF TRANSPORTATION
 STP-1824(500)
 WIN
 18245.00
 HIGHWAY PLANS

SIGNATURE
 P.E. NUMBER
 DATE

PROJ. MANAGER	DATE
DESIGN DETAIL	
CHECKED/REVIEWED	
DESIGN DETAIL	
DESIGN DETAIL	
REVISIONS 1	
REVISIONS 2	
REVISIONS 3	
REVISIONS 4	
FIELD CHANGES	

KINGFIELD
 ROUTE 16\27
 CROSS SECTIONS

SHEET NUMBER
Xse
 OF 175

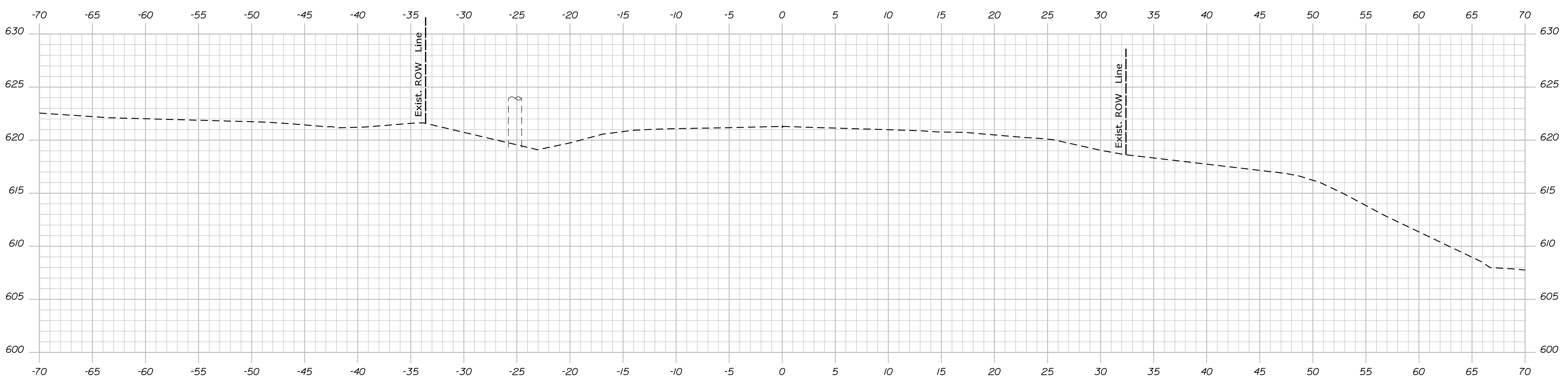

1129+17.01

STATE OF MAINE
 DEPARTMENT OF TRANSPORTATION
STP-1824(500)

WIN
 18245.00
 HIERARCHIC PLANS

PROJ. MANAGER	BY	DATE
DESIGN DETAILED		
CHECKED/REVIEWED		
DESIGN DETAILED		
DESIGN DETAILED		
REVISIONS 1		
REVISIONS 2		
REVISIONS 3		
REVISIONS 4		
FIELD CHANGES		

KINGFIELD
 ROUTE 16\27
 CROSS SECTIONS

SHEET NUMBER
Xse
 OF 175